



Bios

Bios International Corporation

10 Park Place
Butler, NJ, USA 07405

Phone: 973.492.8400
Toll Free: 800.663.4977
Fax: 973.492.8270

Email: sales@drycal.com
web: www.drycal.com

© 2007 Bios International Corporation
MK01-24 Rev A

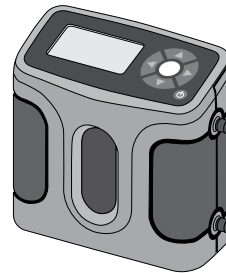

Defender 500 Series User Manual



Bios

Driving a Higher Standard
in Flow MeasurementSM

- ▣ Accuracy
- ▣ Reliability
- ▣ Convenience

Table of Contents

Introduction2

About Your Defender.....3

Operating Your Defender5

 Getting Started.....5

 Bios Optimizer Software.....7

Quick Start.....8

 Application Notes.....9

 Customizing Your Calibration10

 Setup10

 Measure12

 Out of Range!13

 Reset Function.....14

Annual Maintenance and Calibration14

 Recertification.....15

 Sending Your Defender to Bios.....16

 Shipping17

 Storage.....18

Defender 500 Series Specifications19

Limited Warranty.....21

For your convenience, your Defender manual has been printed on synthetic paper and is both tear proof and water resistant.

Introduction

Congratulations! You've chosen the Defender 500 Series primary gas flow calibrator, featuring proven DryCal® technology. Both the Defender 510 and Defender 520 models offer you $\pm 1\%$ of reading volumetric accuracy within a portable, rugged design engineered for the field calibration of air sampling pumps.

Before you get started, we recommend taking a few moments to review this manual and familiarize yourself with your Defender. If at any time you have questions regarding its operation, please contact Bios through our Web site (www.biosint.com) or call 973.492.8400 to speak with one of our knowledgeable customer support representatives.

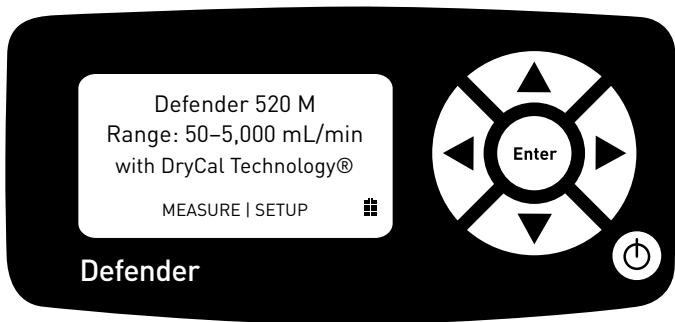

About Your Defender

The Defender is a true primary standard that provides instant indication of volumetric flow rate, within an accuracy of $\pm 1\%$ of reading. Its precision and high-speed operation make it an excellent tool for quickly and accurately setting the flow rate on air sampling pumps, in either suction or pressure applications.

The Defender 520 model goes a step further and uses integrated temperature sensors and pressure transducers in the flow stream to record the ambient conditions of the calibration process. An ideal "three-in-one" calibrator, the Defender 520 provides an enhanced audit trail – volumetric flow, temperature and pressure – without the need for additional instrumentation.

The Defender is powered by an internal lead-acid battery (included), which does not exhibit memory effect and may be charged continuously, even while the unit is in use.

The Defender features an On/Off control button, an LCD display screen and convenient touch pad control. Navigation through the various command screens is controlled by the right, left, up and down arrows on the touch pad.

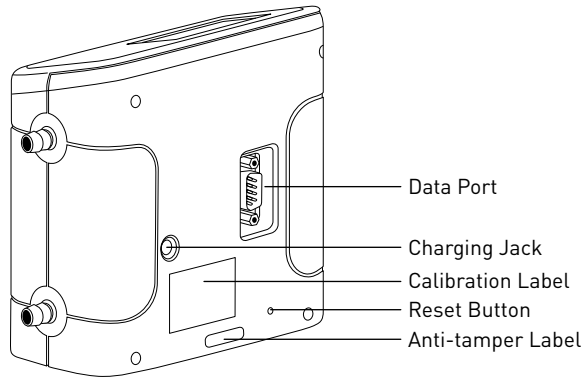
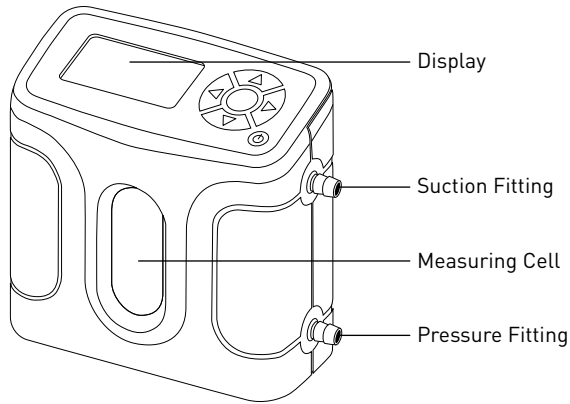

Your Defender comes with the following:

- AC Power Adapter/Charger
- Bios Optimizer Software CD
- PC Serial Cable
- Plastic Leak Test Caps (2); save for use during the Leak Test
- Calibration Certificate
- Manual

A soft-sided carry case or a hard Pelican case is available for purchase from Bios or your Bios distributor.

Operating Your Defender

Getting Started

Although the Defender's battery comes charged from the factory, we recommend fully charging your new battery by connecting the AC power adapter/charger to the Defender's charging jack and then plugging it into a standard wall outlet. Initial charging should take approximately eight hours.

After initial charging, you may continue to charge your Defender indefinitely by leaving it connected to the power supply. Otherwise, make sure to fully charge your Defender at least once every three months to help maintain battery life.

To turn on your Defender, press the On/Off button in the lower right corner of the control panel for one second. To turn it off, press and hold the On/Off button for three seconds.

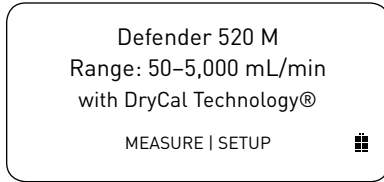

When turned on, your Defender displays a “splash” screen indicating the product name, model number and flow range. The Defender’s integrated battery indicator keeps you apprised of the instrument’s battery level. A full charge is indicated by a shaded battery icon. As the battery voltage drops the indicator will empty in 20% increments until an empty battery is displayed.

Navigating through your Defender’s menu screens is easy and intuitive. Simply press one of the four arrows on the control panel in the desired direction to toggle between menu options: the right arrow advances you forward, the left moves you backward, up moves you upward and down moves you downward.

Your location within each menu is highlighted in reverse type. A menu item in angle brackets (i.e., <...>) indicates that multiple options exist for that item. These options will be displayed if that item is selected.

To select an item that’s highlighted, press ENTER at the center of the navigational display on the control panel.

When you’re ready, visit SETUP and take some time to explore your Defender’s many user-definable settings, such as flow units; single or continuous measurements; choice of display size (520 model only); and date and time settings. Additionally, you can choose the number of measurements in the flow average and the time between measurements, options particularly useful for checking air sampling pump performance over a typical sampling period in order to verify that the pump is operating within the manufacturer’s stated specifications over a typical run cycle.

Bios Optimizer Software

Your Defender comes standard with Bios Optimizer 110 software that enables real time download of calibration data to a PC. Using Bios Optimizer 110 is easy and doesn’t require settings changes to your Defender. Once Optimizer is installed, simply connect your Defender’s data port to your PC’s RS-232 (serial) port using your Defender’s RS-232 cable and start taking measurements.

While taking measurements your PC’s screen will display real-time calibration data, a running average and a graphical representation of the flow readings. With the Defender 520 model, ambient temperature and pressure conditions are also displayed. Click Start to begin recording and your calibration data is automatically saved to a text file, with the file’s location in your PC displayed on the Bios Optimizer 110 home page.

The text file data can then be opened by a program such as Excel, where you can customize it as necessary.

For the ultimate audit trail, an upgrade to Bios Optimizer 120 is available. Bios Optimizer 120 software provides a comprehensive calibration database, complete with air sampling pump profiles (including pump models and serial numbers), employee information, searchable records and the ability to print personalized calibration certificates for your air sampling pumps. For more information about what the Bios Optimizer 120 upgrade can do for your audit trail, please contact Bios or your Bios distributor.

If you don't have an available serial port, you can purchase our approved PC card serial port adapter. Please note that Bios doesn't recommend or support the use of USB-to-serial port adapters due to known support issues with virtual serial ports.

Refer to www.biosint.com for information regarding any available firmware or Bios Optimizer software updates.

Quick Start

The Defender is designed to make the calibration of air sampling pumps easy and quick:

1. Connect the pump's tubing to the appropriate Defender port – either Suction (gas out) or Pressure (gas in), depending on your application – with your filter or sorbent tube between your Defender and the pump. For example, if using an air

sampling pump to draw air through a filter or sorbent tube, connect the pump's tubing to your Defender's upper barbed fitting (the Suction port). Or, if filling sample bags for the collection of gases and vapors, attach the pump's tubing to your Defender's lower barbed fitting (the Pressure port).

2. The splash screen defaults to MEASURE; press ENTER.
3. Select Single and press ENTER. A single measurement is initiated. Repeat this process to continue taking manual measurements one at a time or, switch to Continuous for a continuous uninterrupted stream of measurements.
4. Detach the pump's tubing from your Defender when done setting its flow rate. Your sampling pump is now calibrated and ready to begin sampling.

Application Notes

When taking measurements, your Defender displays the actual flow rate generated by the air sampling pump. Individual measurements, the running average of all measurements and the number of measurements in the average are provided simultaneously. Calibrate the pump by increasing or decreasing the pump's flow until the display reads your desired flow rate.

Customizing Your Calibration

Calibration of air sampling pumps can be customized and automated for your convenience. To customize each option, move between selections using the up and down arrows. When a selection is highlighted, use the right and left arrows to toggle between your choices for that selection. Press CONFIRM to save any changes and return to SETUP, or press EXIT to return to SETUP without saving any changes.

Setup

From the splash screen, choose SETUP to access the following customizable options:

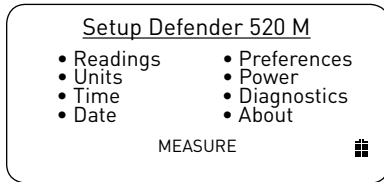

- **READINGS.** Choose your preferred number of measurements in the average, from 1 to 100. If you wish to measure in time intervals, set the time between measurements from 1 to 60 minutes.
- **UNITS.** View flow measurements in cubic centimeters, milliliters, liters or cubic feet (all units are per minute). In the Defender 520 model, view pressure in mmHg, kPa or PSI and temperature in Celsius or Fahrenheit.
- **TIME.** Set the current time in the format you prefer.

- **DATE.** Set the month/date/year in the format you prefer.
- **PREFERENCES.** Read Default offers a choice of Single, Continuous or Burst measurements; choose the type of flow measurement you will normally use. Once selected, your Defender will always default to this setting when Measure is selected. Return your Defender to its factory default settings by choosing Yes. In the Defender 520 model, Magnification controls the amount of data on the display; choose Zoom to view only flow measurements in larger font, or choose Detail to view flow measurements, temperature and pressure conditions in smaller font.
- **POWER.** Power Save defaults to On, which enables a five minute auto shut-off feature that turns your Defender off after five minutes of inactivity (unless plugged into AC power). Change the default to No if you want your Defender to remain on until you manually turn it off. Backlight allows you to turn the LCD backlight on for illumination or off to conserve battery power. Note: Setting Power Save to off when the Defender 220 is not connected to the adapter/charger will use all available battery power.
- **DIAGNOSTICS.** Gives you access to the integrated Leak Test function. To run the integrated Leak Test follow the on-screen prompts. Please note, the Defender Leak Test is designed only to verify the internal integrity of the instrument and alert you to an internal leak. We recommend performing the Leak Test only as an intermediate quality control check or whenever the integrity of the instrument is questioned due to accidental misuse or inadvertent damage.

Please keep in mind that the Leak Test is not a substitute for a comprehensive examination of the unit's overall performance, and a successful Leak Test does not ensure that your Defender is operating accurately. For this purpose, Bios offers recertification, our full-service package (see Recertification).

- **ABOUT.** Tells you more about your Defender; a useful screen to refer to when speaking with a Bios technical support representative or your Bios distributor.

If at any time you'd like to return your Defender to its factory default settings, navigate to Preferences, set Default Settings to Yes and then Confirm the changes.

Measure

Once you've finished customizing your Defender's SETUP and have confirmed your changes, select MEASURE from the SETUP screen (or from the splash screen if you have not been to SETUP). MEASURE gives you access to TAKE MEASUREMENTS, where you can choose between the following flow measurement options:

- **Single.** A manual measurement with a running average (default is 10 measurements in the average and is user-definable from 1 to 100).
- **Cont.** Continuous hands-free measurements with an on-screen running average (default is 10 measurements in the average and is user-definable from 1 to 100).

- **Burst.** A stream of hands-free measurements taken in a user-definable grouping of 1 to 100 measurements. Once completed, no more measurements are taken until another Burst is initiated.

Select the type of flow measurement you want, then press ENTER. The flow cell viewing window lights up, and the Defender instantly begins taking flow measurements.

You can stop a series of hands-free measurements at any time by choosing either PAUSE or RESET. PAUSE terminates the flow measurement or sequence of flow measurements but leaves the flow results on the screen, while RESET terminates the flow measurement or sequence of flow measurements and clears the screen, allowing a new sequence of measurements to begin.

EXIT returns you to the TAKE MEASUREMENTS screen, and SETUP allows you to further customize your Defender's operation.

Out of Range!

If your sampling pump is generating more flow than your Defender's rated flow range, the "Out of Range!" warning appears when you attempt to take a flow measurement. Immediately lower or disconnect the pump's flow. When the flow is within the proper range, choose RESET to clear your Defender's last measurement, or try to take a new measurement. You may verify your Defender's flow range by navigating to SETUP, then About.

Reset Function

If your Defender fails to respond to push-button commands, try resetting the unit by pressing the reset button on the back. This can be done easily with a bent paper clip. Please note that resetting your Defender will not affect your user settings. However, if you are in the middle of a calibration, your Defender will return to the initial measurement phase and you'll need to initiate a new flow measurement.

Annual Maintenance and Calibration

Your Defender is engineered to provide years of reliable service, with appropriate care and maintenance. Bios recommends annual calibration by an ISO 17025-accredited laboratory, such as Bios, to help ensure the best possible flow measurements, meet regulatory requirements and provide a bulletproof audit trail in the event of litigation. If you should encounter any problems with your Defender, immediately contact Bios Customer Service and provide a detailed description of your situation, including the Defender model and serial number, information about the air sampling pump and the current sample train, the environmental conditions during the test, the flow point or points that you're checking and a detailed explanation of the issue you're experiencing.

Recertification

Your Defender is a precision measuring standard with moving parts machined to extremely close tolerances. Various environmental factors, product wear, drift of the temperature sensors and pressure transducers used for recording ambient calibration conditions (Defender 520), or inadvertent damage may adversely affect your Defender's measurement accuracy or general performance.

For these reasons, Bios highly recommends having your Defender annually verified by an ISO 17025-accredited laboratory, such as Bios, to ensure its measurement integrity. For those applications subject to regulatory or ISO requirements, verification by a laboratory accredited to the international calibration standards set by ISO provides you with assurance of measurement integrity and a defensible audit trail in the event of litigation.

For the ultimate in Defender maintenance and to take advantage of any available software and mechanical upgrades, Bios offers an elective Recertification program. This is a complete product service package that provides pre-calibration; complete product refurbishment, testing and available upgrades; post-calibration; and NIST-traceable, ISO 17025-, ANSI Z-540- and NIST Handbook 150-backed calibration certificates. Recertification includes a 90-day service warranty should any related labor or parts replacements prove faulty.

Turnaround time is generally two weeks from time of receipt. For an expedite fee, we will place your Defender "next on bench" for 48-hour turnaround. This means that a Defender received on

Monday will be return-shipped on Wednesday, and a Defender received on Friday will be return-shipped on Tuesday. For a detailed explanation of the 48 hour process and to obtain current pricing for recertification, please contact Bios at 973.492.8400 or visit our web site at www.biosint.com.

Please note that while any ISO 17025–accredited gas flow measurement laboratory may be capable of verifying the accuracy of your Defender, Bios is the only authorized service center for Bios products. All Defender service and calibration is performed in our ISO 17025–accredited laboratory in New Jersey by experienced Bios personnel.

Sending Your Defender to Bios

Please contact Bios for an RMA (return merchandise authorization) number before sending your Defender to our factory for elective Recertification or other service. You can get an RMA number through our automated web-based system at www.drycal.com/forms/rma.htm, by email to service@biosint.com, or by telephone at 973.492.8400. Our web site address is www.biosint.com.

Sending your Defender to Bios without an RMA number may result in return of the instrument without inspection or a substantial delay in service turnaround time.

When requesting an RMA number, provide your Defender model, serial number and revision level. Also describe any product issues you may be experiencing. Please keep in mind that Bios will not begin evaluation and service of your Defender until you have accepted and approved, in writing, our formal RMA quote for

service. This protects both you and Bios during this process and ensures a fair and efficient service experience.

If sending your Defender for repair or evaluation (rather than elective Recertification), please contact Bios for technical support or troubleshooting assistance prior to shipping the unit. We will first attempt to resolve the situation over the phone or via email. If you've provided us with a detailed description of your Defender's issue and application details and we're unable to resolve the situation by phone or email, we'll issue you an RMA number for prompt return of your Defender for evaluation.

Please note that Bios will make every attempt to verify your issue, as we want you to get the most out of your Defender. However, if we are unable to detect a product issue or if we determine that the issue is application-related rather than product-related, we reserve the right to charge an evaluation fee.

Shipping

When shipping your Defender, please ensure that the packaging is adequate to protect the instrument. Whenever possible, your Defender should be shipped in its original packaging or within a hard case such as a Pelican carrying case (available for purchase from Bios). We highly recommend using a standard freight carrier (e.g., FedEx, UPS) that supplies tracking numbers and insuring the product against damage in transit.

Bios is generally not responsible for freight costs associated with shipments to and from Bios, except in certain instances; please contact Bios for information before initiating a shipment.

Bios is not responsible for damage that may occur during shipment.

Storage

If you need to store your Defender for an extended period, please follow these guidelines:

- Always store it in a clean, dry place.
- If possible, leave it attached to its AC power adapter/charger while in storage.
- If your Defender cannot be attached to its AC power adapter/charger while in storage:
 - Fully charge it before extended storage. If the battery isn't fully charged prior to storage, it might be permanently damaged.
 - Fully charge it at least once every three months.
- When removing your Defender from storage, recharge the battery for at least 12 hours prior to use.

Defender 500 Series Specifications

Models:

510L/520L, from 5-500 mL/min

510M/520M, from 50-5,000 mL/min

510H/520H, from 300-30,000 mL/min

Measurements:

Volumetric Accuracy: $\pm 1\%$ of reading

Time per Measurement: 1-15 seconds (approximate)

Type: Single, Continuous or Burst

Volumetric Flow Units: cc/min, mL/min, L/min, cf/min

Pressure Units (Defender 520): mmHg, PSI, kPa

Temperature Units (Defender 520): degC, degF

Basics:

Dimensions (H x W x D): 5.5 x 6 x 3 in / 140 x 150 x 75 mm

Weight: 29 oz / 820 g

Configuration: Integrated flow measuring cell, valve and timing mechanism

Temperature & Pressure Sensors (Defender 520 model only):

In the flow stream

Press.: 3.5 mmHg (typical), 7.0 mm (max);

Temp.: 0.8 deg C (typical), 1.3 deg C (max)

AC Adapter/Charger: 12V DC, >250ma, 2.5 mm, center positive

Battery: 6V rechargeable, sealed lead-acid, 6-8 hours typical operation

Battery Operational Time (5 cycles/min):

3 hrs backlight on, 8 hrs backlight off

Pressure & Suction Fittings: ¼" barbed tube fittings

Display: Backlit graphical LCD

Usage:

Flow Modes: Suction or Pressure

Operating Pressure (Absolute): 15 PSI

Ambient Humidity: 0–70%, non-condensing

Storage Temperature: 0–70 °C

Warranty: 1 year; battery 6 months

Bios Optimizer Software

Requires Windows XP–SP2 or Windows 2000–SP3 compatible PC and RS-232 (serial) connection

Bios Optimizer 110 installation CD (supplied); no restrictions apply

RS-232 cable (supplied) for Defender 500 Series data port to PC RS-232 (serial) port connection

PC Card (optional and as necessary) creates an RS-232 port on your PC

Licensed upgrade to Bios Optimizer 120 is available

Limited Warranty

The Bios DryCal Defender 500 Series is warranted to the original end user to be free from defects in materials and workmanship under normal use and service for a period of one year from the date of purchase as shown on the purchaser's receipt. The Defender 500 Series' battery is warranted for six months from the original purchase date. If the unit was purchased from an authorized reseller, a copy of an invoice or packing slip showing the date of purchase may be required to obtain warranty service.

The obligation of Bios International Corporation under this warranty shall be limited to repair or replacement (at our option), during the warranty period, of any part that proves defective in material or workmanship under normal use and service, provided the product is returned to Bios International Corporation, transportation charges prepaid.

Notwithstanding the foregoing, Bios International Corporation shall have no liability to repair or replace any Bios International Corporation product:

1. That has been damaged following sale, including but not limited to damage resulting from improper electrical voltages or currents, defacement, misuse, abuse, neglect, accident, fire, flood, terrorism, act of God or use in violation of the instructions furnished by Bios International Corporation;
2. When the serial number has been altered or removed; or
3. That has been repaired, altered or maintained by any person or party other than Bios International Corporation's own service facility or a Bios authorized service center, should one be established.

This warranty is in lieu of all other warranties and all other obligations or liabilities arising as a result of any defect or deficiency of the product, whether in contract or in tort or otherwise. All other warranties, expressed or implied, including any implied warranties of merchantability and fitness for a particular purpose, are specifically excluded.

In no event shall Bios be liable for any special, incidental or consequential damages for breach of this or any other warranty, express or implied, whatsoever.