



GEMINI[®]

Twin Port Sampler

Operation Manual

WARNING

THIS MANUAL MUST BE CAREFULLY READ BY ALL INDIVIDUALS WHO HAVE OR WILL HAVE THE RESPONSIBILITY FOR USING OR SERVICING THE PRODUCT. Like any piece of complex equipment, the instrument will perform as designed only if it is used and serviced in accordance with the manufacturer's instructions. OTHERWISE, IT COULD FAIL TO PERFORM AS DESIGNED AND PERSONS WHO RELY ON THIS PRODUCT FOR THEIR SAFETY COULD SUSTAIN SEVERE PERSONAL INJURY OR DEATH.

The warranties made by Mine Safety Appliances Company with respect to the product are voided if the product is not used and serviced in accordance with the instructions in this manual. Please protect yourself and others by following them. We encourage our customers to write or call regarding this equipment prior to use or for any additional information relative to use or repairs.

In the U.S., to contact your nearest stocking location, dial toll-free 1-800-MSA-2222. To contact MSA International, dial 1-412-967-3354.

© Mine Safety Appliances Company 1999
All Rights Reserved

Manufactured by

MINE SAFETY APPLIANCES COMPANY
P.O. Box 427, PITTSBURGH, PENNSYLVANIA 15230

Table of Contents

Chapter 1, Basic Operation	1-1
Introduction	1-1
Description	1-1
Contents of Kit	1-1
Figure 1-1. Worker Wearing GEMINI Twin-Port Sampler	1-2
Figure 1-2. Worker Wearing 2 Samplers with "Y" Connection	1-3
Operation Instructions	1-4
Figure 1-3. GEMINI Twin-Port Sampler Kit	1-4
Figure 1-4. Inserting Sorbent Tubes into the GEMINI Sampler	1-5
Figure 1-5. Setting the Flow Rate with the Optiflow Calibrator	1-6
Helpful Hints	1-7
Remote Sampling	1-8
Area Sampling	1-8
Figure 1-6. Quiet Flow Pump with Multiple GEMINI Samplers for Area Sampling	1-9
Chapter 2, Maintenance	2-1
Tube Holder	2-1
Foam Filter	2-1
Filter Disc	2-1
Valves	2-2
Performance Test	2-2
Chapter 3, Parts List	3-1

Chapter 1

Basic Operation

Introduction

Congratulations on your purchase of the GEMINI Twin-Port Sampler, an instrument designed for low flow industrial hygiene sampling and backed by years of MSA quality, dedication, and service.

Please read the "Operation Instructions" and "Helpful Hints" portions of this manual before using the Sampler.

Description

The GEMINI Sampler is designed to measure concentrations of gases and vapors when used with MSA or other manufacturer's Sorbent Tubes. It is compatible with any personal sampling pump capable of 1.5 LPM flow rate at a load of 25" of water column (w.c.). See FIGURES 1-1 and 1-2.

Contents of Kit (See FIGURE 1-3)

- GEMINI Sampler with Tube Protector for small Sorbent Tubes
- Tube Protector for larger Sorbent Tubes
- Tubing (1/8" ID for connection to GEMINI Sampler, connected by a fitting to 1/4" ID)

- Four Clips (one for each Tube Protector and two extra for clipping to the bottom of the GEMINI Sampler and for tubing management)

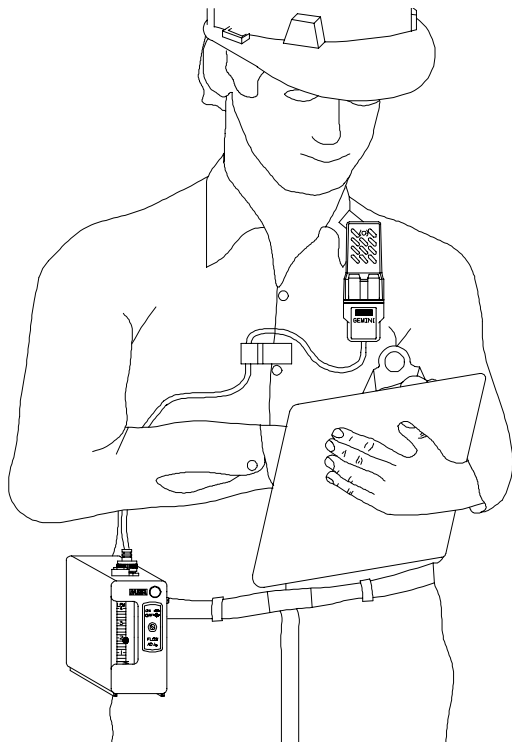

*Figure 1-1.
Worker Wearing GEMINI Twin-Port Sampler*

- "Y" Connector for multi-Sampler applications

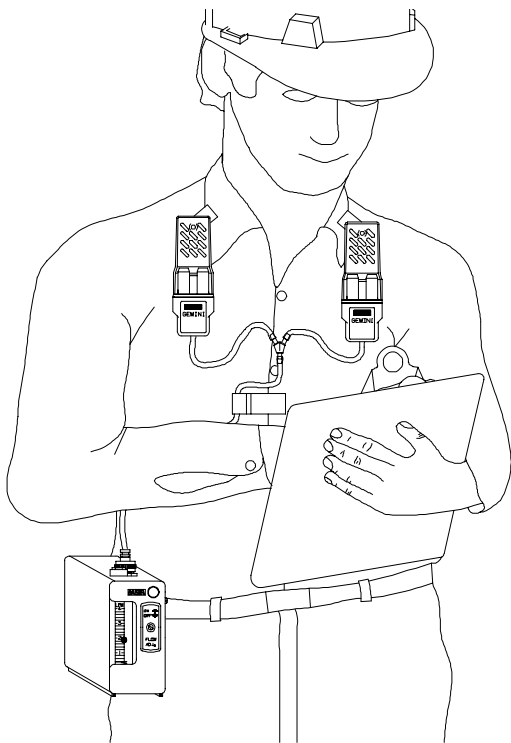

*Figure 1-2.
Worker Wearing two Samplers with a "Y" Connection*

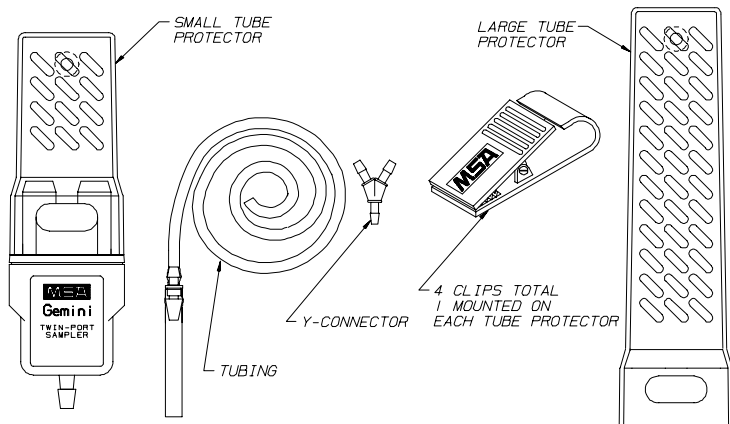
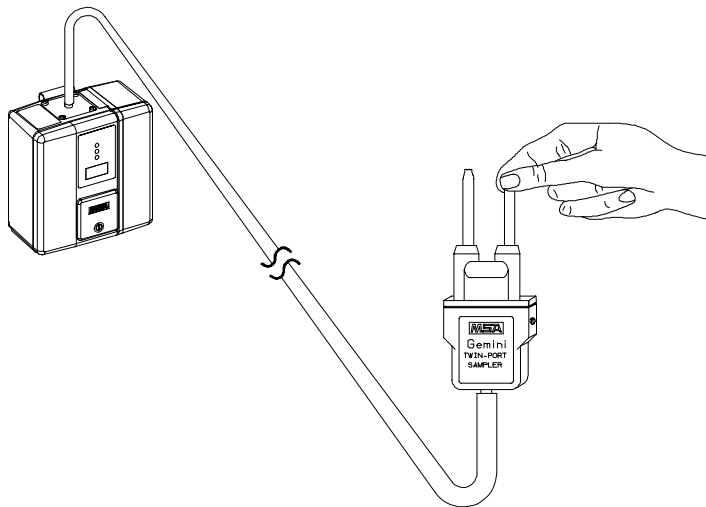

Figure 1-3.
GEMINI Twin-Port Sampler Kit

Operation Instructions

1. Connect the pump inlet to the GEMINI Sampler barb fitting using the tubing and the adapter supplied. (The adapter may not be needed for some pumps.)
2. Turn on the pump, and adjust the flow to approximately 1.5 LPM (1.2 to 1.7 LPM). As a general rule, the pump flow rate needs to be at least two to three times the total flow rate through the tubes.
3. Remove the Tube Protector from the GEMINI Sampler.

4. Break off both tips of the Tube to be used for sampling.
5. Install Tubes in the Tube Holders. See FIGURE 1-4.



*Figure 1-4.
Inserting Sorbent Tubes into the GEMINI Sampler*

6. Preset the flow rates through each Tube to the approximate flow desired (see "Helpful Hints" #3 later in this chapter).
7. Connect a length of tubing to the inlet of one Tube.
8. Connect the other end of this tubing to a primary calibrator or a precalibrated flowmeter.

- Flow rates may be easily set by using the MSA Model 655 OPTIFLOW™ Digital Flow Indicator (part no. 635477) or an equivalent device (FIGURE 1-5).
9. Adjust the needle valve to obtain the desired flow rate through the Tube.
 10. Repeat steps 6, 7, and 8 for the other Tube.
- NOTE:** The total flow must not exceed 500 ml per minute (ml/min.).
11. Install either the large or small Tube Protector.
 12. Sampling may begin immediately, or the pump may be turned off until sampling is to be started.

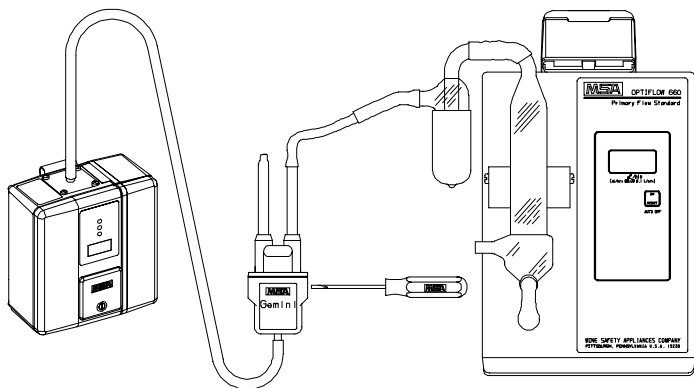

Figure 1-5.
Setting the Flow Rate with the Optiflow Calibrator

Helpful Hints

1. The needle valves have very fine threads and seats; do not force them closed. If no sample is to be taken through one side, simply turn the valve clockwise until resistance is felt; then, stop.
2. Do not attempt to operate the Sampler with needle valve settings beyond the point where the top of the slotted portion is flush with the brass valve body.
3. There is a very small interaction between the setting of the two flows. The flows can be most quickly and accurately set by:
 - Presetting both valves to the approximate flow desired:
 - 50 ml/min. = one turn counterclockwise
 - 200 ml/min. = two turns counterclockwise
 - 350 ml/min. = three turns counterclockwise
 - If samples are to be taken at two different flow rates, calibrate and fine adjust the higher flow rate tube position first.

If the total flow through both tubes is near the 500 ml/min. limit and difficulty is experienced, try increasing the pump setting to 1.7 LPM or use some other equipment to make sure the pump is actually delivering 1.5 LPM when loaded to 25" w.c.

4. When operating two Samplers from one pump, these hints are even more important. Presetting all four valves will make calibration easier. If all four tubes are set for high flows and the total flow is near the 500 ml/min. limit, make sure the pump is drawing 1.5 LPM. If some additional care is taken when calibrating and fine adjusting,

the total flow for four tubes may be up to 1000 ml/min., with a maximum of 500 ml/min. through each GEMINI Sampler if the pump flow rate is adjusted nearer to 1.7 LPM. Keep in mind that this additional board will likely shorten the expected running time of the sampling pump.

5. While rotameters or other devices may be used for rough setting of flows, their inherent pressure drop adds to the tube load. Therefore, use only a soap film device, the Optiflow 655 (part no. 635477) for final flow calibration. Always have the actual tube or equivalent load in place during flow calibration.

Remote Sampling

Remote sampling can be accomplished by connecting a remote sampling line between the pump and the Sampler. The sampling line should have an inside diameter of 1/8-inch or larger to prevent loading the pump.

Area Sampling

Multiple point perimeter sampling can also be readily accomplished by using a higher capacity vacuum source with a low cost manifold and critical orifice system (see FIGURE 1-6). To use the critical orifice system, the vacuum source must be capable of maintaining at least 15 inches of mercury suction while pumping 1.5 lpm for each Sampler (15 lpm for ten Samplers).

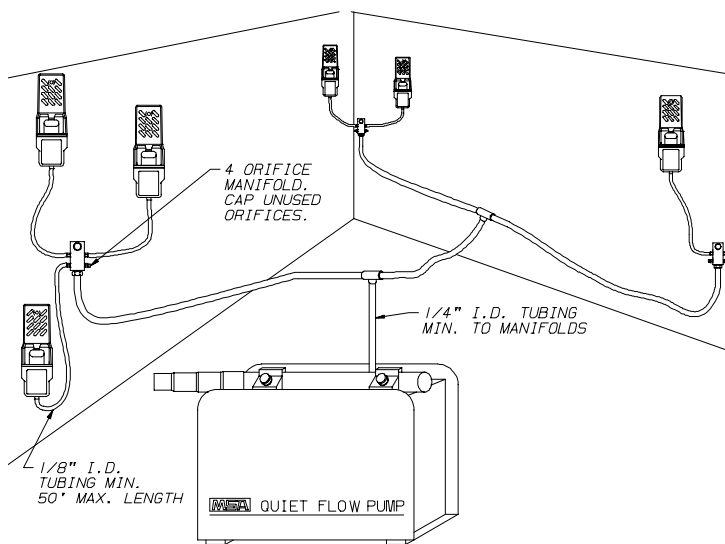

Figure 1-6. Quiet Flow Pump with Multiple GEMINI Samplers for Area Sampling

The pump used must be capable of pulling 15" Hg at outlet(s) of manifold(s) at a total flow of 1.5 LPM for each Sampler. (In this example, six GEMINI Samplers require a pump that can handle 9 LPM total flow.) Set the pump flow to give a vacuum of 15" Hg or greater. Actual flow will be slightly less than 1.5 LPM per GEMINI Sampler when using the MSA-supplied critical orifice manifold assembly.

Chapter 2

Maintenance

Under conditions of normal use, this Sampler should require little maintenance. Depending on the frequency of use, periodic cleaning and checks for correct performance are recommended.

Tube Holder

Replace the Tube Holder when it shows signs of wear or damage. If filter is not clogged or cracked, it may be used in the new Tube Holder if it is inserted so the flow through it is in the same direction. The stainless steel washer must be placed on the Holder before reinstalling the pressure plate. To remove the tube holder or to change the filter in the tube holder, remove the four phillips head screws located on the green pressure plate.

Foam Filter

The round black foam filter on the back of the GEMINI Sampler prevents dust from entering the unit. This filter can be easily removed, cleaned and replaced or replaced by a new foam filter. Ten extra foam filters (P/N 497715) are supplied with the unit.

Filter Disc

Periodically remove the Filter Disc for cleaning or replacement.

1. Remove the Filter Disc from the Tube Holder by rolling the flange part of the Tube Holder down and away from the Disc.
2. Gently tap or blow on the surface to remove any foreign matter.
3. Replace the Disc, orienting it so the previously exposed surface is once again facing away from the Sampler.

Valves

The needle valve stem of each valve can be occasionally removed for inspection of the needle and the needle seat.

1. Turn the stem counterclockwise until it is free of the valve body.
2. Clean the needle by wiping it with a soft tissue.
3. If the valve seems to be clogged (i.e., you are unable to achieve 500 ml/min. flow at 3-1/2 to 4 turns open), remove the pressure plate and Tube Holders. Direct a stream of compressed air through the open valve body to help dislodge any particulate matter causing the problem.
4. Reinstall the needle.

Performance Test

After extended idleness and periodically during use, check the Sampler for proper performance with the following test:

1. Connect a water manometer or vacuum gauge to one of the Tube Holders.
2. Open the associated needle valve 3 to 4 turns counterclockwise from fully closed.
3. Connect a flowmeter to the other Tube Holder.
4. Close (fully clockwise position) the associated needle valve.

NOTE: The vacuum setting should read between 18" and 26" w.c.; the flow should read less than 2 ml/min.

5. Open the needle valve to adjust the flow to achieve 250 to 300 ml/min.

NOTE: The vacuum setting should remain within 2" w.c. of the reading noted after step 4.

Chapter 3

Parts List

NO. IN REPAIR KIT	PART	PART NO.
1	Sample Tube Pressure Plate	497711
	Large Tube Protector	497712
	Small Tube Protector	800103
2	Clip Assembly	800296
	Instruction Manual	800302
	Filter Label	800095
1	Foam Filter, Sheet of 10	497715
2	Tube Holder, 2 required	463801
2	Filter Disc, 2 required	463799
2	Stainless Steel Washer, 2 required	634257
	1/4 I.D. Clear Vinyl Tubing	027234
	1/8 I.D. Clear Silicone Tubing, 3 feet required	602294
	Black Nylon Connector	636477
	"Y" Fitting	636563
4	Screw, 4 required	636267
	Optiflow #655 Calibrator	635477
	Repair Kit of Parts for Gemini Sampler	802208
	Manifold Assembly, 4 Station	802446