

Continuous Gas Analyzer, extractive

OXYMAT 6

General information

Overview



The function of the OXYMAT 6 gas analyzers is based on the paramagnetic alternating pressure method and are used to measure oxygen in gases.

Benefits

- Paramagnetic alternating pressure principle
 - Small measuring ranges (0 to 0.5 % or 99.5 to 100 % O₂)
 - Absolute linearity
- Detector element has no contact with the sample gas
 - Can be used under harsh conditions
 - Long service life
- Physically suppressed zero through suitable selection of reference gas (air or O₂), e.g. 98 to 100 % O₂ for purity monitoring/air separation
- Open interface architecture (RS 485, RS 232, PROFIBUS)
- SIPROM GA network for maintenance and service information (option)
- Electronics and physics: gas-tight isolation, purging is possible, IP65, long service life even in harsh environments (field device only)
- Heated versions (option), use also in presence of gases condensing at low temperature (field device only)
- EEx(p) for zones 1 and 2 according to ATEX 2G and ATEX 3G (field device only)

Application

Fields of application

- For boiler control in incineration plants
- In safety-related areas
- In the automotive industry (testbed systems)
- Warning equipment
- In chemical plants
- For ultra-pure gas quality monitoring
- Environmental protection
- Quality monitoring
- Inert gas monitoring with certified gas warning equipment (DMT certificate)
- Versions for analyzing flammable and non-flammable gases or vapors for use in hazardous areas

Special versions

Special applications

Besides the standard combinations, special applications concerning material in the gas path, material in the sample cells are also available on request

TÜV version QAL

As a reference variable for emission measurements according to TA-Luft, 13th and 17th BImSchV

Design

19" rack unit

- With 4 HU for installation
 - in hinged frame
 - in cabinets with or without telescopic rails
- Front plate can be swung down for servicing purposes (laptop connection)
- Internal gas paths: hose made of FKM (Viton) or pipe made of titanium or stainless steel (mat. no. 1.4571)
- Gas connections for sample gas inlet and outlet and for reference gas: fittings, pipe diameter of 6 mm or ¼"
- Flow indicator for sample gas on front plate (option)
- Pressure switch in sample gas path for flow monitoring (option)

Field device

- Two-door enclosure with gas-tight separation of analyzer and electronics sections
- Each half of the enclosure can be purged separately
- Analyzer unit and piping can be heated up to 130 °C (option)
- Gas path and stubs made of stainless steel (mat. no. 1.4571) or titanium, Hastelloy C22
- Purging gas connections: pipe diameter 10 mm or 3/8"
- Gas connections for sample gas inlet and outlet and for reference gas: clamping ring connection for a pipe diameter of 6 mm or ¼"

Display and control panel

- Large LCD panel for simultaneous display of:
 - Measured value (digital and analog displays)
 - Status bar
 - Measuring ranges
- Contrast of LCD panel adjustable using menu
- Permanent LED backlighting
- Washable membrane keyboard with five softkeys
- Menu-driven operation for parameterization, test functions, adjustment
- User help in plain text
- Graphic display of concentration trend; programmable time intervals
- Bilingual operating software German/English, English/Spanish, French/English, Spanish/English, Italian/English

Continuous Gas Analyzer, extractive

OXYMAT 6

General information

Input and outputs

- One analog output per measured component (from 0, 2, 4 to 20 mA; NAMUR parameterizable)
- Two analog inputs configurable (e.g. correction of cross-interference, external pressure sensor)
- Six binary inputs freely configurable (e.g. for measurement range switchover, processing of external signals from sample preparation)
- Six relay outputs freely configurable (failure, maintenance request, maintenance switch, threshold alarm, external magnetic valves)
- Expansion: by eight additional binary inputs and eight additional relay outputs each, e.g. for autocalibration with up to four calibration gases

Communication

RS 485 present in the basic unit (connection at the rear; for the rack unit also behind the front plate).

Options

- AK interface for the automotive industry with extended functions
- RS 485/RS 232 converter
- RS 485/Ethernet converter
- RS 485/USB converter
- Connection to networks via PROFIBUS DP/PA interface
- SIPROM GA software as the service and maintenance tool

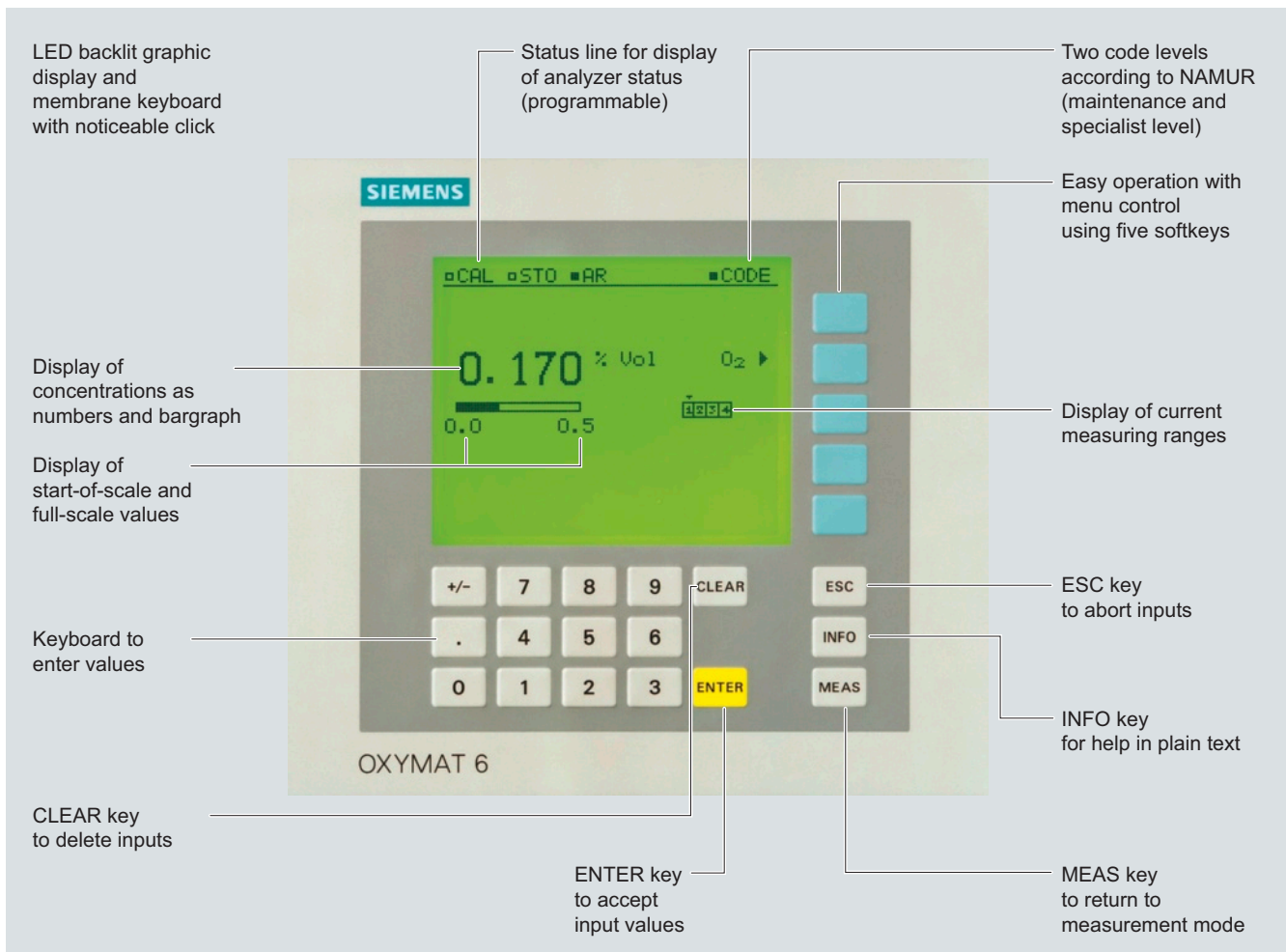

OXYMAT 6, membrane keyboard and graphic display

Continuous Gas Analyzer, extractive

OXYMAT 6

General information

Designs – Parts touched by sample gas, standard

Gas path		19" rack unit	Field device	Field device Ex
With hoses	Bushing	Stainless steel, mat. no. 1.4571	-	-
	Hose	FKM (e.g. Viton)		
	Sample chamber	Stainless steel, mat. no. 1.4571 or Tantalum		
	Fittings for sample chamber	Stainless steel, mat. no. 1.4571		
	Restrictor	PTFE (e.g. Teflon)		
	O-rings	FKM (e.g. Viton)		
With pipes	Bushing	Titanium		
	Pipe	Titanium		
	Sample chamber	Stainless steel, mat. no. 1.4571 or Tantalum		
	Restrictor	Titanium		
	O-rings	FKM (Viton) or FFKM (Kalrez)		
With pipes	Bushing	Stainless steel, mat. no. 1.4571		
	Pipe	Stainless steel, mat. no. 1.4571		
	Sample chamber	Stainless steel, mat. no. 1.4571 or tantalum		
	Restrictor	Stainless steel, mat. no. 1.4571		
	O-rings	FKM (Viton) or FFKM (Kalrez)		
With pipes	Bushing		Hastelloy C 22	
	Pipe		Hastelloy C 22	
	Sample chamber		Stainless steel, mat. no. 1.4571 or tantalum	
	Restrictor		Hastelloy C 22	
	O-rings		FKM (e.g. Viton) or FFKM (e.g. Kalrez)	

Options

Flow indicator	Measurement pipe	Duran glass	-	-
	Variable area	Duran glass, black		
	Suspension boundary	PTFE (Teflon)		
	Angle pieces	FKM (Viton)		
Pressure switch	Membrane	FKM (Viton)	-	-
	Enclosure	PA 6.3 T		

Gas path (19" rack unit)

Legend for the gas path figures

- | | | | |
|---|-----------------------------------|----|--|
| 1 | Sample gas inlet | 8 | Pressure switch in sample gas path (option) |
| 2 | Sample gas outlet | 9 | Purging gas |
| 3 | Not used | 10 | Pressure switch in reference gas path (option) |
| 4 | Reference gas inlet | 11 | Pressure sensor |
| 5 | Restrictor in reference gas inlet | 12 | Filter |
| 6 | O ₂ physical system | 13 | Flow indicator in sample gas path (option) |
| 7 | Restrictor in sample gas path | 14 | Outlet restrictor |

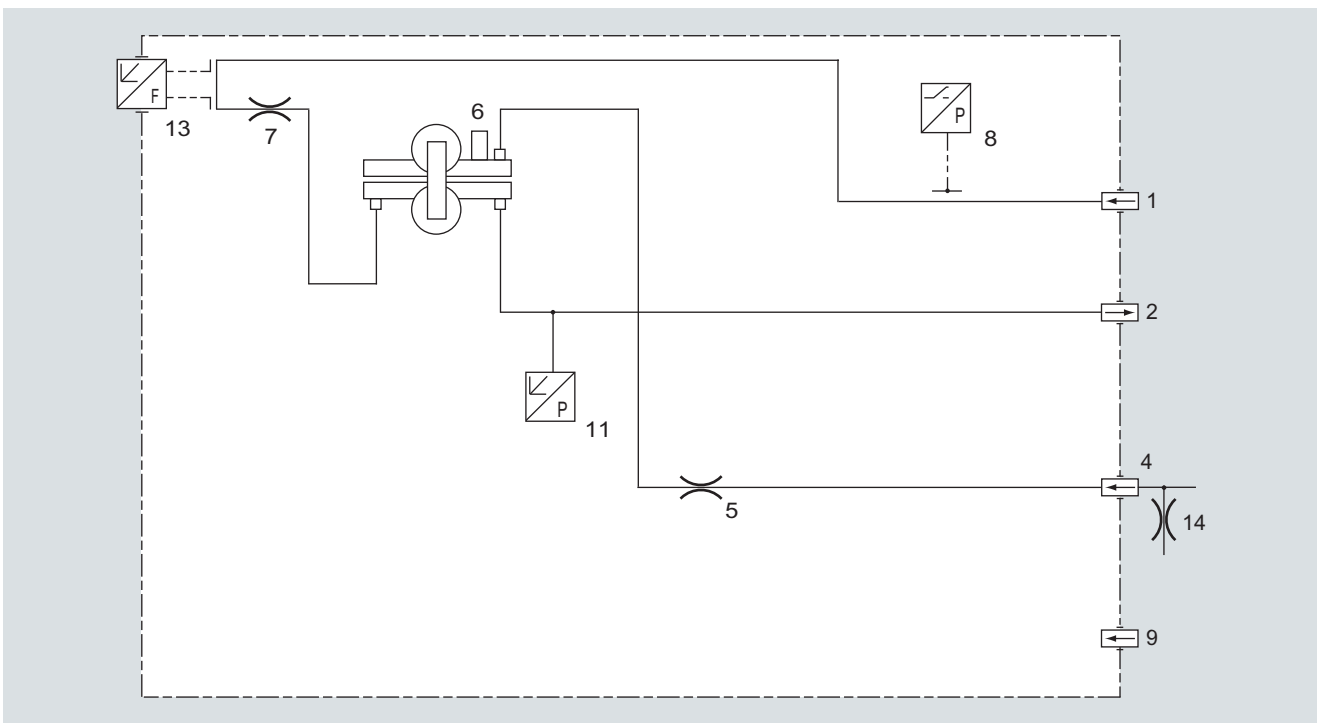

Gas path, reference gas connection 1 100 hPa, absolute

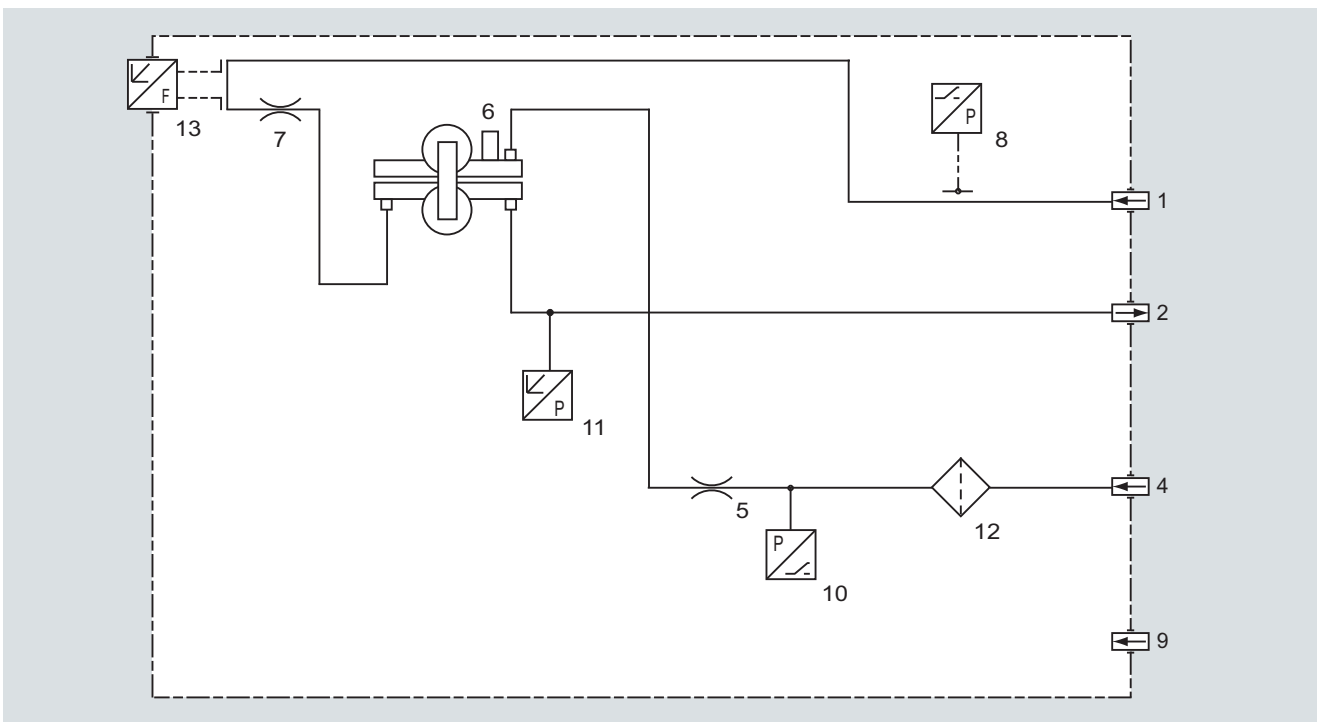

Gas path, reference gas connection 3 3 000 to 5 000 hPa, absolute

Continuous Gas Analyzer, extractive

OXYMAT 6

General information

Gas path (field device)

Legend for the gas path figures

1	Not used	8	Purging gas inlet (analyzer side)
2	Sample gas inlet	9	Pressure sensor
3	Reference gas inlet	10	O ₂ physical system
4	Sample gas outlet	11	Restrictor in sample gas path
5	Purging gas inlet (electronics side)	12	Flow indicator in reference gas path (option)
6	Purging gas outlet (electronics side)	13	Restrictor
7	Purging gas outlet (analyzer side)	14	Outlet restrictor

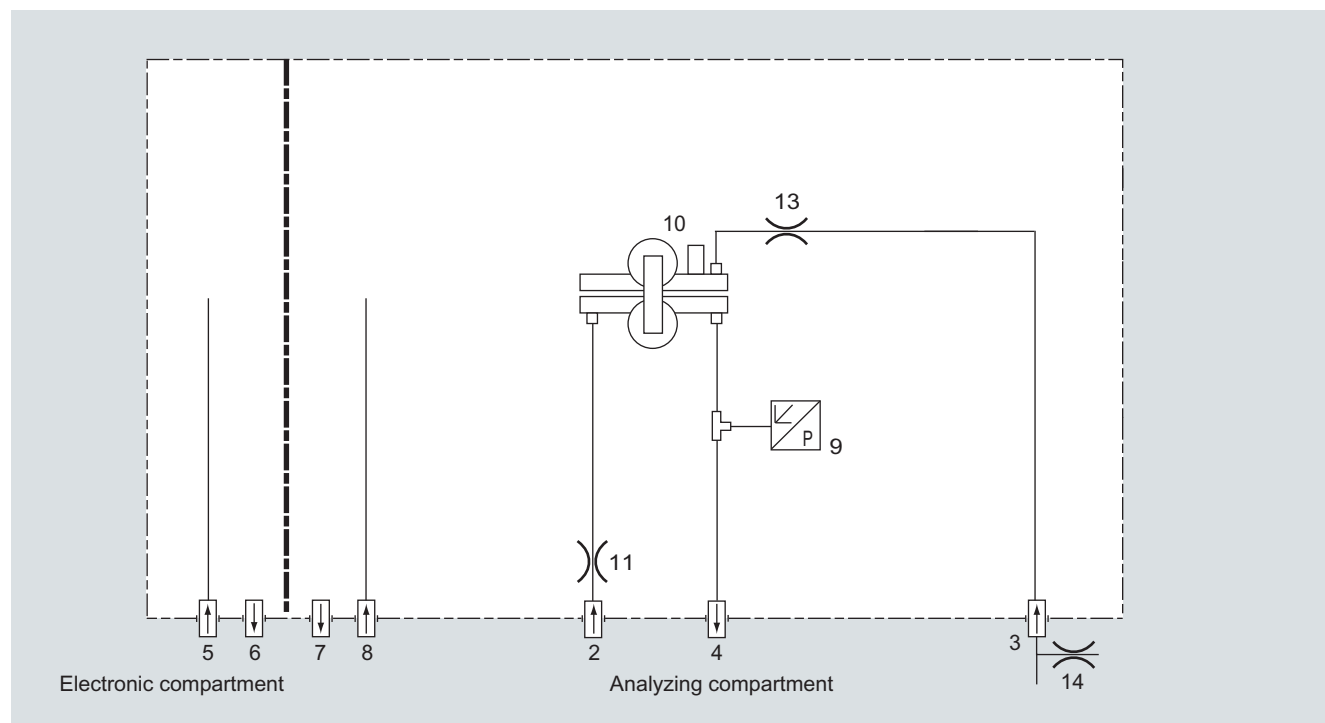

Gas path, reference gas connection 1 100 hPa, absolute

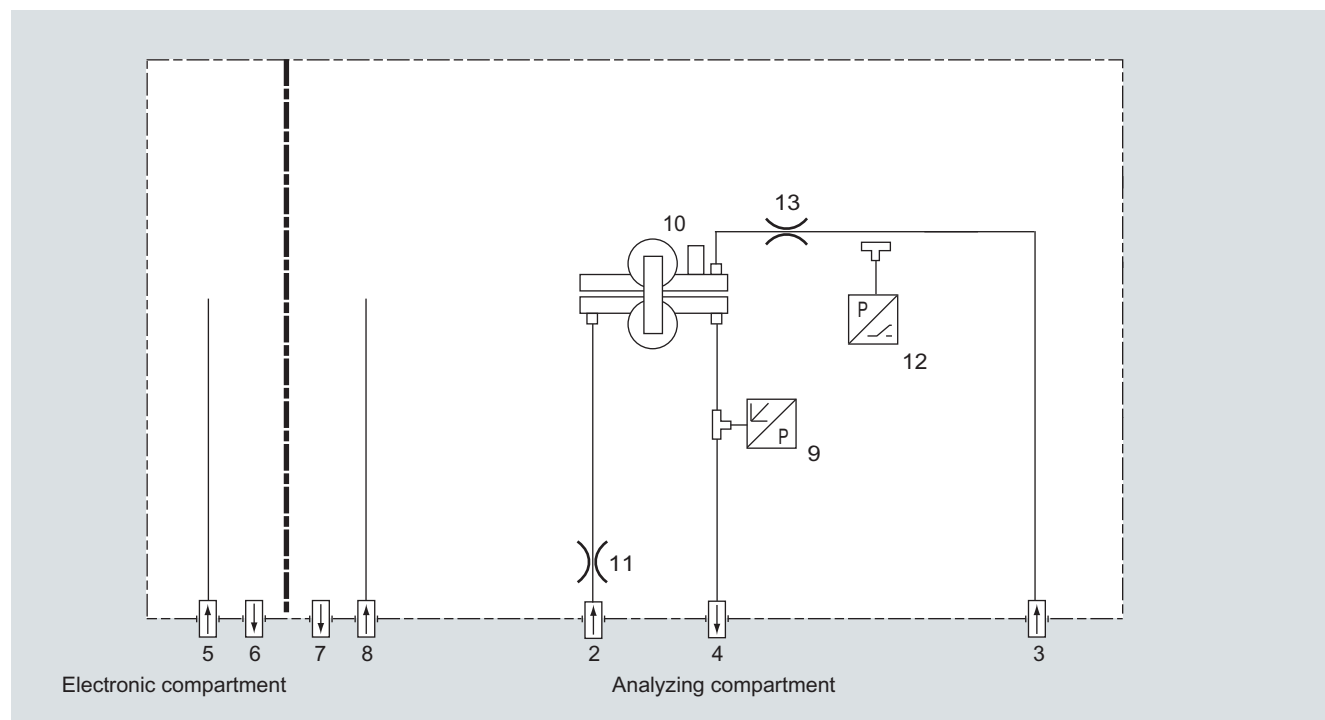

Gas path, reference gas connection 3 000 to 5 000 hPa, absolute

Function

Principle of operation

In contrast to almost all other gases, oxygen is paramagnetic. This property is utilized as the measuring principle by the OXYMAT 6 gas analyzers.

Oxygen molecules in an inhomogeneous magnetic field are drawn in the direction of increased field strength due to their paramagnetism. When two gases with different oxygen contents meet in a magnetic field, a pressure difference is produced between them.

In the case of OXYMAT 6, one gas (1) is a reference gas (N_2 , O_2 or air), the other is the sample gas (5). The reference gas is introduced into the sample chamber (6) through two channels (3). One of these reference gas streams meets the sample gas within the area of a magnetic field (7). Because the two channels are connected, the pressure, which is proportional to the oxygen content, causes a cross flow. This flow is converted into an electric signal by a microflow sensor (4).

The microflow sensor consists of two nickel-plated grids heated to approximately $120\text{ }^\circ\text{C}$, which, along with two supplementary resistors, form a Wheatstone bridge. The pulsating flow results in a change in the resistance of the Ni grids. This leads to an offset in the bridge which is dependent on the oxygen concentration of the sample gas.

Because the microflow sensor is located in the reference gas stream, the measurement is not influenced by the thermal conductivity, the specific heat or the internal friction of the sample gas. This also provides a high degree of corrosion resistance because the microflow sensor is not exposed to the direct influence of the sample gas.

By using a magnetic field with alternating strength (8), the effect of the background flow in the microflow sensor is not detected, and the measurement is thus independent of the instrument's operating position.

The sample chamber is directly in the sample path and has a small volume, and the microflow sensor is a low-lag sensor. This results in a very short response time for the OXYMAT 6.

Vibrations frequently occur at the place of installation and may falsify the measured signal (noise). A further microflow sensor (10) through which no gas passes acts as a vibration sensor. Its signal is applied to the measured signal as compensation.

If the density of the sample gas deviates by more than 50 % from that of the reference gas, the compensation microflow sensor (10) is flushed with reference gas just like the measuring sensor (4).

Note

The sample gases must be fed into the analyzers free of dust. Condensation should be prevented from occurring in the sample chambers. Therefore, the use of gas modified for the measuring task is necessary in most application cases.

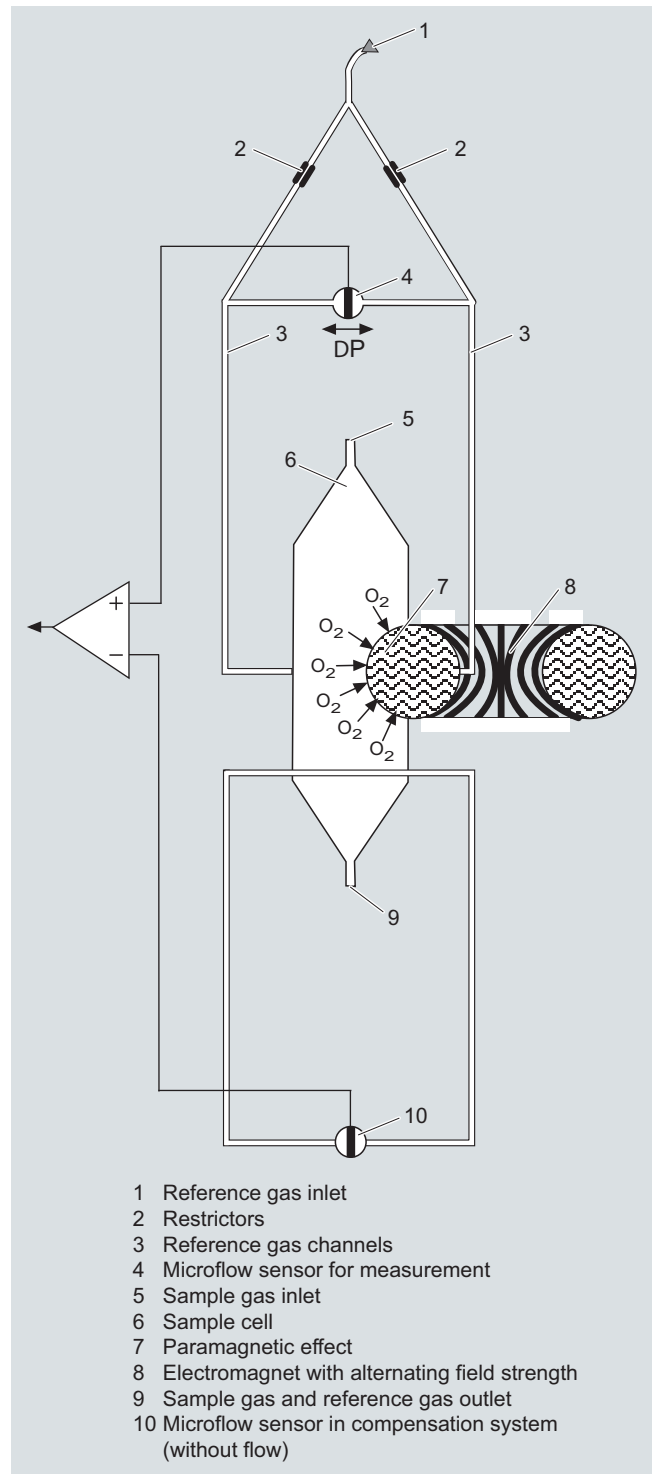

OXYMAT 6, principle of operation

Continuous Gas Analyzer, extractive

OXYMAT 6

General information

Advantages of the function-based application of reference gas

- The zero point can be defined specific to the application. It is then also possible to set "physically" suppressed zero points. For example, it is possible when using pure oxygen as the zero gas to set a measuring range of 99.5 to 100 % O₂ with a resolution of 50 ppm.
- The sensor (microflow sensor) is located outside the sample gas. Through use of an appropriate material in the gas path this also allows measurements in highly corrosive gases.
- Pressure variations in the sample gas can be compensated better since the reference gas is subjected to the same fluctuations.
- No influences on the thermal conductivity of the sample gas since the sensor is positioned on the reference gas side.
- The same gas is used for the serial gas calibration and as the reference gas. As a result of the low consumption of reference gas (3 to 10 ml/min), one calibration cylinder can be used for both gases.
- No measuring effect is generated in the absence of oxygen. The measured signal need not therefore be set electronically to zero, and is thus extremely stable with regard to temperature and electronic influences.

Essential characteristics

- Four freely parameterizable measuring ranges, also with suppressed zero point, all measuring ranges linear
- Measuring ranges with physically suppressed zero point possible
- Measuring range identification
- Galvanically isolated measured-value output 0/2/4 to 20 mA (also inverted)
- Autoranging possible; remote switching is also possible
- Storage of measured values possible during adjustments
- Wide range of selectable time constants (static/dynamic noise suppression); i.e. the response time of the analyzer can be matched to the respective measuring task
- Short response time
- Low long-term drift
- Measuring point switchover for up to 6 measuring points (programmable)
- Measuring point identification
- Internal pressure sensor for correction of pressure variations in sample gas range 500 to 2 000 hPa (abs.)
- External pressure sensor - only with piping as the gas path - can be connected for correction of variations in the sample gas pressure up to 3 000 hPa absolute (option)
- Monitoring of sample gas flow (option for version with hoses)
- Monitoring of sample gas and/or reference gas (option)
- Monitoring of reference gas with reference gas connection 3 000 to 5 000 hPa (abs.) (option)
- Automatic, parameterizable measuring range calibration
- Operation based on the NAMUR recommendation
- Two control levels with their own authorization codes for the prevention of accidental and unauthorized operator interventions
- Simple handling using a numerical membrane keyboard and operator prompting
- Customer-specific analyzer options such as:
 - Customer acceptance
 - TAG labels
 - Drift recording
 - Clean for O₂ service
 - Kalrez gaskets
- Analyzer unit with flow-type compensation branch: a flow is passed through the compensation branch (option) to reduce the vibration dependency in the case of highly different densities of the sample and reference gases
- Sample chamber for use in presence of highly corrosive sample gases

Reference gases

Measuring range	Recommended reference gas	Reference gas connection pressure	Remarks
0 to ... vol.% O ₂	N ₂	2 000 ... 4 000 hPa above sample gas pressure (max. 5 000 hPa absolute)	The reference gas flow is set automatically to 5 ... 10 ml/min (up to 20 ml/min with flow-type compensation branch)
... to 100 vol.% O ₂ (suppressed zero point with full-scale value 100 vol.% O ₂)	O ₂		
Around 21 vol.% O ₂ (suppressed zero point with 21 vol.% O ₂ within the measuring span)	Air	100 hPa with respect to sample gas pressure which may vary by max. 50 hPa around the atmospheric pressure	

Reference gases for OXYMAT 6

Correction of zero point error / cross-sensitivities

Accompanying gas (concentration 100 vol.%)	Deviation from zero point in vol.% O ₂ absolute	Accompanying gas (concentration 100 vol.%)	Deviation from zero point in vol.% O ₂ absolute
Organic gases		Inert gases	
Ethane C ₂ H ₆	-0.49	Helium He	+0.33
Ethene (ethylene) C ₂ H ₄	-0.22	Neon Ne	+0.17
Ethine (acetylene) C ₂ H ₂	-0.29	Argon Ar	-0.25
1.2 butadiene C ₄ H ₆	-0.65	Krypton Kr	-0.55
1.3 butadiene C ₄ H ₆	-0.49	Xenon Xe	-1.05
n-butane C ₄ H ₁₀	-1.26		
iso-butane C ₄ H ₁₀	-1.30	Inorganic gases	
1-butene C ₄ H ₈	-0.96	Ammonia NH ₃	-0.20
iso-butene C ₄ H ₈	-1.06	Hydrogen bromide HBr	-0.76
Dichlorodifluoromethane (R12) CCl ₂ F ₂	-1.32	Chlorine Cl ₂	-0.94
Acetic acid CH ₃ COOH	-0.64	Hydrogen chloride HCl	-0.35
n-heptane C ₇ H ₁₆	-2.40	Dinitrogen monoxide N ₂ O	-0.23
n-hexane C ₆ H ₁₄	-2.02	Hydrogen fluoride HF	+0.10
Cyclo-hexane C ₆ H ₁₂	-1.84	Hydrogen iodide HI	-1.19
Methane CH ₄	-0.18	Carbon dioxide CO ₂	-0.30
Methanol CH ₃ OH	-0.31	Carbon monoxide CO	+0.07
n-octane C ₈ H ₁₈	-2.78	Nitrogen oxide NO	+42.94
n-pentane C ₅ H ₁₂	-1.68	Nitrogen N ₂	0.00
iso-pentane C ₅ H ₁₂	-1.49	Nitrogen dioxide NO ₂	+20.00
Propane C ₃ H ₈	-0.87	Sulfur dioxide SO ₂	-0.20
Propylene C ₃ H ₆	-0.64	Sulfur hexafluoride SF ₆	-1.05
Trichlorofluoromethane (R11) CCl ₃ F	-1.63	Hydrogen sulfide H ₂ S	-0.44
Vinyl chloride C ₂ H ₃ Cl	-0.77	Water H ₂ O	-0.03
Vinyl fluoride C ₂ H ₃ F	-0.55	Hydrogen H ₂	+0.26
1.1 vinylidene chloride C ₂ H ₂ Cl ₂	-1.22		

Table 2: Zero point error due to diamagnetism or paramagnetism of some accompanying gases with reference to nitrogen at 60 °C und 1 000 hPa absolute (according to IEC 1207/3)

Conversion to other temperatures:

The deviations from the zero point listed in Table 2 must be multiplied by a correction factor (k):

- with diamagnetic gases: $k = 333 \text{ K} / (9 [^{\circ}\text{C}] + 273 \text{ K})$
- with paramagnetic gases: $k = [333 \text{ K} / (9 [^{\circ}\text{C}] + 273 \text{ K})]^2$

(all diamagnetic gases have a negative deviation from zero point)

Continuous Gas Analyzer, extractive

OXYMAT 6

19" rack unit

Technical specifications

General information

Measuring ranges	4, internally and externally switchable; autoranging is also possible
Smallest possible span (relating to sample gas pressure 1 000 hPa absolute, 0.5 l/min sample gas flow and 25 °C ambient temperature)	0.5 vol.%, 2 vol.% or 5 vol.% O ₂
Largest possible measuring span	100 vol.% O ₂ (for a pressure above 2 000 hPa: 25 vol.% O ₂)
Measuring ranges with suppressed zero point	Any zero point can be implemented within 0 ... 100 vol.%, provided that a suitable reference gas is used (see Table 1 in "Function")
Operating position	Front wall, vertical
Conformity	CE mark in accordance with EN 50081-1, EN 50082-2

Design, enclosure

Degree of protection	IP20 according to EN 60529
Weight	Approx. 13 kg

Electrical characteristics

Power supply	100 ... 120 V AC (nominal range of use 90 ... 132 V), 48 ... 63 Hz or 200 ... 240 V AC (nominal range of use 180 ... 264 V), 48 ... 63 Hz
Power consumption	Approx. 35 VA
EMC (E lectromagnetic C ompatibility)	In accordance with standard requirements of NAMUR NE21 (08/98), EN 61326, EN 50270 (with gas warning unit)
Electrical safety	According to EN 61010-1, over-voltage category III
Fuse values	100 ... 120 V: 1.0 T/250 200 ... 240 V: 0.63 T/250

Gas inlet conditions

Permissible sample gas pressure	500 ... 3 000 hPa absolute
• With pipes	500 ... 3 000 hPa absolute
• With hoses	
- Without pressure switch	500 ... 1 500 hPa absolute
- With pressure switch	500 ... 1 300 hPa absolute
Sample gas flow	18 ... 60 l/h (0.3 ... 1 l/min)
Sample gas temperature	Min. 0 ... max. 50 °C, but above the dew point
Sample gas humidity	< 90 % RH (RH: relative humidity)
Reference gas pressure (high-pressure version)	2 000 ... 4 000 hPa above sample gas pressure, but max. 5 000 hPa
Reference gas pressure (low-pressure version)	Min. 100 hPa above sample gas pressure

Dynamic response

Warm-up period	At room temperature < 30 min (the technical specification will be met after 2 hours)
Delayed display (T ₉₀ -time)	Min. 1.5 ... 3.5 s, depending on version
Damping (electrical time constant)	0 ... 100 s, parameterizable
Dead time (purging time of the gas path in the unit at 1 l/min)	Approximately 0.5 ... 2.5 s, depending on version
Time for device-internal signal processing	< 1 s

Pressure correction range

Pressure sensor	
• Internal	500 ... 2 000 hPa absolute
• External	500 ... 3 000 hPa absolute

Measuring response (relating to sample gas pressure 1 013 hPa absolute, 0.5 l/min sample gas flow and 25 °C ambient temperature)

Output signal fluctuation	< ± 0.75 % of the smallest possible measuring range according to rating plate, with electronic damping constant of 1 s (corresponds to ±0.25 % at 2 σ)
Zero point drift	< ± 0.5 %/month of the smallest possible span according to rating plate
Measured-value drift	< ±0.5 %/month of the current measuring range
Repeatability	< 1 % of the current measuring range
Detection limit	1 % of the current measuring range
Linearity error	< 0.1 % of the current measuring range

Influencing variables (relating to sample gas pressure 1 013 hPa absolute, 0.5 l/min sample gas flow and 25 °C ambient temperature)

Ambient temperature	< 0.5 %/10 K relating to the smallest possible measuring range according to rating plate, with measuring span 0.5 %: 1 %/10 K
Sample gas pressure (with air (100 hPa) as reference gas, correction of the atmospheric pressure fluctuations is only possible if the sample gas can vent to ambient air)	<ul style="list-style-type: none"> • When pressure compensation is switched off: < 2 % of the current measuring range/1 % pressure change • When pressure compensation is switched on: < 0.2 % of the current measuring range/1 % pressure change
Carrier gases	Deviation from zero point corresponding to paramagnetic or diamagnetic deviation of carrier gas
Sample gas flow at zero point	< 1 % of the current measuring range according to rating plate with a change in flow of 0.1 l/min within the permissible flow range
Power supply	< 0.1 % of the current measuring range with rated voltage ± 10 %

Electrical inputs and outputs

Analog output	0/2/4 ... 20 mA, isolated; max. load 750 Ω
Relay outputs	6, with changeover contacts, freely parameterizable, e.g. for measuring range identification; load: 24 V AC/DC/1 A, isolated
Analog inputs	2, dimensioned for 0/2/4 ... 20 mA for external pressure sensor and residual gas influence correction (correction of cross-interference)
Binary inputs	6, designed for 24 V, isolated, freely parameterizable, e.g. for measuring range switchover
Serial interface	RS 485
Options	AUTOCAL function with 8 addi- tional binary inputs and relay out- puts each, also with PROFIBUS PA or PROFIBUS DP

Climatic conditions

Permissible ambient temperature	-30 ... +70 °C during storage and transportation, 5 ... 45 °C during operation
Permissible humidity	< 90 % RH (RH: relative humidity) within average annual value, dur- ing storage and transportation (dew point must not be under- shot)

Continuous Gas Analyzer, extractive OXYMAT 6

19" rack unit

2

Selection and ordering data

Order No.

OXYMAT 6 gas analyzer

D) 7MB2021- 0 -

Cannot be combined

19" rack unit for installation in cabinets

Gas connections

- Pipe with 6 mm outer diameter
- Pipe with 1/4" outer diameter

0
1

Smallest possible span O₂

- 0.5 % reference gas pressure 3 000 hPa
- 0.5 % reference gas pressure 100 hPa (external pump)
- 2 % reference gas pressure 3 000 hPa
- 2 % reference gas pressure 100 hPa (external pump)
- 5% reference gas pressure 3 000 hPa
- 5% reference gas pressure 100 hPa (external pump)

A
B
C
D
E
F

A → E30
B → E30, Y02
D → E30, Y02
F → E30, Y02

Sample chamber

Non-flow-type compensation branch

- Made of stainless steel, mat. no. 1.4571
- Made of tantalum

A
B

Flow-type compensation branch

- Made of stainless steel, mat. no. 1.4571
- Made of tantalum

C
D

C
D

Internal gas paths

- Hose made of FKM (Viton)
- Pipe made of titanium
- Pipe made of stainless steel, mat. no. 1.4571

0
1
2

1 → Y02

Power supply

- 100 ... 120 V AC, 48 ... 63 Hz
- 200 ... 240 V AC, 48 ... 63 Hz

0
1

Monitoring (reference gas, sample gas)

- Without
- Reference gas only
- Reference gas and sample gas (with flow indicator and pressure switch for sample gas)
- Sample gas only

A
B
C
D

A → E30
C → E30
D → E30

Add-on electronics

- Without
- AUTOCAL function
 - With 8 additional binary inputs/outputs
 - With serial interface for the automotive industry (AK)
 - With 8 additional binary inputs/outputs and PROFIBUS PA interface
 - With 8 additional binary inputs/outputs and PROFIBUS DP interface

A
B
D
E
F

D → E20

Language

- German
- English
- French
- Spanish
- Italian

0
1
2
3
4

Additional versions

Order code

Cannot be combined

Add "-Z" to Order No. and specify order codes.

- Telescopic rails (2 units)
- Kalrez gaskets in sample gas path
- TAG labels (specific inscription based on customer information)
- FM/CSA certificate – Class I Div 2
- ATEX II G certificate; safety-related measurements in non-hazardous gas zone
- Clean for O₂ service (specially cleaned gas path)
- Measuring range indication in plain text, if different from the standard setting

A31
B01
B03
E20
E30
Y02
Y11

→ E30
→ E20

D) Subject to export regulations AL: 9I999, ECCN: N

Selection and ordering data

Retrofitting sets

- RS 485/Ethernet converter
- RS 485/RS 232 converter
- RS 485/USB converter
- AUTOCAL function with serial interface for the automotive industry (AK)
- AUTOCAL function with 8 binary inputs/outputs
- AUTOCAL function with 8 binary inputs/outputs and PROFIBUS PA
- AUTOCAL function with 8 binary inputs/outputs and PROFIBUS DP
- D) Subject to export regulations AL: 9I999, ECCN: N

Order No.

- A5E00852383
- C79451-Z1589-U1
- D) A5E00852382
- C79451-A3480-D512
- C79451-A3480-D511
- A5E00057307
- A5E00057312

Dimensional drawings

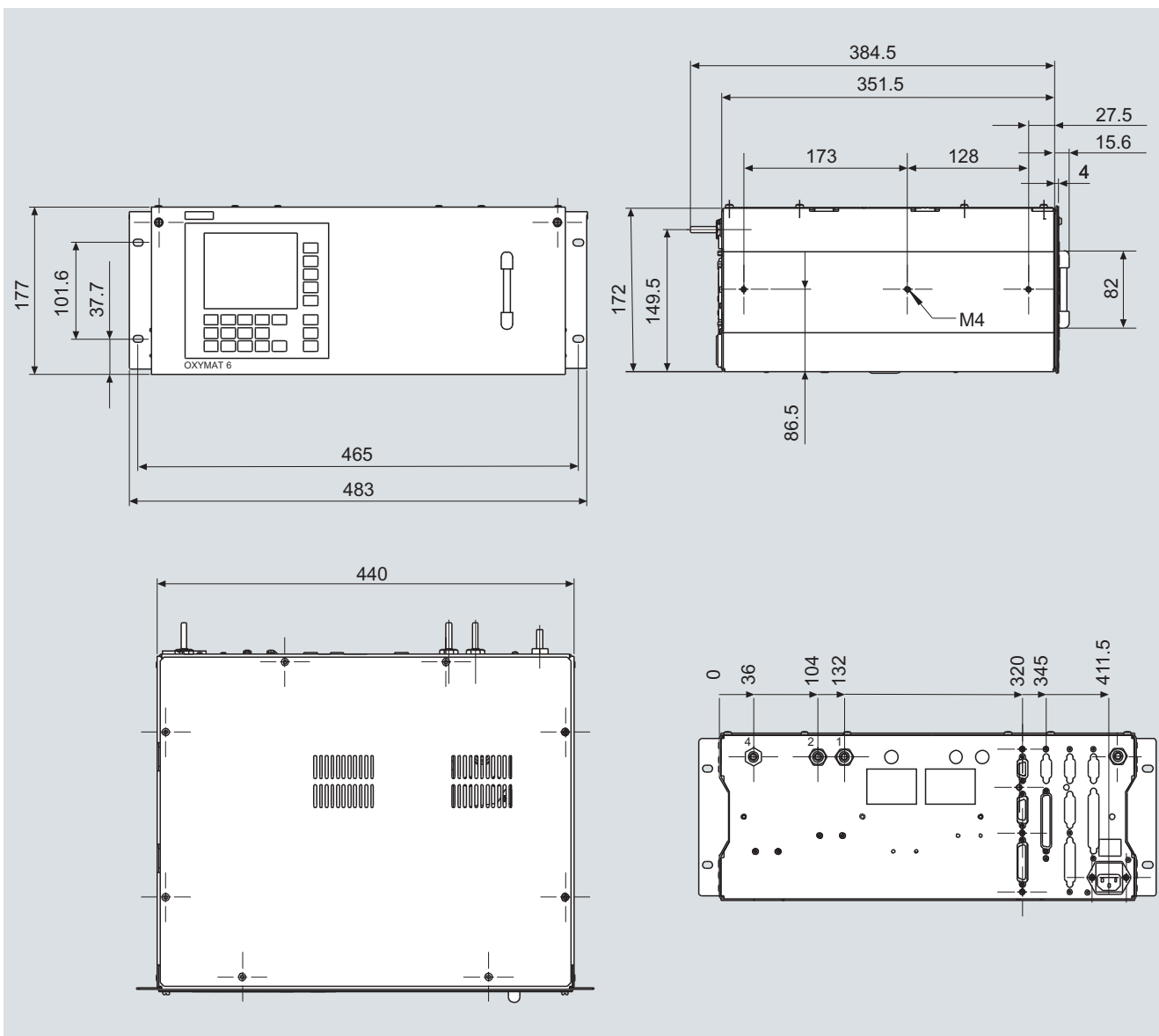

OXYMAT 6, 19" unit, dimensions in mm

Continuous Gas Analyzer, extractive OXYMAT 6

19" rack unit

Schematics

Pin assignment (electrical and gas connections)

2

Connector SUB-D 9F (RS 485)

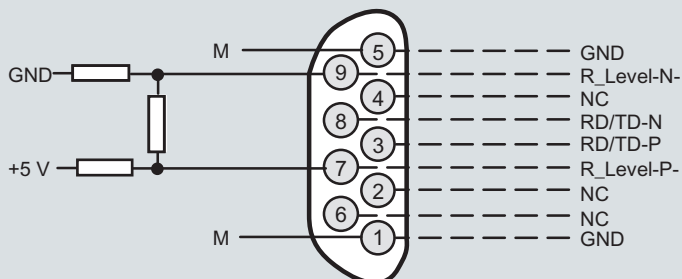

It is possible to connect bus terminating resistors to pins 7 and 9.

SUB-D 15F connector

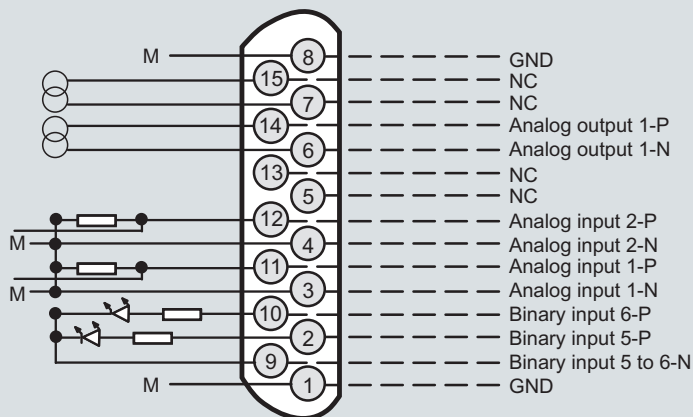

Analog outputs isolated (also from each other), $R_L \leq 750 \Omega$

Correction of pressure or cross-interference
Correction of cross-interference
Correction of cross-interference

Analog inputs non-isolated, 0 ... 20 mA/500 Ω or 0 ... 10 V (low resistance)

SUB-D 25F connector

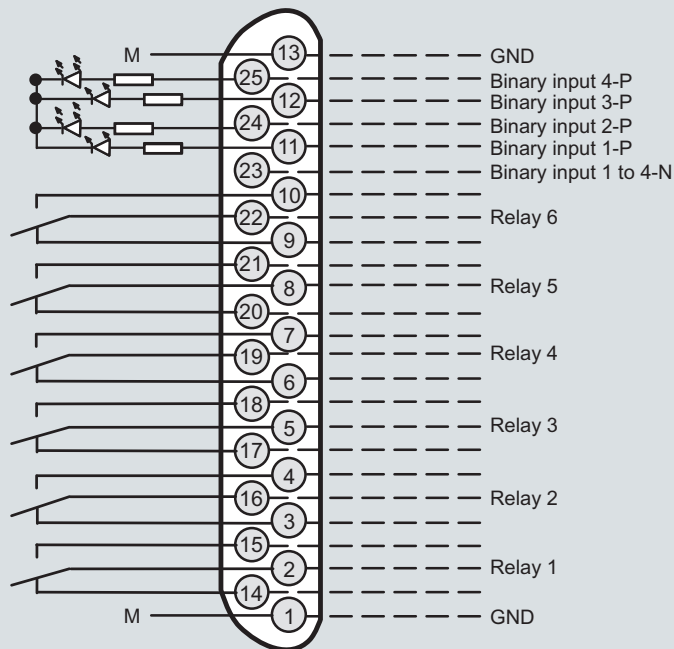

Isolated via optocoupler
"0" = 0 V (0 ... 4.5 V)
"1" = 24 V (13 ... 33 V)

Contact load max. 24 V/1 A, AC/DC
relay contacts shown:
relay coil has zero current

Note:
All cables to the connectors or terminal blocks must be shielded and rest against the enclosure potential.

OXYMAT 6, 19" unit, pin assignment

Connector SUB-D 37F (option)

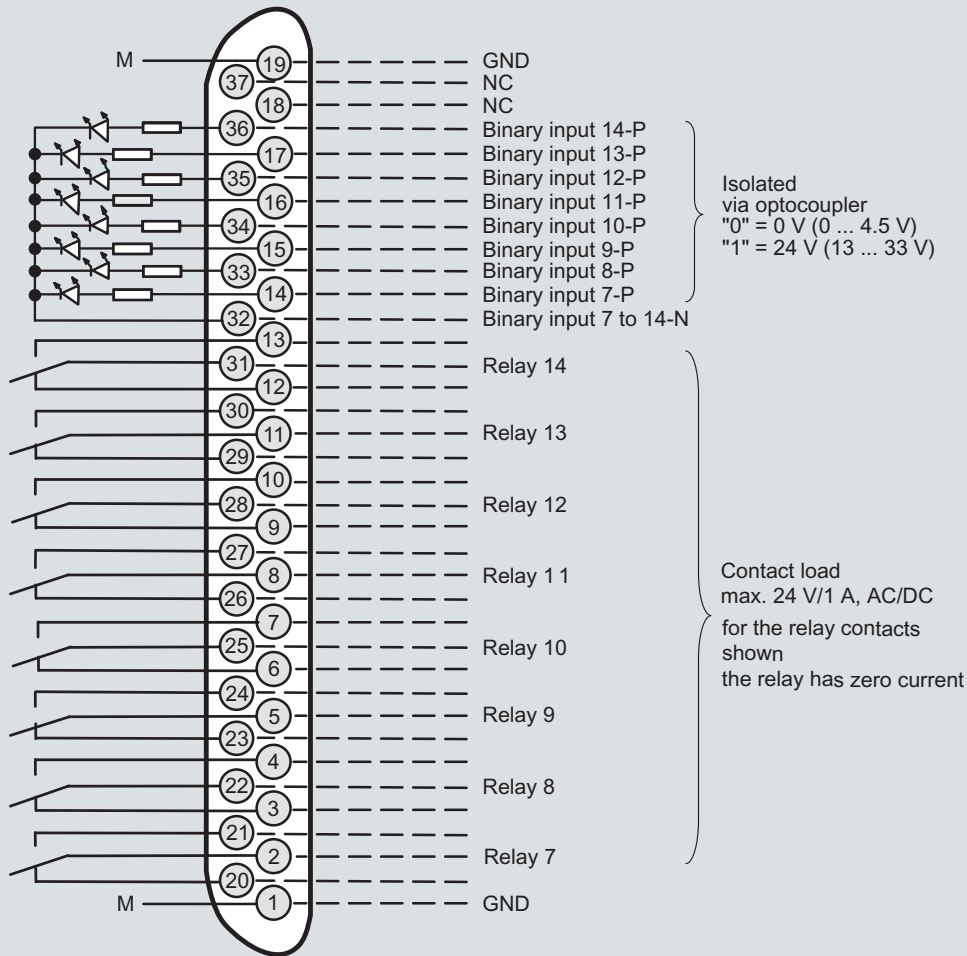

Connector SUB-D 9F PROFIBUS DP

optional

Connector SUB-D 9M PROFIBUS PA

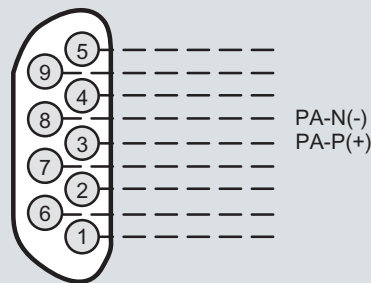
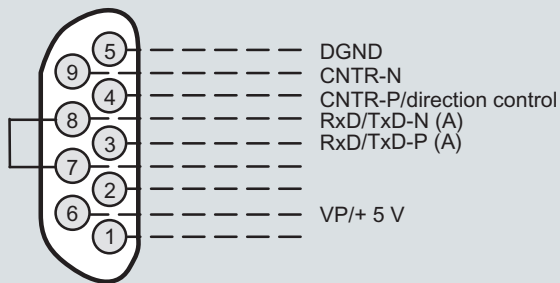

Note:

All cables to the connectors or terminal blocks must be shielded and rest against the enclosure potential.

Continuous Gas Analyzer, extractive OXYMAT 6

19" rack unit

2

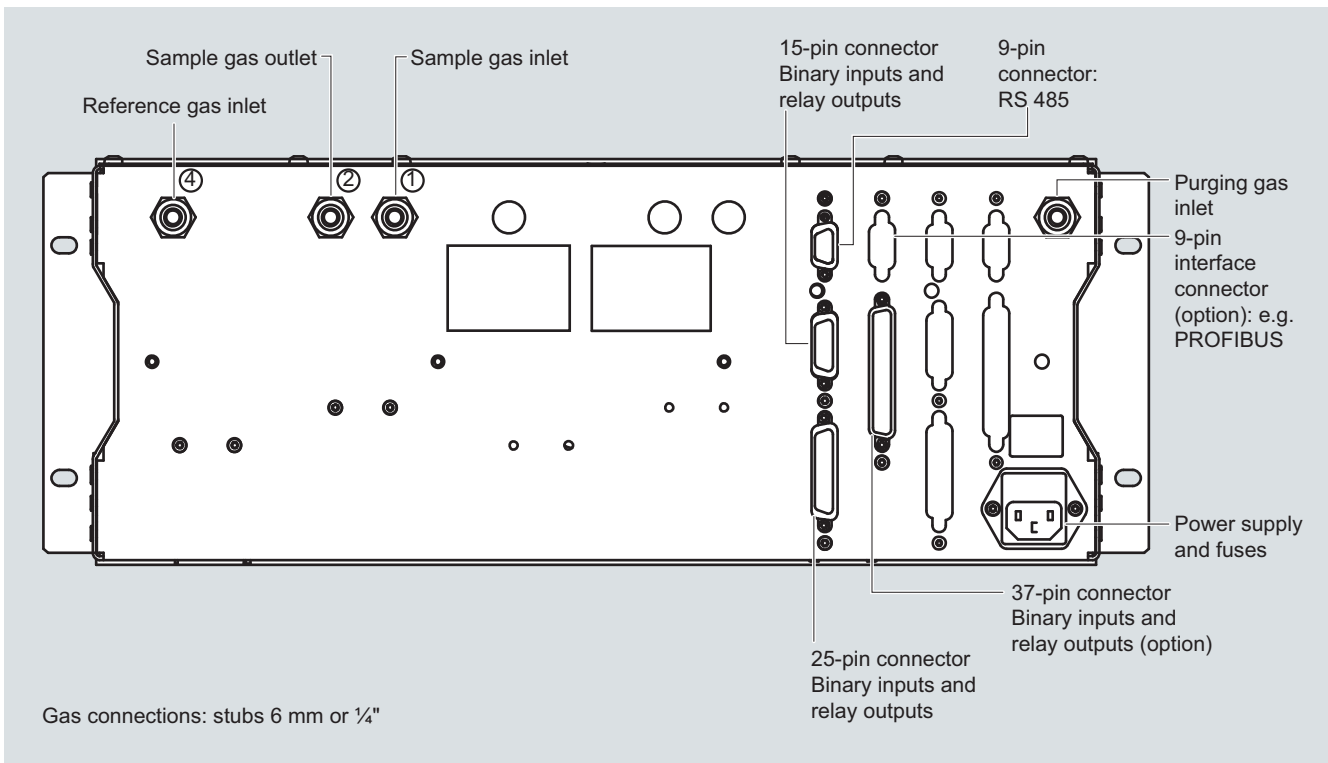

OXYMAT 6, 19" unit, gas and electrical connections

Technical specifications**General information**

Measuring ranges	4, internally and externally switchable; autoranging is also possible
Smallest possible span (relating to sample gas pressure 1 000 hPa absolute, 0.5 l/min sample gas flow and 25 °C ambient temperature), smallest possible span with heated version: 0.5 % (< 65 °C); 0.5 ... 1 % (65 ... 90 °C); 1 ... 2 % (90 ... 130 °C))	0.5 vol.%, 2 vol.% or 5 vol.% O ₂
Largest possible measuring span	100 vol.% O ₂ (for a pressure above 2 000 hPa: 25 vol.% O ₂)
Measuring ranges with suppressed zero point	Any zero point can be implemented within 0 ... 100 vol.%, provided that a suitable reference gas is used (see Table "Reference gases for OXYMAT 6", page 2/101)
Operating position	Front wall, vertical
Conformity	CE mark in accordance with EN 50081-1, EN 50082-2

Design, enclosure

Degree of protection	IP65 in accordance with EN 60529, restricted breathing enclosure to EN 50021
Weight	Approx. 28 kg

Electrical characteristics

Power supply	100 ... 120 V AC (nominal range of use 90 ... 132 V), 48 ... 63 Hz or 200 ... 240 V AC (nominal range of use 180 ... 264 V), 48 ... 63 Hz
Power consumption	Approx. 35 VA, approx. 330 VA with heated version
EMC (Electromagnetic Compatibility)	In accordance with standard requirements of NAMUR NE21 (08/98), EN 61326, EN 50270 (with gas warning unit)
Electrical safety	In accordance with EN 61010-1
• Heated units	Overvoltage category II
• Unheated units	Overvoltage category III
Fuse values (unheated unit)	
• 100 ... 120 V	F3: 1 T/250; F4: 1 T/250
• 200 ... 240 V	F3: 0.63 T/250; F4: 0.63 T/250
Fuse values (heated unit)	
• 100 ... 120 V	F1: 1 T/250; F2: 4 T/250 F3: 4 T/250; F4: 4 T/250
• 200 ... 240 V	F1: 0.63 T/250; F2: 2.5 T/250 F3: 2.5 T/250; F4: 2.5 T/250

Gas inlet conditions

Permissible sample gas pressure	
• With pipes	500 ... 3 000 hPa absolute
• With pipes, Ex version	
- Leakage compensation	500 ... 1 160 hPa absolute
- Continuous purging	500 ... 3 000 hPa absolute
Reference gas pressure (high-pressure version)	2 000 ... 4 000 hPa above sample gas pressure, but max. 5 000 hPa
Reference gas pressure (low-pressure version)	Min. 100 hPa above sample gas pressure
Purging gas pressure	
• Permanent	< 165 hPa above ambient pressure
• For short periods	Max. 250 hPa above ambient pressure
Sample gas flow	18 ... 60 l/h (0.3 ... 1 l/min)
Sample gas temperature	• Min. 0 ... max. 50 °C, but above the dew point (unheated) • 15 °C above temperature analyzer unit (heated)
Sample gas humidity	< 90 % relative humidity

Dynamic response

Warm-up period	At room temperature < 30 min (the technical specification will be met after 2 hours)
Delayed display (t ₉₀ -time)	< 1.5 s
Damping (electrical time constant)	0 ... 100 s, parameterizable
Dead time (purging time of the gas path in the unit at 1 l/min)	Approx. 0.5 s
Time for device-internal signal processing	< 1 s

Pressure correction range

Pressure sensor	
• Internal	500 ... 2 000 hPa absolute
• External	500 ... 3 000 hPa absolute

Measuring response (relating to sample gas pressure 1 013 hPa absolute, 0.5 l/min sample gas flow and 25 °C ambient temperature)

Output signal fluctuation	< ± 0.75 % of the smallest possible measuring range according to rating plate, with electronic damping constant of 1 s (corresponds to ± 0.25 % at 2 σ)
Zero point drift	< ± 0.5 %/month of the smallest possible span according to rating plate
Measured-value drift	< ± 0.5 %/month of the current measuring range
Repeatability	< 1 % of the current measuring range
Detection limit	1 % of the current measuring range
Linearity error	< 0.1 % of the current measuring range

Continuous Gas Analyzer, extractive

OXYMAT 6

Field device

Influencing variables (relating to sample gas pressure 1 013 hPa absolute, 0.5 l/min sample gas flow and 25 °C ambient temperature)

Ambient temperature	< 0.5 %/10 K relating to the smallest possible measuring range according to rating plate, with measuring span 0.5 %: 1 %/10 K
Sample gas pressure (with air (100 hPa) as reference gas, correction of the atmospheric pressure fluctuations is only possible if the sample gas can vent to ambient air)	<ul style="list-style-type: none"> • When pressure compensation is switched off: < 2 % of the current measuring range/1 % pressure change • When pressure compensation is switched on: < 0.2 % of the current measuring range/1 % pressure change
Carrier gases	Deviation from zero point corresponding to paramagnetic or diamagnetic deviation of carrier gas
Sample gas flow at zero point	< 1 % of the current measuring range according to rating plate with a change in flow of 0.1 l/min within the permissible flow range; heated version up to double error
Power supply	< 0.1 % of the current measuring range with rated voltage \pm 10 %

Electrical inputs and outputs

Analog output	0/2/4 ... 20 mA, isolated; max. load 750 Ω
Relay outputs	6, with changeover contacts, freely parameterizable, e.g. for measuring range identification; load: 24 V AC/DC/1 A, isolated
Analog inputs	2, dimensioned for 0/2/4 ... 20 mA for external pressure sensor and residual gas influence correction (correction of cross-interference)
Binary inputs	6, designed for 24 V, isolated, freely parameterizable, e.g. for measuring range switchover
Serial interface	RS 485
Options	AUTOCAL function with 8 additional binary inputs and relay outputs each, also with PROFIBUS PA or PROFIBUS DP

Climatic conditions

Permissible ambient temperature	-30 ... +70 °C during storage and transportation, 5 ... 45 °C during operation
Permissible humidity	< 90 % RH (relative humidity) as annual average (maximum accuracy achieved after 2 hours), during storage and transportation (dew point must not be under-shot)



Selection and ordering data	Order No.	
OXYMAT 6 gas analyzer for field installation	D) 7MB2011- 0 -	Cannot be combined
<u>Gas connections for sample gas and reference gas</u> Ferrule screw connection made of stainless steel (mat. no. 1.4571) • Pipe with 6 mm outer diameter • Pipe with 1/4" outer diameter	0 1	0 → D02 1 → D01
Ferrule screw connection made of titanium • Pipe with 6 mm outer diameter • Pipe with 1/4" outer diameter	2 3	2 → D01, D02, Y02 3 → D01, D02, Y02
<u>Piping and gas connections made of Hastelloy C22:</u> 7MB2011-0/1... + order code D01 or D02		
<u>Smallest possible span O₂</u> 0.5 % reference gas pressure 3 000 hPa 0.5 % reference gas pressure 100 hPa (external pump) 2 % reference gas pressure 3 000 hPa	A B C D E F	A → E30 ... E33 B B B → Y02, E30 ... E33 D D → Y02, E30 ... E33 F F → Y02, E30 ... E33
2 % reference gas pressure 100 hPa (external pump) 5 % reference gas pressure 3 000 hPa 5 % reference gas pressure 100 hPa (external pump)		
<u>Sample chamber</u> Non-flow-type compensation branch • Made of stainless steel, mat. no. 1.4571 • Made of tantalum Flow-type compensation branch • Made of stainless steel, mat. no. 1.4571 • Made of tantalum	A B C D	C D
<u>Heating of internal gas paths and analyzer unit</u> Without With (65 ... 130 °C)	0 1	1
<u>Power supply</u> Standard unit and acc. to ATEX II 3G version (Zone 2) • 100 ... 120 V AC, 48 ... 63 Hz • 200 ... 240 V AC, 48 ... 63 Hz ATEX II 2G versions (Zone 1), incl. certificate • 100 ... 120 V AC, 48 ... 63 Hz, according to ATEX II 2G ¹⁾ (operating mode: leakage compensation) • 200 ... 240 V AC, 48 ... 63 Hz, according to ATEX II 2G ¹⁾ (operating mode: leakage compensation) • 100 ... 120 V AC, 48 ... 63 Hz, according to ATEX II 2G ¹⁾ (operating mode: continuous purging) • 200 ... 240 V AC, 48 ... 63 Hz, according to ATEX II 2G ¹⁾ (operating mode: continuous purging)	0 1 2 3 6 7	0 1 2 2 2 → E11, E12 3 3 3 → E11, E12 6 6 6 → E11, E12 7 7 7 → E11, E12
<u>Reference gas monitoring</u> Without With	A B	B A
<u>Add-on electronics</u> Without AUTOCAL function • With 8 additional binary inputs and 8 additional relay outputs • With 8 additional binary inputs/outputs and PROFIBUS PA interface • With 8 additional binary inputs/outputs and PROFIBUS DP interface • With 8 additional binary inputs/outputs and PROFIBUS PA Ex-i	A B E F G	E → E12 F → E12 G
<u>Language</u> German English French Spanish Italian	0 1 2 3 4	

D) Subject to export regulations AL: 9I999, ECCN: N
1) See also next page, "Additional units for Ex versions".

Continuous Gas Analyzer, extractive

OXYMAT 6

Field device

Selection and ordering data

<i>Additional versions</i>	Order code	Cannot be combined
Add "-Z" to Order No. and specify order codes.		
Set of Torx screwdrivers	A32	
Kalrez gaskets in sample gas path	B01	
TAG labels (specific inscription based on customer information)	B03	
Gas connections and piping made of Hastelloy C22		
• Outer diameter 6 mm	D01	→ E20
• Outer diameter ¼"	D02	→ E20
<u>Ex versions</u>		
For possible combinations, see Table "Ex configurations – principle selection criteria", page 6/16		
ATEX II 3G certificate; restricted breathing enclosure, non-flammable gases	E11	
ATEX II 3G certificate; flammable gases	E12	
CSA certificate – Class I Div 2	E20	
ATEX II G certificate; safety-related measurements		
• In non-hazardous gas zone	E30	
• In Ex zone acc. to ATEX II 2G, leakage compensation	E31	
• In Ex zone acc. to ATEX II 2G, continuous purging	E32	
• In Ex zone acc. to ATEX II 3G, flammable and non-flammable gases	E33	
- Extended element with heated units; 110/120 V	E38	
- Extended element with heated units; 220/240 V	E39	
ATEX II 3D certificate; potentially explosive dust atmospheres		
• In non-hazardous gas zone	E40	
• In Ex zone acc. to ATEX II 3G, non-flammable gases	E41	
• In Ex zone acc. to ATEX II 3G, flammable gases ¹⁾	E42	
Clean for O ₂ service (specially cleaned gas path)	Y02	
Measuring range indication in plain text, if different from the standard setting	Y11	
<u>Additional units for Ex versions</u>	Order No.	
<u>Category ATEX II 2G (Zone 1)</u>		
BARTEC EEx p control unit, 230 V, "leakage compensation"	7MB8000-2BA	
BARTEC EEx p control unit, 115 V, "leakage compensation"	7MB8000-2BB	
BARTEC EEx p control unit, 230 V, "continuous purging"	7MB8000-2CA	
BARTEC EEx p control unit, 115 V, "continuous purging"	7MB8000-2CB	
Ex isolation amplifier	7MB8000-3AA	
Ex isolating relay, 230 V	7MB8000-4AA	
Ex isolating relay, 110 V	7MB8000-4AB	
Differential pressure switch for corrosive and non-corrosive gases	7MB8000-5AA	F)
Stainless steel flame arrestor	7MB8000-6BA	
Hastelloy flame arrestor	7MB8000-6BB	
<u>Category ATEX II 3G (Zone 2)</u>		
BARTEC EEx p control unit, 230 V, "continuous purging"	7MB8000-2CA	
BARTEC EEx p control unit, 115 V, "continuous purging"	7MB8000-2CB	
<u>FM/CSA (Class I Div. 2)</u>		
Ex purging unit MiniPurge FM	7MB8000-1AA	
<u>Retrofitting sets</u>		
RS 485/Ethernet converter	A5E00852383	
RS 485/RS 232 converter	C79451-Z1589-U1	
RS 485/USB converter	A5E00852382	
AUTOCAL function with 8 binary inputs/outputs	A5E00064223	
AUTOCAL function with 8 binary inputs/outputs and PROFIBUS PA	A5E00057315	
AUTOCAL function with 8 binary inputs/outputs and PROFIBUS DP	A5E00057318	
AUTOCAL function with 8 binary inputs/outputs and PROFIBUS PA Ex i (firmware 4.1.10 required)	A5E00057317	

F) Subject to export regulations AL: N, ECCN: EAR99H

1) Only in connection with an approved purging unit

Dimensional drawings

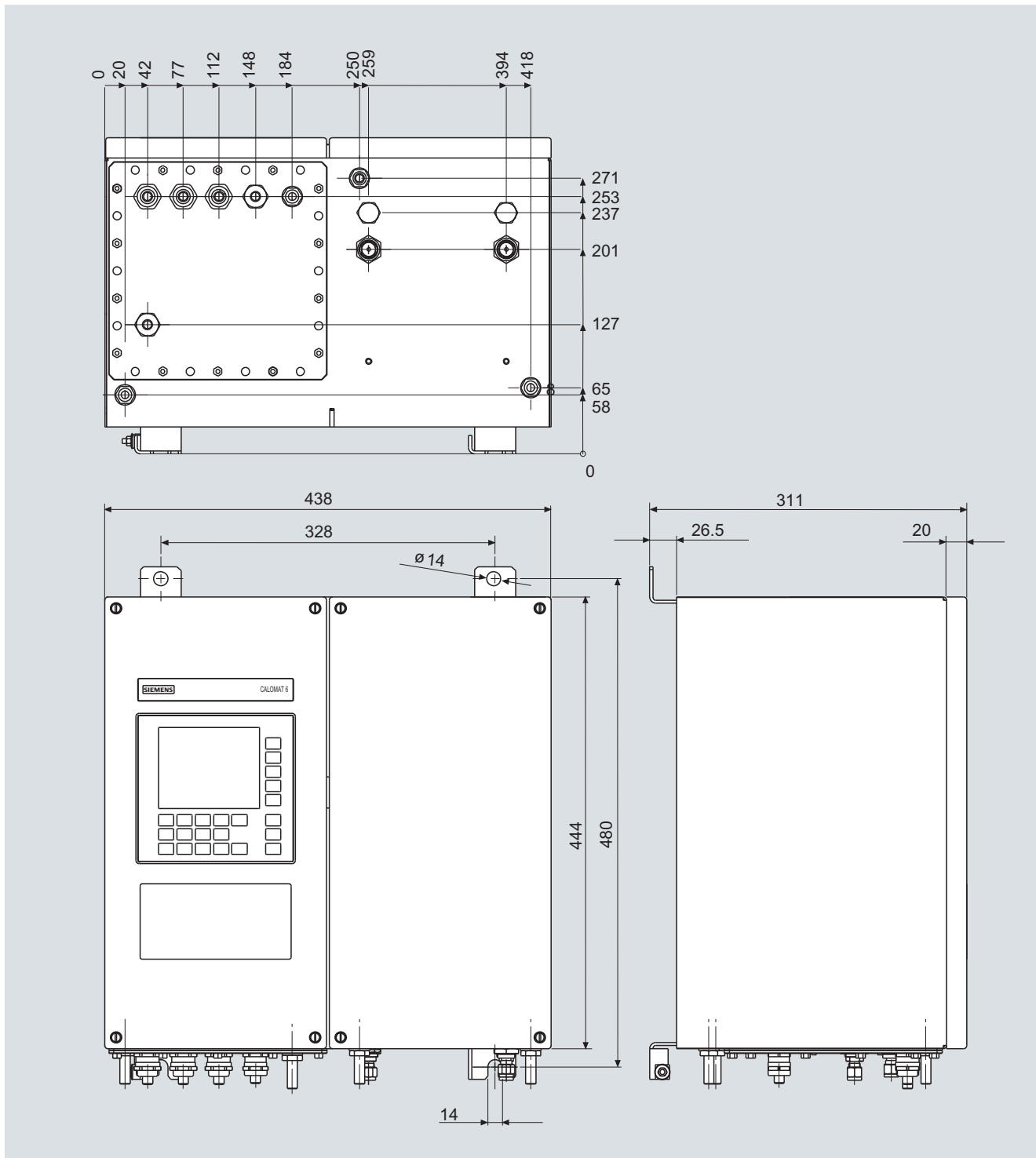

OXYMAT 6, field unit, dimensions in mm

Continuous Gas Analyzer, extractive OXYMAT 6

Field device

Schematics

Pin assignment (electrical and gas connections)

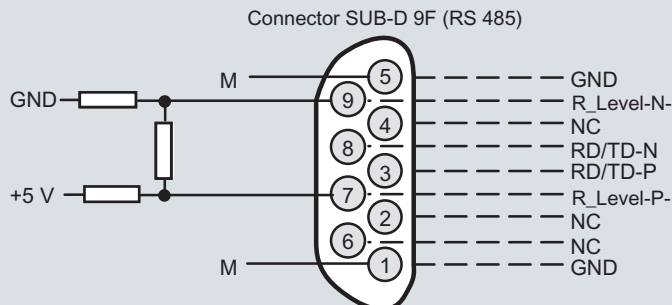

It is possible to connect bus terminating resistors to pins 7 and 9.

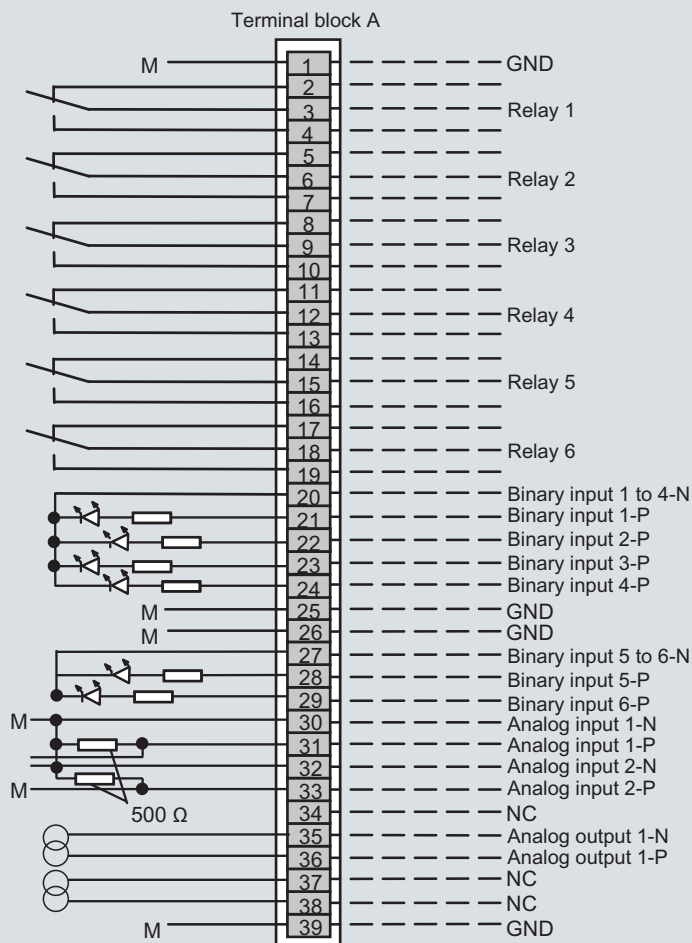

Contact load max.
24 V/1 A, AC/DC; relay contacts shown: relay coil has zero current

Isolated via optocoupler
"0" = 0 V (0 ... 4.5 V)
"1" = 24 V (13 ... 33 V)

Isolated via optocoupler
"0" = 0 V (0 ... 4.5 V)
"1" = 24 V (13 ... 33 V)

Correction of cross-interference } Analog inputs non-isolated,
Pressure correction } 0 ... 20 mA or 0 ... 10 V
(internal resistance ≤ 500 Ω)

} Analog outputs isolated

Note:
All cables to the connectors or terminal blocks must be shielded and rest against the enclosure potential.

OXYMAT 6, field unit, connector and terminal assignment

Terminal block B (option)

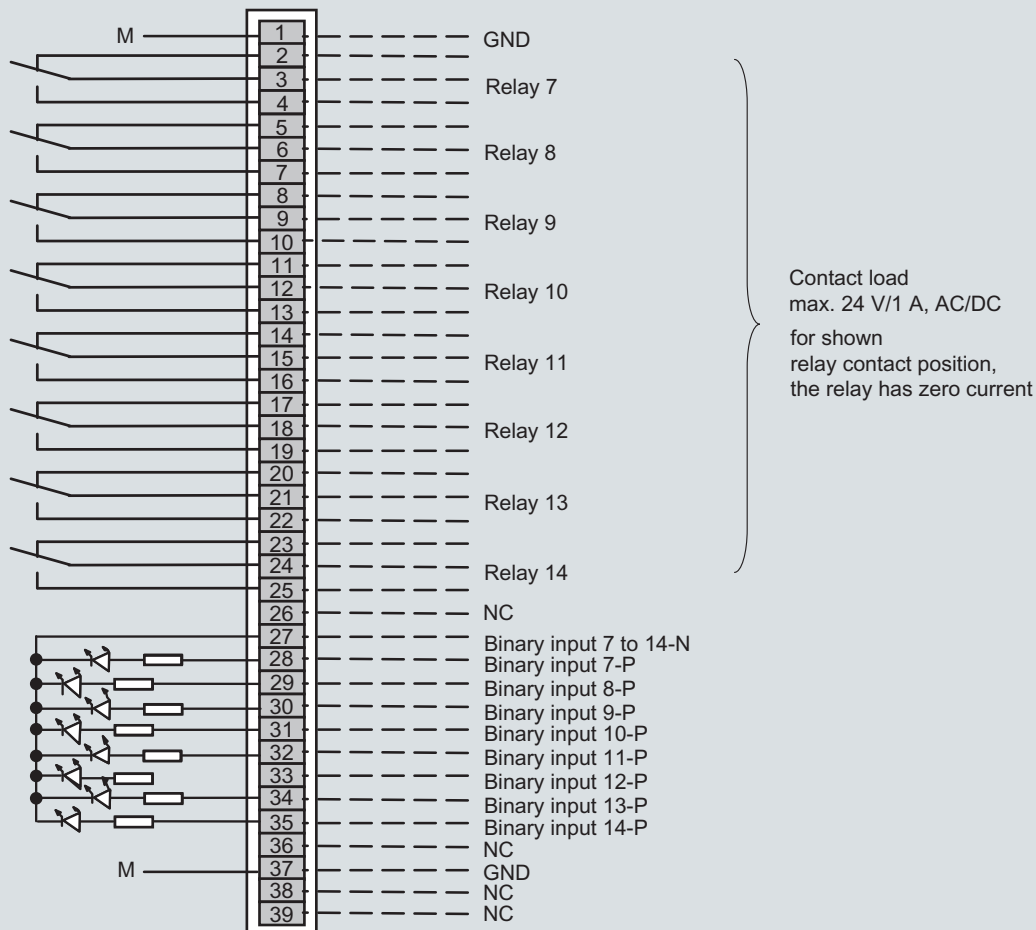

Connector SUB-D 9F-X90
PROFIBUS DP

optional

Connector SUB-D 9M-X90
PROFIBUS PA

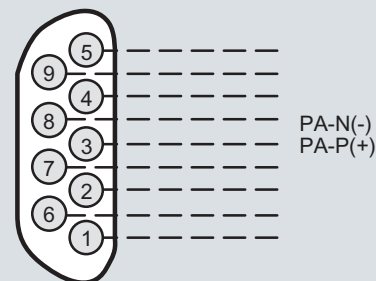
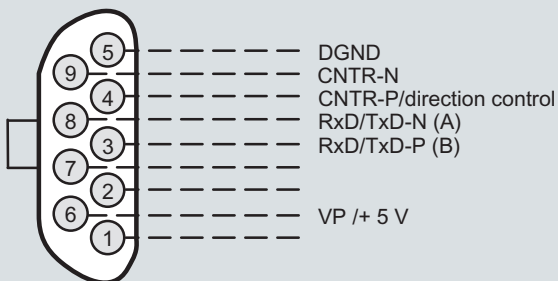

Note:
All cables to the connectors or terminal blocks must be shielded and rest against the enclosure potential.

OXYMAT 6, field unit, connector and terminal assignment of the AUTOCAL board and PROFIBUS connectors

Continuous Gas Analyzer, extractive

OXYMAT 6

Field device

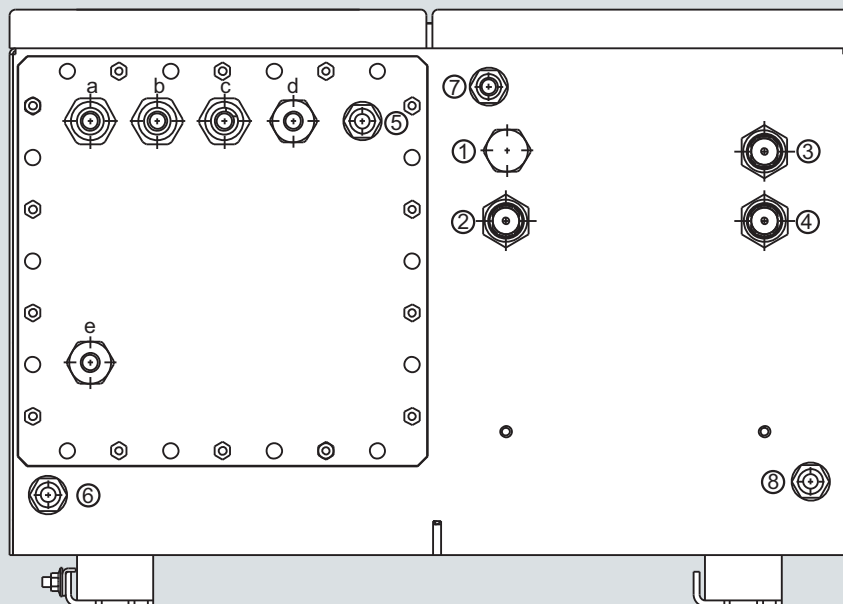

Gas connections

- | | | |
|-----|---|--|
| ① | not used | } Clamping
gland for pipe
Ø 6 mm or ¼" |
| ② | Sample gas inlet | |
| ③ | Reference gas inlet | |
| ④ | Sample gas outlet | |
| ⑤-⑧ | Purging gas inlets/outlets stubs Ø 10 mm or 3/8 " | |

Electrical connections

- | | |
|-------|--|
| a - c | Signal cable (Ø 10 ... 14 mm)
(analog + digital): cable gland M20x1.5 |
| d | Interface connection: (Ø 7 ... 12 mm)
cable gland M20x1.5 |
| e | Power supply: (Ø 7 ... 12 mm)
cable gland M20x1.5 |

OXYMAT 6, field unit, gas and electrical connections

Documentation

Selection and ordering data

Operating instructions	Order No.
ULTRAMAT 6 / OXYMAT 6	
Gas analyzer for IR-absorbing gases and oxygen	
• German	C79000-G5200-C143
• English	C79000-G5276-C143
• French	C79000-G5277-C143
• Spanish	C79000-G5278-C143
• Italian	C79000-G5272-C143

Selection and ordering data

Description	7MB2021	7MB2011	7MB2011 Ex	2 years (quantity)	5 years (quantity)	Order No.
Analyzer unit						
O ring (sample cell)	x	x	x	2	4	D) C71121-Z100-A159
O ring (fitting)	x	x	x	1	2	D) C74121-Z100-A6
O-ring (measuring head)	x	x	x	2	4	D) C79121-Z100-A32
Spacer		x	x	-	1	C79451-A3277-B22
Sample chamber, stainless steel, mat. no. 1.4571; non-flow-type compensation branch	x	x	x	-	1	D) C79451-A3277-B535
Sample chamber, tantalum, non-flow-type compensation branch	x	x	x	-	1	C79451-A3277-B536
Sample chamber, stainless steel, mat. no. 1.4571; flow-type compensation branch	x	x	x	-	1	C79451-A3277-B537
Sample chamber, tantalum, flow-type compensation branch	x	x	x	-	1	C79451-A3277-B538
Measuring head, non-flow-type compensation branch	x	x	x	1	1	C79451-A3460-B525
Measuring head, flow-type compensation branch	x	x	x	1	1	C79451-A3460-B526
Magnetic field connection plate	x	x	x	-	1	C) C79451-A3474-B606
Temperature sensor		x	x	-	1	C79451-A3480-B25
Heating cartridge		x	x	-	1	W75083-A1004-F120
Sample gas path						
Pressure switch (sample gas)	x			1	2	C79302-Z1210-A2
Flowmeter	x			1	2	C79402-Z560-T1
Restrictor, stainless steel, mat. no. 1.4571; hose gas path	x			2	2	C79451-A3480-C10
Restrictor, titanium, pipe gas path	x	x	x	2	2	C79451-A3480-C37
Reference gas path, 3000 hPa	x	x	x	1	1	C79451-A3480-D518
Capillary, 100 hPa, connection set	x	x	x	1	1	C79451-A3480-D519
Restrictor, stainless steel, mat. no. 1.4571; pipe gas path	x	x	x	1	1	C79451-A3520-C5
Electronics						
Temperature controller - electronics, 230 V AC		x	x	-	1	A5E00118527
Temperature controller - electronics, 115 V AC		x	x	-	1	A5E00118530
Fuse (device fuse) T 0.125 A/250 V			x	1	2	A5E00061505
Front plate with keyboard	x			1	1	C79165-A3042-B505
Motherboard, with firmware: see spare parts list	x	x	x	-	1	
Adapter plate, LCD/keyboard	x	x		1	1	C79451-A3474-B605
LC display	x	x		1	1	W75025-B5001-B1
Connector filter	x	x	x	-	1	F) W75041-E5602-K2
Temperature fuse (heated version only)		x		-	1	W75054-T1001-A150
Fuse, T 0.63 A/250 V	x	x	x	2	3	W79054-L1010-T630
Fuse, T 1 A/250 V	x	x	x	2	3	W79054-L1011-T100
Fuse, T 2.5 A/250 V		x	x	2	3	D) W79054-L1011-T250

C) Subject to export regulations AL: N, ECCN: EAR99

D) Subject to export regulations AL: 91999, ECCN: N

F) Subject to export regulations AL: N, ECCN: EAR99H

If the OXYMAT 6 was supplied with a specially cleaned gas path for high oxygen context ("Clean for O₂ service"), please ensure that you specify this when ordering spare parts. This is the only way to guarantee that the gas path will continue to comply with the special requirements for this version.