



IN USA, INC.
87 Crescent Road • Needham, MA 02494 USA
Toll Free (1)-800-798-4029
Tel: (1)-781-444-2929 • FAX: (1)-781-444-9229
Website: www.inusacorp.com

AET-030

Portable Ozone Spot Checker



Ideal for Locating and Repairing Ozone Leaks

Applications:

- For spot checking and locating leaks for service and maintenance personnel
- To ensure ozone levels are below OSHA limits in and around ozone processes
- To measure ozone concentration levels in food storage rooms and other applications

Features:

- Microprocessor based
- Highly ozone specific, thin film semiconductor sensor
- Auto ranging 0-1 ppm, 0-10 ppm
- Calibration traceable to NIST
- Frequent recalibration not required
- Built-in sampling pump
- Data logging via analog output
- Peak hold to record highest value optional
- Visual alarm
- Audible alarm optional
- Light weight and compact
- Battery operated, AA type
- Teflon® Filter housing and filter element included

Specifications **AET-030**

Principle of Operation

A new, state of the art thin film semiconductor sensor was developed for the AET-030 ozone detectors. The sensor is composed of an alumina substrate sandwiched between a thin film platinum heater and a thin film platinum electrode. This electrode is coated with a thin film semiconductor. The coating is accomplished via vapor deposition.

The semiconductor film is kept at high temperature by the heater and its resistance will vary substantially in the presence of ozone due to decomposition and absorption of the gas. This change in resistance is measured and the corresponding change in voltage is linear with ozone concentration.

The basic circuit diagram for the sensor is shown on the right.

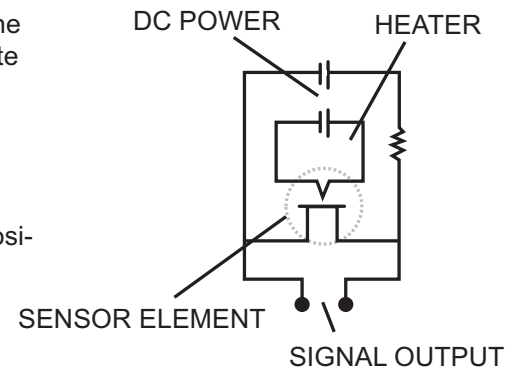

Specifications

Measuring Principle	Thin film semiconductor specially doped to be ozone selective and stable
Measurement Ranges	0.01 - 10 PPMV
Precision/Repeatability	±0.03 PPMV between 0 and 0.5 PPMV; ± 30% range 0.5 PPMV to 10 PPMV
Resolution	0.01 PPMV from 0-1 PPMV; 0.5 PPMV from 1-10 PPMV
Zero Drift	0 with built-in auto-zero function
Linearity	Better than 95% between 0 and 1 PPMV
Calibrated Standard	Traceable to NIST
Ozone Concentration Units	PPMV
Diagnostic Features	Continuous internal diagnostics with error messages
Response Time	1 minute (approx) to 70% of value, 3 minutes (approx) to 90% value
Sample Flow Rate and Control	0.3 l/min (approx) via internal micro-pump
Readout	4 digit LCD display
Alarms	Optional alarm (audible and visual)
Analog Outputs	0-1 VDC corresponding to 0-1 PPMV
Configuration and Weight	Hand held with plastic carrying case, approximate weight 1 lb/500g
Dimensions (W x H x D)	3.3" x 7.5" x 1.5" (84 x 190 x 40 mm)
Power Source	4 AA batteries or via standard AC adaptor
Environmental Operating Conditions	Temperature 1-32° C, humidity 10-80% RH
Sample Connections	1/8" fitting through standard Teflon® particulate filter

Specifications subject to change without notice

Ozone instrumentation for every application						
	Generator Output	Safety/Leak Detection	Tool Leak Detection	Stack & Environment	Dissolved Ozone	Spot Checking
Model dFFOZ-TR					●	
Model dFFOZ					●	
Model W1 Series					●	
Model gFFOZ	●					
Model Mini-HiCon	●					
Model H1 Series	●					
Model L2RM			●			
Model IN-2000		●	●	●		
Model AET-030						●



IN USA, INC. - 87 Crescent Road - Needham, MA 02494 USA - Toll Free (1)-800-798-4029
Tel: (1)-781-444-2929 FAX: (1)-781-444-9229 Website: www.inusacorp.com