

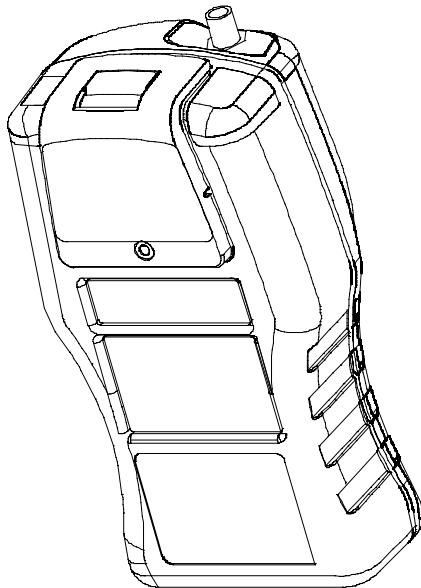

OrionTM Multigas Detector

Operating Manual



In North America, to contact your nearest stocking location, dial toll-free 1-800-MSA-2222. To contact MSA International, dial 1-412-967-3354 or 1-800-MSA-7777.

© MINE SAFETY APPLIANCES COMPANY 2001 - All Rights Reserved

Manufactured by
MSA INSTRUMENT DIVISION
P.O. Box 427, Pittsburgh, Pennsylvania 15230

WARNING

THIS MANUAL MUST BE CAREFULLY READ BY ALL INDIVIDUALS WHO HAVE OR WILL HAVE THE RESPONSIBILITY FOR USING OR SERVICING THE PRODUCT. Like any piece of complex equipment, this instrument will perform as designed only if it is used and serviced in accordance with the manufacturer's instructions. OTHERWISE IT COULD FAIL TO PERFORM AS DESIGNED AND PERSONS WHO RELY ON THIS PRODUCT FOR THEIR SAFETY COULD SUSTAIN SEVERE PERSONAL INJURY OR DEATH.

The warranties made by Mine Safety Appliances Company with respect to the product are voided if the product is not used and serviced in accordance with the instructions in this manual. Please protect yourself and others by following them. We encourage our customers to write or call regarding this equipment prior to use or for any additional information relative to use or repairs.

CAUTION

For safety reasons, this equipment must be operated by qualified personnel only. Read and understand the instruction manual completely before operating.

Table of Contents

Chapter 1	
Instrument Safety and Certifications	1-1
▲ WARNING	1-1
Safety Limitations and Precautions	1-2
Date of Instrument Manufacture	1-4
Certifications	1-4
Electronic Interference	1-4
Chapter 2	
Quick Start	2-1
Figure 2-1. Understanding the Display	2-1
Turning ON the Orion Multigas Detector.	2-2
Figure 2-2. Flow Diagram	2-2
Moving Through the Orion Multigas Detector Pages	2-3
Figure 2-3. Orion Buttons	2-3
Turning OFF the Orion Multigas Detector	2-4
Chapter 3	
Using the Orion Multigas Detector	3-1
Turning ON the Orion Multigas Detector.	3-1
Installing the Battery Pack (FIGURE 3-1)	3-1
Figure 3-1. Battery Pack Installation	3-1
Fresh Air Set Up Option	3-2
▲ WARNING	3-2
Heartbeat Indicator (see FIGURE 3-2)	3-3
Battery Life Indicator (see FIGURE 3-2)	3-3
Battery Warning	3-3
Figure 3-2. Battery and Heartbeat Indicators	3-3
Battery Shutdown	3-4

▲ WARNING.....	3-4
▲ CAUTION	3-5
▲ WARNING.....	3-5
Verifying Pump Operation	3-5
▲ WARNING.....	3-6
▲ WARNING.....	3-6
Figure 3-3. Pump Alarm on the Display	3-6
To Clear an Alarm	3-7
Calibration Check	3-7
Diffusion Instrument	3-7
Figure 3-4. Instrument with Calibration Cap Installed	3-7
Pumped Instrument (FIGURE 3-5)	3-8
Figure 3-5. Pumped Instrument with Calibration Tubing ...	3-8
Measuring Gas Concentrations	3-9
Combustible gases (% LEL) (FIGURE 3-6)	3-9
Figure 3-6. Instrument in LEL Alarm	3-9
▲ WARNING.....	3-10
Oxygen Measurements (% O ₂) (FIGURE 3-7)	3-10
Figure 3-7. Instrument in Oxygen Alarm	3-10
▲ WARNING.....	3-11
Toxic Gas Measurements (FIGURE 3-8).....	3-11
▲ WARNING.....	3-11
Figure 3-8. Instrument in Toxic Gas Alarm	3-11
Viewing Optional Displays (see FIGURE 3-9).....	3-12
Figure 3-9. Flow Diagram	3-12
Peak Readings (PEAK) (FIGURE 3-10).....	3-13
Minimum Readings (MIN) (FIGURE 3-11)	3-13
Figure 3-10. PEAK Readings on the Display	3-13
Figure 3-11. MIN Reading on Display	3-13
Short Term Exposure Limits (STEL) (FIGURE 3-12).....	3-14
Figure 3-12. Exposure Page with STEL Alarm	3-14
▲ WARNING.....	3-15

Time Weighted Average (TWA) (FIGURE 3-13)..... 3-15
 Figure 3-13. Exposure Page with TWA Alarm 3-15
 ▲ WARNING 3-16
 Time Display (FIGURE 3-14) 3-17
 Date Display (FIGURE 3-15)..... 3-17
 Figure 3-14. Time Display 3-17
 Figure 3-15. Date Display 3-17
 Turning OFF the Orion Multigas Detector 3-18

Chapter 4

Setting up the Multigas Detector 4-1

Power Systems 4-1
 Table 4-1. Approximate Battery Run Times (20°C) 4-1
 Table 4-2. Capacity Reductions Expected for Batteries at
 Colder Temperatures 4-1
 Battery Pack Removal (FIGURE 4-1) 4-1
 Battery Charging (NiMH Battery Pack Only) 4-2
 ▲ CAUTION 4-2
 To Charge the Battery Pack (A.C. Charger 10020551)..... 4-2
 Figure 4-1. Removing the Battery 4-2
 To Charge the Battery Pack (Vehicle Charger 10026502) 4-3
 Alkaline Battery Pack 4-3
 Table 4-3. Batteries Approved for use in the Orion
 Alkaline Battery Pack 4-4
 To Replace the Batteries 4-4
 Changing Instrument Settings 4-4
 Table 4-4. Available Instrument Selections and Methods
 for Changing Selections..... 4-5
 Changing Time and Date (Datalog Equipped Instruments Only) ... 4-5
 To Change the Time of Day: 4-5
 To Change the Date:..... 4-5
 Accessing the Instrument Setup Mode (FIGURES 4-2 and 4-3) ... 4-6

To Access the Instrument Set-up Mode:	4-6
Figure 4-2. Instrument Setup Mode (part 1 of 2).....	4-7
Figure 4-3. Instrument Setup Mode (part 2 of 2).....	4-8
When in the Set-up Mode, the Following Options Appear:.....	4-9
▲ WARNING.....	4-9

Chapter 5

Calibration 5-1

Calibrating the Orion Multigas Detector	5-1
Table 5-1. Autocalibration and Required Calibration Cylinders.....	5-1
To Calibrate the Orion Multigas Detector (FIGURE 5-1):.....	5-1
Figure 5-1. Calibration Flow Chart	5-2
Figure 5-2. Zero Flag	5-3
Figure 5-3. CAL Flag	5-3
Autocalibration Failure	5-4
Figure 5-4. Typical Calibration Setup - for Diffusion with Cal Cap	5-5
Figure 5-5. Typical Calibration Setup - for Pumped Versions	5-5
Accessing the Expanded Tolerance Calibration	5-6

Chapter 6

Warranty, Maintenance and Troubleshooting 6-1

MSA Portable Instrument Warranty	6-1
Cleaning and Periodic Checks	6-2
▲ WARNING.....	6-2
Cleaning and Routine Care	6-3
▲ WARNING.....	6-3
Checking The Pump Inlet Filter.....	6-3
Replacing the Filters.....	6-4
▲ CAUTION	6-4

Dust Filter (see FIGURE 8-2 and TABLE 8-2)	6-4
Water Filter	6-4
Internal "Firewall" Filter (see FIGURES 8-1 and 8-2 and TABLE 8-2)	6-4
▲ CAUTION	6-5
▲ WARNING	6-5
Probe Filter	6-6
Storage	6-6
▲ WARNING	6-6
Figure 6-1. Replacing the Probe Filter	6-6
Shipment	6-7
Troubleshooting	6-7
Table 6-1. Troubleshooting Guidelines	6-8
Repair Procedures	6-9
Battery Pack Replacement	6-9
Remove the Battery Pack	6-9
Replace the Battery Pack	6-9
Sensor Replacement	6-9
▲ WARNING	6-10
Main Electronics Board Replacement	6-10
▲ CAUTION	6-10
▲ CAUTION	6-10
▲ WARNING	6-11
Display Assembly Replacement	6-12
▲ CAUTION	6-12
▲ CAUTION	6-12
▲ WARNING	6-13
Horn Assembly Replacement	6-14
Pump Replacement	6-14
▲ CAUTION	6-14
▲ CAUTION	6-14
▲ WARNING	6-15

Chapter 7	
Performance Specifications	7-1
Table 7-1. Certifications	7-1
Table 7-2. Instrument Specifications	7-2
Table 7-3. COMBUSTIBLE GAS - Typical Performance Specifications	7-3
Table 7-4. COMBUSTIBLE GAS - Cross Reference Factors for Orion General-Purpose Calibration Using Calibration Cylinder (P/N 478191), (P/N 478192), (P/N 804769), or (P/N 804770) Set to 58% LEL	7-3
Environment and Oxygen Sensor Readings	7-4
Pressure Changes	7-4
Humidity Changes	7-4
Temperature Changes	7-4
Table 7-5. OXYGEN - Typical Performance Specifications	7-4
Table 7-6. CARBON MONOXIDE (appropriate models only) - Typical Performance Specifications	7-5
Table 7-7. CARBON MONOXIDE - Cross Reference Factors for Orion Calibration Using Calibration Cylinder (P/N 478191) or (P/N 804770)	7-5
Table 7-8. HYDROGEN SULFIDE (appropriate models only) - Typical Performance Specifications	7-6
Table 7-9. HYDROGEN SULFIDE - Cross Reference Factors for Orion Calibration Using Calibration Cylinder (P/N 804769) or (P/N 804770) Set to 10 ppm H ₂ S	7-6
Chapter 8	
Replacement and Accessory Parts	8-1
Table 8-1. Accessory Parts List	8-1
Table 8-2. Replacement Parts List	8-2
Figure 8-1. Replacement Parts (see Table 8-2)	8-3
Figure 8-2. Replacement Parts (see Table 8-2)	8-4

Chapter 1

Instrument Safety and Certifications

The Orion™ Multigas Detector is for use by trained and qualified personnel. It is designed to be used when performing a hazard assessment to:

- Assess potential worker exposure to combustible and toxic gases and vapors
- Determine the appropriate gas and vapor monitoring needed for a workplace.

The Orion Multigas Detector can be equipped to detect:

- Combustible gases and certain combustible vapors
- Oxygen-deficient or oxygen-rich atmospheres
- Specific toxic gases for which a sensor is installed.

WARNING

- Read and follow all instructions carefully.
- Check calibration before each day's use and adjust if necessary.
- Check calibration more frequently if exposed to silicone, silicates, lead-containing compounds, hydrogen sulfide, or high contaminant levels.
- Recheck calibration if unit is subjected to physical shock.
- Check pump (if used) for proper operation before each days use.
- Use only to detect gases/vapors for which a sensor is installed.
- Do not use to detect combustible dusts or mists.
- Make sure adequate oxygen is present.
- Do not block sensors.
- Do not place end of sampling line in liquids.
- Wait for accurate reading; response times vary, based on gas/vapor and length of sampling line.

- Have a trained and qualified person interpret instrument readings.
- Do not replace alkaline cells in a combustible atmosphere.
- Do not recharge NiMH battery packs in a combustible atmosphere.
- Do not alter or modify instrument.

INCORRECT USE CAN CAUSE SERIOUS PERSONAL INJURY OR DEATH.

Safety Limitations and Precautions

Carefully review the following safety limitations and precautions before placing this instrument in service:

- The Orion Multigas Detector is designed to:
 - Detect gases and vapors in air only
 - Detect only specified toxic gases for which a sensor is installed.
- Perform the following checks before each day's use to verify proper instrument operation:
 - Calibration check (see Calibration Check section). Adjust calibration if the readings are not within the specified limits.
 - Check pump (if used) for proper operation (see "Verifying Pump Operation" section). Have pump serviced if necessary.
- Check calibration more frequently if the unit is subjected to physical shock or high levels of contaminants. Also, check calibration more frequently if the tested atmosphere contains the following materials, which may desensitize the combustible gas sensor and reduce its readings:
 - Organic silicones
 - Silicates
 - Lead-containing compounds
 - Hydrogen sulfide exposures over 200 ppm or exposures over 50 ppm for one minute.
- The minimum concentration of a combustible gas in air that can ignite is defined as the Lower Explosive Limit (LEL). A combustible gas reading of "100" indicates the atmosphere is

above 100% LEL and an explosion hazard exists. In such cases, the instrument LockAlarm feature activates. Move away from contaminated area immediately.

- Do not use the Orion Multigas Detector to test for combustible or toxic gases in the following atmospheres as this may result in erroneous readings:
 - Oxygen-deficient or oxygen-rich atmospheres
 - Reducing atmospheres
 - Furnace stacks
 - Inert environments
 - Atmospheres containing combustible airborne mists or dusts.
- Do not use the Orion Multigas Detector to test for combustible gases in atmospheres containing vapors from liquids with a high flash point (above 100^oF) as this may result in erroneously low readings.
- Do not block sensor openings as this may cause inaccurate readings. Do not press on the face of the sensors, as this may damage them and cause erroneous readings. Do not use compressed air to clean the sensor holes, as the pressure may damage the sensors.
- Allow sufficient time for unit to display accurate reading. Response times vary based on the type of sensor being utilized (see "Performance Specifications" section of manual). Additionally, when using a sampling pump, allow a minimum of 0.7 seconds per foot of sample line to allow the sample to be drawn through to the sensors.
- Keep the probe tip above liquid surfaces; otherwise, liquid may enter the system and block the sample flow, causing inaccurate readings and/or internal damage.
- All instrument readings and information must be interpreted by someone trained and qualified in interpreting instrument readings in relation to the specific environment, industrial practice and exposure limitations.
- Replace alkaline cells or recharge NiMH battery-pack in non-hazardous area only. Use only battery chargers listed in this manual; other chargers may damage the battery pack and the unit. Dispose of batteries in accordance with local health and safety regulations.

- Do not alter this instrument or make any repairs beyond those specified in this manual. Only MSA-authorized personnel may repair this unit; otherwise, damage may result.

Date of Instrument Manufacture

The date of manufacture of your Orion Multigas Detector is coded into the instrument serial number.

- The last three digits represent the month (the letter) and the year (the two-digit number).
- The letter corresponds to the month starting with A for January, B for February, etc.

Certifications

Tests completed by MSA verify that the Orion Multigas Detector meets applicable industry and government standards as of the date of manufacture.

Electronic Interference

- This instrument generates, uses, and can radiate radio frequency energy. Operation of this instrument may cause interference, in which case, the user may be required to correct.
- This device is test equipment and is not subject to FCC technical regulations. However, it has been tested and found to comply with the limits for a Class A digital device specified in Part 15 of the FCC regulations.
- This digital apparatus does not exceed the Class A limits for radio noise emissions from digital apparatus set out in the Radio Interference Regulations of the CRTC.
- There is no guarantee that interference will not occur. If this instrument is determined to cause interference to radio or television reception, try the following corrective measures:
 - Reorient or relocate the receiving antenna
 - Increase separation between the instrument and the radio/TV receiver
 - Consult an experienced radio/TV technician for help.

Chapter 2 Quick Start

It is your responsibility to know how to use the Orion Multigas Detector. When used properly, the Orion Multigas Detector will alert you to the presence of combustible gases and vapors and to atmospheres that are rich or deficient in oxygen. It will also alert you to the presence of carbon monoxide and hydrogen sulfide, if it is equipped with sensors for those gases. These conditions are displayed clearly and simultaneously on the face of the instrument. See FIGURE 2-1 for an explanation of the flags, numbers and button operation of the Orion Multigas Detector.

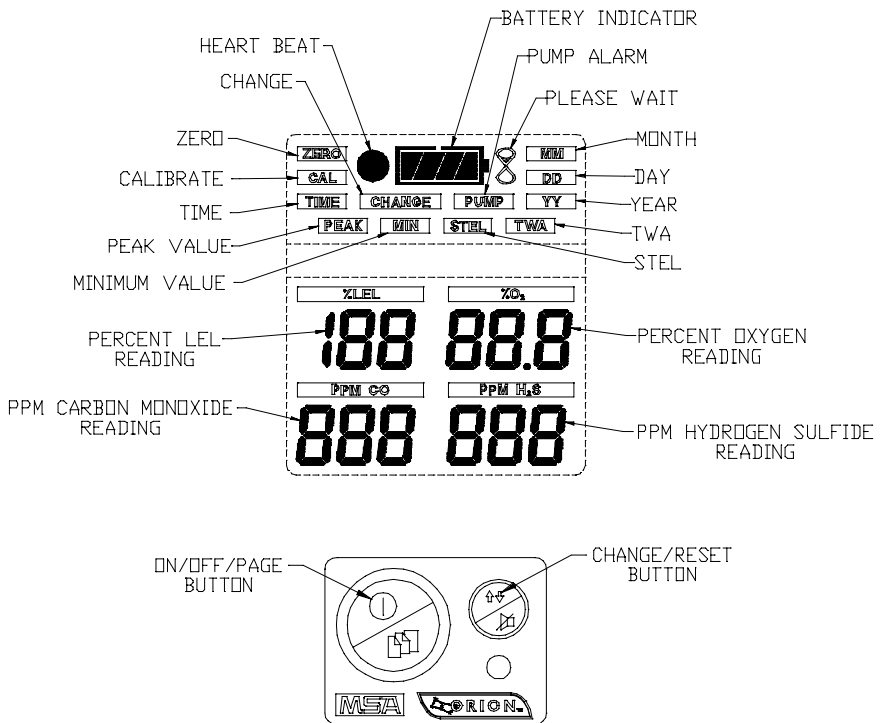

Figure 2-1. Understanding the Display

Turning ON the Orion Multigas Detector

To turn ON the Orion Multigas Detector:

- Install the battery pack or
- If the battery pack is already installed, push the ON-OFF/PAGE button.

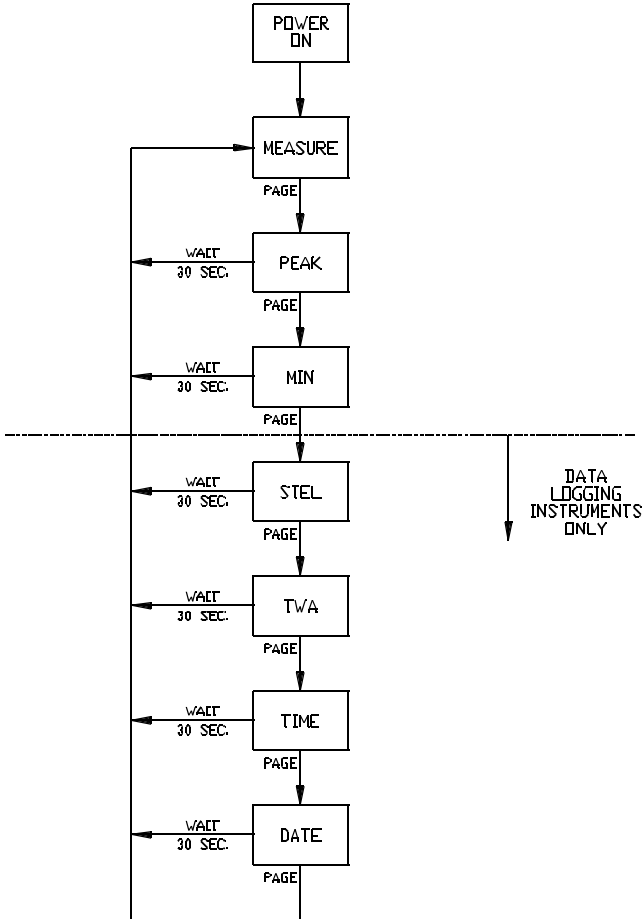

Figure 2-2. Flow Diagram

The instrument then performs a Self-test where the:

- display check occurs (every segment on the display momentarily illuminates)
- audible alarm sounds
- alarm lights illuminate
- display backlight illuminates.

Once the Self-test is complete, the instrument enters the Measure mode and is ready for use.

Moving Through the Orion Multigas Detector Pages

FIGURE 2-2 is a flow diagram showing the operation of the instrument. Note that the STEL, TWA, TIME and DATE pages will appear only if the Orion Multigas Detector is equipped with the optional datalogging package. To access instrument features and informational pages:

- Push the ON-OFF/PAGE button (FIGURE 2-3).

The Pages appear in the following order:

- **Peak**
Shows peak value recorded since last instrument turn-ON
- **Min**
Shows minimum value recorded since last instrument turn-ON for the oxygen sensor only
- **STEL** (Datalogging instrument only)
Shows Short Term Exposure Limit for installed toxic gas sensors

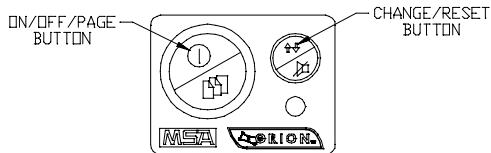

Figure 2-3. Orion Buttons

- **TWA** (Datalogging instrument only)
Shows Time Weighted Average for installed toxic gas sensors
- **Time** (Datalogging instrument only)
Shows time of day in a 24-hour format
- **Date** (Datalogging instrument only)
Shows current date in a Month/Day/Year format.

To return instrument to the Measure page:

- Push the ON-OFF/PAGE button again
- The instrument will automatically return to the Measure page after a delay of 30 seconds on any page.

Turning OFF the Orion Multigas Detector

To turn OFF the Orion Multigas Detector:

- Push and hold the ON-OFF/PAGE button for five seconds.
 - Hourglass displays to indicate instrument turn-OFF.

Chapter 3

Using the Orion Multigas Detector

Turning ON the Orion Multigas Detector

Installing the Battery Pack (FIGURE 3-1)

1. Slide battery pack toward the top of the instrument.
2. Swing battery pack up and into the body of the instrument.
3. Secure battery pack by installing the two screws in the bottom two corners of the battery pack and instrument. The screws must be snug to ensure that the battery pack properly seals to the instrument. Do not over-tighten.
4. Once battery pack is installed, the Orion Multigas Detector will turn ON.

The instrument now performs the following Self-test where the:

- Display check occurs (every segment on the display momentarily illuminates)
- Audible alarm sounds
- Alarm lights illuminate
- Display backlight illuminates
- Internal instrument diagnostic occurs (any detected internal errors appear on the display).

When Self-test ends:

- Instrument enters the Measure mode
- Gas concentrations appear on the display.

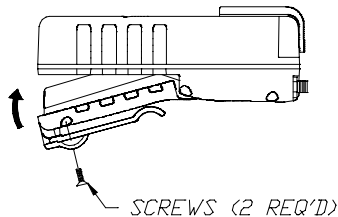

Figure 3-1. Battery Pack Installation

Fresh Air Set Up Option

(for automatic zero adjustment of the Orion Multigas Detector sensors)

NOTE: The Fresh Air Setup (FAS) has limits. If a hazardous level of gas is present, the Orion Multigas Detector ignores the FAS command and goes into alarm.

WARNING

Do not activate the Fresh Air Setup unless you are certain you are in fresh, uncontaminated air; otherwise, inaccurate readings can occur which can falsely indicate that a hazardous atmosphere is safe. If you have any doubts as to the quality of the surrounding air, do not use the Fresh Air Setup feature. Do not use the Fresh Air Setup as a substitute for daily calibration checks. The calibration check is required to verify span accuracy. Failure to follow this warning can result in serious personal injury or death.

Persons responsible for the use of the Orion Multigas Detector must determine whether or not the Fresh Air Setup option should be used. The user's abilities, training and normal work practices must be considered when making this decision.

1. Turn ON the Orion Multigas Detector.
 - Once the instrument self check is complete, the ZERO flag flashes for 10 seconds.
2. To perform a Fresh Air Setup, push the ON/OFF-PAGE button while the Zero flag is flashing.
3. To immediately skip the FAS, push the CHANGE/RESET button.
 - If no buttons are pushed, the FAS automatically stops flashing after the 10 seconds have expired.

Heartbeat Indicator (see FIGURE 3-2)

- The Heartbeat Indicator flashes once every 30 seconds to notify the user the instrument is ON and operating.

Battery Life Indicator (see FIGURE 3-2)

- The battery condition icon continuously displays in the upper portion of the screen, regardless of the selected page.
- As the battery charge dissipates, segments of the battery icon go blank until only the outline of the battery icon remains.

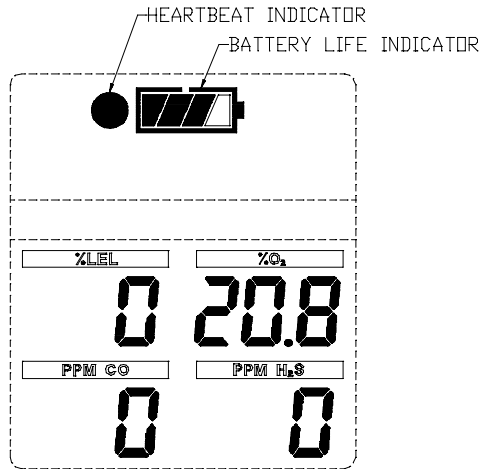

Figure 3-2. Battery and Heartbeat Indicators

Battery Warning

- A Battery Warning indicates that a nominal 20 minutes of operation remain before instrument batteries are completely depleted.

NOTE: Duration of remaining instrument operation during Battery Warning depends on:

- Ambient temperatures
(The battery warning is likely to be shorter in colder temperatures, particularly with alkaline batteries)
- Whether the battery warning is reset (it comes ON again every five minutes).
- When the Orion Multigas Detector goes into Battery Warning:
 - Battery Life indicator flashes
 - Alarm sounds
 - Alarm lights flash.

- To silence the Battery Warning, push the CHANGE/RESET button.
- Once the battery warning has been silenced, the alarm will re-activate in approximately five minutes.
- The Orion Multigas Detector continues to operate until the instrument is turned OFF or battery shutdown occurs.

Battery Shutdown

When the batteries can no longer operate the instrument, the instrument goes into Battery Shutdown mode:

- Battery Indicator remains ON
- Alarm sounds continuously
- Alarm lights flash
- No other pages can be viewed
- After approximately five minutes, the instrument automatically turns OFF.

WARNING

When Battery Shutdown condition sounds, stop using the instrument; it can no longer alert you of potential hazards since it does not have enough power to operate properly. You must:

1. Leave the area immediately.
2. Turn OFF the instrument if it is ON.
3. Report to the person responsible for maintenance.
4. Replace or recharge the battery pack.

Failure to follow this procedure, could result in serious personal injury or death.

For Alkaline Battery packs, replace batteries when the "Battery Low" or "Battery Shutdown" alarms occur. When replacing alkaline batteries, replace ALL batteries with fresh ones at the same time. Do not mix new and partially-discharged batteries. If the batteries are improperly replaced or improperly mixed, the "Battery Low" and "Battery Shutdown" alarms may fail to function, which could result in serious personal injury or death.

Do not use rechargeable batteries in Alkaline Battery Packs. The Alkaline battery warning and alarm setpoints are not optimized for rechargeable batteries. The low battery warning and alarm could occur too quickly to be noticed. Using rechargeable batteries in the Alkaline battery pack could result in serious personal injury or death.

NOTE: The instrument recognizes the type of installed battery pack (rechargeable NiMH or alkaline) and automatically adjusts the low battery warning and alarm setpoints.

⚠ CAUTION

During "Battery Low" condition, prepare to exit the work area since the instrument could go into "Battery Shutdown" at any time, resulting in loss of sensor function. Depending on the age of the batteries, ambient temperature and other conditions, the instrument "Battery Low" and "Battery Shutdown" times could be shorter than anticipated.

⚠ WARNING

Recharge or replace the batteries when the "Battery Low" or "Battery Shutdown" conditions occur.

Do not reuse a NiMH battery without recharging, even if the battery regains some charge after a period of non-use.

Verifying Pump Operation

This section applies only to Orion Multigas Detectors supplied with the integral PulseCheck[®] Sampling Pump.

1. Turn ON the Orion Multigas Detector.
 - The pump motor starts fast and then slows down as the instrument adjusts the power to run the pump.
 - The pump indicator will flash until the proper flow rate is obtained.

2. Once gas readings are displayed, plug the free end of the sampling line or probe.
 - The pump motor shuts down and an alarm sounds (FIGURE 3-3)
 - The pump indicator will illuminate
 - The readings on the display may change.
3. When the pump inlet, sample line or probe is blocked, the pump alarm must activate. If the alarm does not activate:
 - a. Check the pump, sample line, and probe for leaks.
 - b. Once the leak is fixed, recheck the pump alarm by blocking the flow.
4. Check the pump before each day's use.

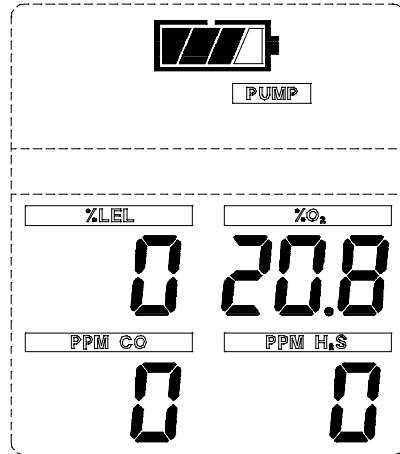

Figure 3-3. Pump Alarm on the Display

⚠ WARNING

Do not use the pump, sample line, or probe unless the pump alarm activates when the flow is blocked. Lack of an alarm is an indication that a sample may not be drawn to the sensors, which could cause inaccurate readings. Failure to follow the above can result in serious personal injury or death.

⚠ WARNING

Never let the end of the sampling line touch or go under any liquid surface. If liquid is sucked into the instrument, readings will be inaccurate and the instrument could be damaged. We recommend the use of an MSA Sample Probe (P/N 497600, 800332, 800333, or equivalent) containing a special membrane filter, permeable to gas but impermeable to water, to prevent such an occurrence.

5. Press the CHANGE/RESET button to reset the alarm and restart the pump.

During operation, a pump alarm may occur when the:

- Flow system is blocked
- Pump is inoperative
- Sample lines are attached or removed.

To Clear an Alarm

1. Correct any flow blockage.
2. Press the CHANGE/RESET button.
 - The Pump will now restart.

NOTE: When the instrument is in a gas alarm, the pump alarm may not display until gas alarm is cleared.

Calibration Check

The calibration check is simple and should only take about one minute. Perform this calibration check before each day's use.

1. Turn ON the Orion Multigas Detector in clean, fresh air.
2. Verify that readings indicate no gas is present.

Diffusion Instrument

If your Orion Multigas Detector is NOT equipped with an optional built-in sampling pump:

1. Attach calibration cap to the Orion Multigas Detector, orienting the inlet fitting toward the display (FIGURE 3-4).
2. Attach regulator (supplied with calibration kit) to the cylinder.

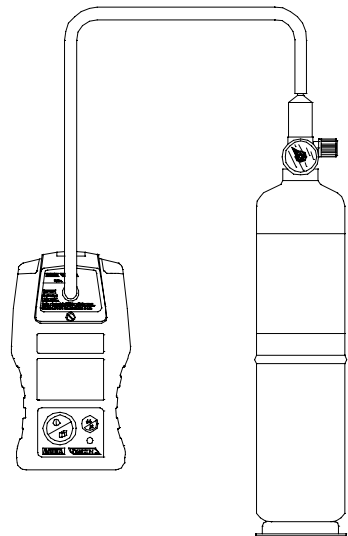

Figure 3-4. Instrument with Calibration Cap Installed

3. Connect tubing (supplied with calibration kit) to the regulator.
4. Attach other end of tubing to the calibration cap.
5. Open the valve on the regulator.
 - The regulator flow rate is 0.25 lpm.
 - The reading on the Orion Multigas Detector display should be within the limits stated on the calibration cylinder or limits determined by your company.
 - If necessary, change cylinder to introduce other calibration gases.
 - If readings are not within these limits, the Orion Multigas Detector requires recalibration. See Chapter 5, "Calibrating the Orion Multigas Detector."

Pumped Instrument (FIGURE 3-5)

If your Orion Multigas Detector is equipped with the optional built-in sampling pump:

1. Attach the regulator (supplied with calibration kit) to the cylinder.
2. Connect the tubing (supplied with calibration kit) to the regulator.
3. Attach the other end of tubing to the Orion pump inlet fitting.
4. Open the regulator valve.
 - The flow rate of the regulator is 0.25 lpm.
 - The reading on the Orion Multigas Detector display should be within the limits stated on the calibration cylinder or limits determined by your company.
 - If necessary, change the cylinder to introduce other calibration gases.

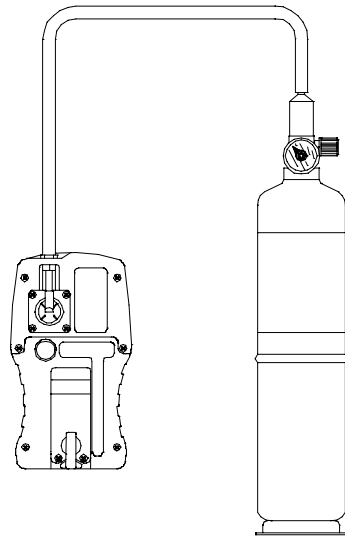

Figure 3-5. Pumped Instrument with Calibration Tubing

Measuring Gas Concentrations

Combustible gases (% LEL) (FIGURE 3-6)

The Orion Multigas Detector can be equipped to detect combustible gases in the atmosphere.

- Alarms sound when concentrations reach:
 - Alarm Setpoint or
 - 100% LEL (Lower Explosive Limit).
- When the combustible gas indication reaches the Alarm Setpoint:
 - Alarm sounds
 - Alarm lights flash
 - % LEL label above the concentration flashes.

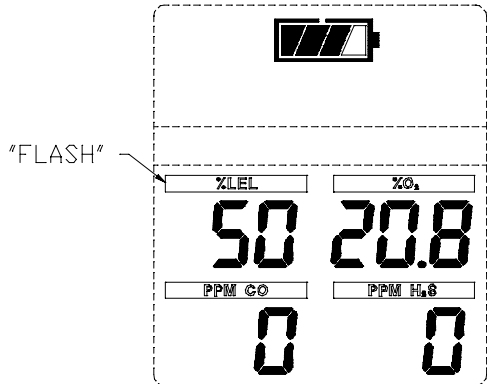

Figure 3-6. Instrument in LEL Alarm

- To silence the alarm, press the CHANGE/RESET button.

NOTE: The alarm will stay silent if the alarm condition has cleared.

- When the combustible gas indication reaches 100% LEL, the LockAlarm™ circuit locks the combustible gas reading and alarm and:
 - Alarm sounds
 - Alarm lights flash
 - 100 appears on the display and flashes.
- This alarm cannot be reset with the CHANGE/RESET button.

⚠ WARNING

If the 100% LEL alarm condition is reached, you may be in a life-threatening situation; there is enough gas in the atmosphere for an explosion to occur. In addition, any rapid up-scale reading followed by a declining or erratic reading can also be an indication that there is enough gas for an explosion. If either of these indications occur, leave and move away from the contaminated area immediately. Failure to follow this warning can result in serious personal injury or death.

- After moving to a safe, fresh-air environment, reset the alarm by turning OFF the instrument and turning it ON again.

Oxygen Measurements (% O₂) (FIGURE 3-7)

The Orion Multigas Detector can be equipped to detect the amount of oxygen in the atmosphere.

- Two conditions trigger the alarm:
 - Too little oxygen (deficient)
 - Too much oxygen (enriched).
- When the alarm setpoint is reached for either of the above:
 - Alarm sounds
 - Alarm lights flash
 - % O₂ label above the concentration flashes.

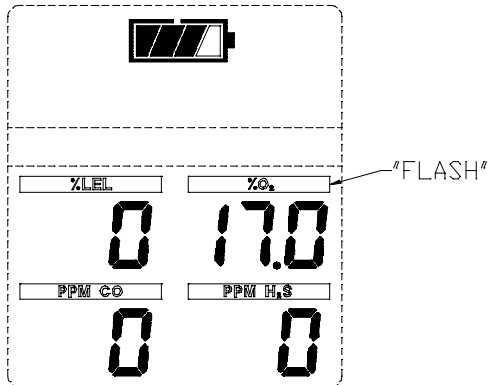

Figure 3-7. Instrument in Oxygen Alarm

⚠ WARNING

If the Oxygen alarm condition is reached while using the instrument as a personal or area monitor, leave the area immediately; the ambient condition has reached a preset alarm level. If using the instrument as an inspection device, do not enter the area without proper protection. Failure to follow this warning will cause exposure to a hazardous environment which can result in serious personal injury or death.

Toxic Gas Measurements (FIGURE 3-8)

- The Orion Multigas Detector can be equipped to detect:
 - Carbon Monoxide (CO) and/or
 - Hydrogen Sulfide (H₂S) in the atmosphere.
- When the alarm setpoint is reached for Carbon Monoxide (CO) and/or Hydrogen Sulfide (H₂S):

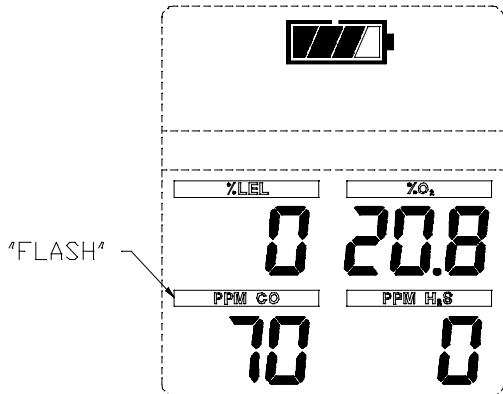

Figure 3-8. Instrument in Toxic Gas Alarm

- Alarm Sounds
- Alarm Lights flash
- PPM CO or PPM H₂S label above the concentration flashes.

⚠ WARNING

If the Toxic Gas alarm condition is reached while using the instrument as a personal or area monitor, leave the area immediately; the ambient condition has reached a preset alarm level. If using the instrument as an inspection device, do not enter the area without proper protection. Failure to follow this warning will cause over-exposure to toxic gases, which can result in serious personal injury or death.

Viewing Optional Displays (see FIGURE 3-9)

The diagram shown in FIGURE 3-9 describes the flow for optional displays.

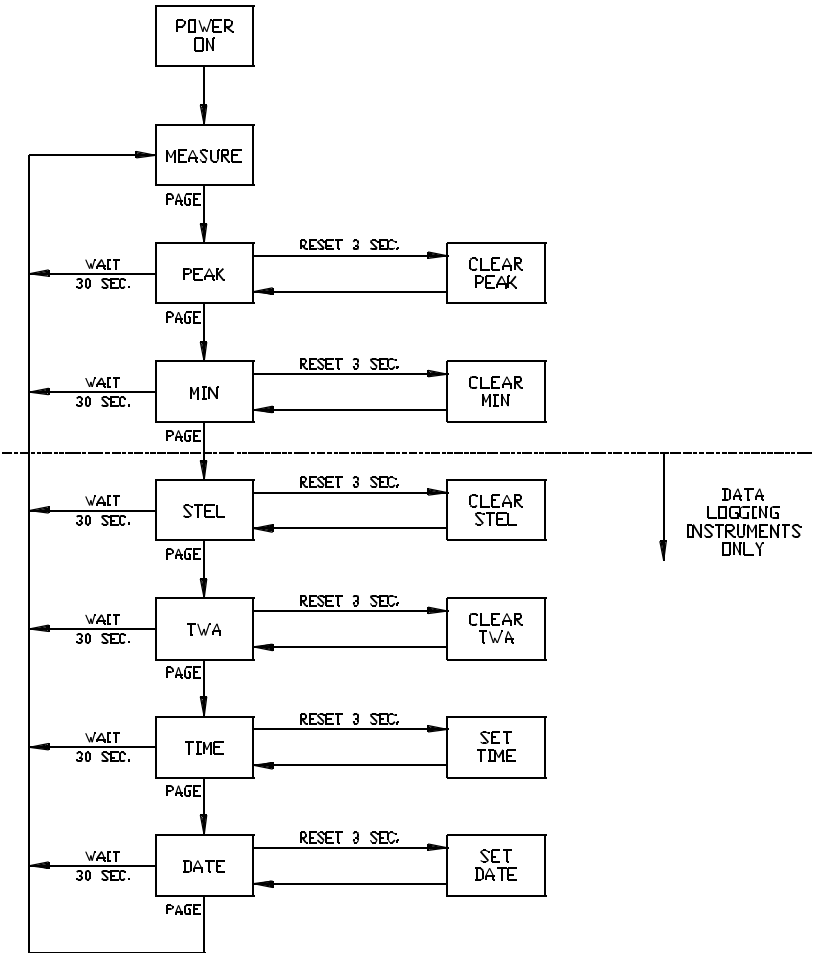

Figure 3-9. Flow Diagram

NOTE: The following Display pages appear only if they are enabled.

Press the ON-OFF/PAGE button to move to:

Peak Readings (PEAK) (FIGURE 3-10)

- The PEAK flag appears in the upper portion of the display to show the highest levels of gas recorded by the Orion Multigas Detector since:
 - Turn-ON or
 - Peak readings were reset.
- To Reset the Peak Readings:
 1. Access the Peak page.
 2. Push and hold the CHANGE/RESET button until the PEAK flag flashes.
 3. Push the ON-OFF/PAGE button to reset the Peak.

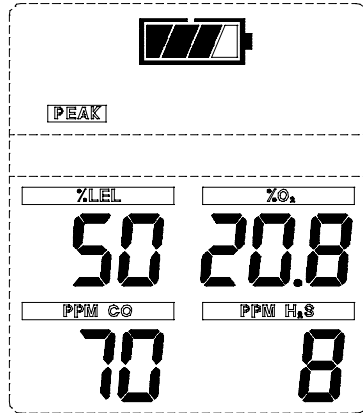

Figure 3-10. PEAK Readings on the Display

Minimum Readings (MIN) (FIGURE 3-11)

- This page shows the lowest level of oxygen recorded by the Orion Multigas Detector since:
 - Turn-ON or
 - MIN reading was reset.
- The MIN flag appears in the upper portion of the display.

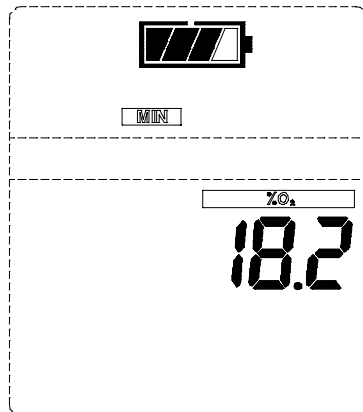

Figure 3-11. MIN Reading on Display

- To reset the MIN Reading:
 1. Access the Min page.
 2. Push and hold the CHANGE/RESET button until the MIN flag flashes.
 3. Push the ON-OFF/PAGE button to reset the MIN.

NOTE: The following pages appear only if the instrument is equipped with the Datalogging option.

Short Term Exposure Limits (STEL) (FIGURE 3-12)

- The STEL flag appear in the upper portion of the display to show the average exposure over a 15-minute period.
- When the amount of gas detected by the Orion Multigas Detector is greater than the STEL limit:
 - Alarm sounds
 - Alarm lights flash
 - The STEL flag flashes.

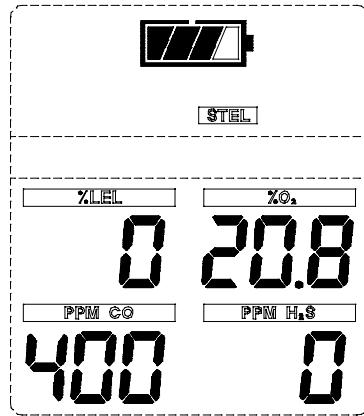

Figure 3-12. Exposure Page with STEL Alarm

To Reset the Alarm:

1. Access the STEL page.
2. Push and hold the CHANGE/RESET button until the STEL flag flashes.
3. Push the ON-OFF/PAGE button to reset the STEL.

The STEL alarm is calculated over a 15-minute exposure. Calculation examples are as follows:

Assume the Orion Multigas Detector has been running for at least 15 minutes.

15-minute exposure of 35 PPM:

$$\frac{(15 \text{ minutes} \times 35 \text{ PPM})}{15 \text{ minutes}} = 35 \text{ PPM}$$

- 10-minute exposure of 35 PPM
5-minute exposure of 5 PPM:

$$\frac{(10 \text{ minutes} \times 35 \text{ PPM}) + (5 \text{ minutes} \times 5 \text{ PPM})}{15 \text{ minutes}} = 25 \text{ PPM}$$

Assume the Orion Multigas Detector was turned on five minutes ago.

- 5-minute exposure of 15 PPM:

$$\frac{(5 \text{ minutes} \times 15 \text{ PPM}) + (10 \text{ minutes} \times 0 \text{ PPM})}{15 \text{ minutes}} = 5 \text{ PPM}$$

⚠ WARNING

If the STEL alarm condition is reached while using the instrument as a personal or area monitor, leave the contaminated area immediately; the ambient gas concentration has reached the preset STEL alarm level. Failure to follow this warning will cause over-exposure to toxic gases, which can result in serious personal injury or death.

Time Weighted Average (TWA) (FIGURE 3-13)

- The TWA flag will appear in the upper portion of the display to show the average exposure since the TWA reading was reset.
- When the amount of gas detected by the Orion Multigas Detector is greater than the eight-hour TWA limit:
 - Alarm Sounds
 - Alarm Lights Flash
 - The TWA flag flashes.

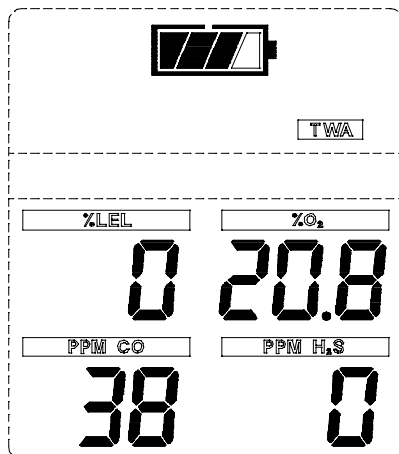

Figure 3-13. Exposure Page with TWA Alarm

To Reset the TWA:

1. Access the TWA page.
2. Press and hold the CHANGE/RESET button until the TWA flag flashes.
3. Push the ON-OFF/PAGE button to reset the TWA.

The TWA alarm is calculated over an eight-hour exposure. Calculation examples are as follows:

- 1-hour exposure of 50 PPM:

$$\frac{(1 \text{ hour} \times 50 \text{ PPM}) + (7 \text{ hours} \times 0 \text{ PPM})}{8 \text{ hours}} = 6.25 \text{ PPM}$$

- 4-hour exposure of 50 PPM
4-hour exposure of 100 PPM:

$$\frac{(4 \text{ hours} \times 50 \text{ PPM}) + (4 \text{ hours} \times 100 \text{ PPM})}{8 \text{ hours}} = 75 \text{ PPM}$$

- 12-hour exposure of 100 PPM:

$$\frac{(12 \text{ hours} \times 100 \text{ PPM})}{8 \text{ hours}} = 150 \text{ PPM}$$

NOTE: The accumulated reading is always divided by eight hours.

WARNING

If the TWA alarm condition is reached while using the instrument as a personal or area monitor, leave the contaminated area immediately; the ambient gas concentration has reached the preset TWA alarm level. Failure to follow this warning will cause over-exposure to toxic gases, which can result in serious personal injury or death.

Time Display (FIGURE 3-14)

- The TIME flag appears in the upper portion of the display to show the current time of day in a 24-hour format.

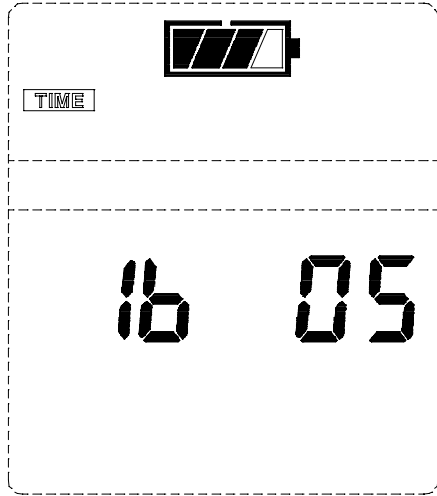

Figure 3-14. Time Display

Date Display (FIGURE 3-15)

- The MM (month), DD (day) and YY (year) flags appear in the upper portion of the display.
- The current date displays as the:
 - Month in the upper left corner
 - Day in the upper right corner
 - Year across the bottom.
- To return the display to the Measure page, press the ON-OFF/PAGE button.

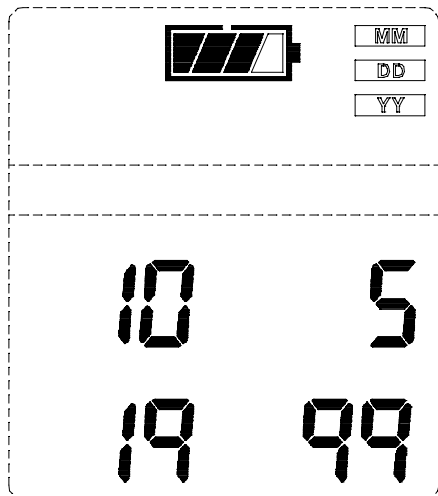

Figure 3-15. Date Display

Turning OFF the Orion Multigas Detector

Push and Hold the ON-OFF/PAGE button for five seconds.

- Gas readings end
- Hour glass displays.

NOTE: Releasing the ON-OFF/PAGE button before the five seconds elapse returns the instrument to the Measure page.

Chapter 4

Setting up the Multigas Detector

Power Systems

- The Orion Multigas Detector is supplied with an NiMH battery pack or an optional, replaceable cell, alkaline battery pack.
- See TABLE 4-1 for nominal run times by battery type.

BATTERY TYPE	HOURS (WITHOUT PUMP)	HOURS (WITH PUMP)
NiMH	20	16
Alkaline	14	10

In colder temperatures, battery output may be severely reduced. See TABLE 4-2 for capacity reductions expected for alkaline batteries at these temperatures.

TEMPERATURE	AA ALKALINE
21°C (70°F)	None
0°C (32°F)	25%
-10°C (14°F)	60%

Battery Pack Removal (FIGURE 4-1)

To remove the battery pack from the Orion Multigas Detector:

1. Remove the two screws from the bottom corner of the battery pack.
2. Gently pull out the pack by lifting the bottom out of its recess; then, slide it down.

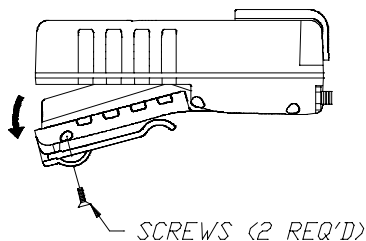

Figure 4-1. Removing the Battery

Battery Charging (NiMH Battery Pack Only)

- Charge the Orion Multigas Detector NiMH battery packs by using the Orion Fast Charger supplied with the instrument.

⚠ CAUTION

Use of any charger, other than the Orion Fast Charger supplied with the instrument, may damage or improperly charge the batteries.

- The Orion Multigas Detector must be turned OFF, or the battery pack must be removed from the instrument, prior to charging.
- The charger is capable of charging a completely depleted pack in two hours in normal, room-temperature environments.

NOTE: Allow very cold battery packs to stabilize for 1/2-hour at room temperature before attempting to charge.

To Charge the Battery Pack (A.C. Charger 10020551)

- Connect the charger cable to the charging jack located on the back of the battery pack.
- Charger status is indicated by the LED color:
 - **Amber**
The charge is pending; LED remains amber until the pack is ready to be charged.
 - **Red**
Charging is in process.

- **Green**
Charging is complete; the pack is fully charged and ready for use.
- **Red Flashing**
Failure mode; remove battery pack from charger.
- **LED OFF**
No battery pack connected.

To Charge the Battery Pack (Vehicle Charger 10026502)

1. Connect the input cable assembly to the automobile lighter and the input to the charger assembly.
2. Connect the charger cable to the charge jack located on the back of the battery pack.

Charger status is indicated by the LED color:

- **Yellow**
Battery pack temperature is outside normal operating charge range, an interconnect failure of plug and interface box has occurred.
 - Allow pack to stabilize to within 0 and 40°. If status continues, a battery pack failure or an internal circuit failure has occurred.
- **Solid Red**
Charging is in process.
- **Solid Green**
DC supply is connected to unit.
- **Flashing Red**
Charging is complete; the battery pack is fully charged and ready for use.

Once battery pack is charged, it:

- Can be disconnected from the charger
- Is ready for immediate use.

Alkaline Battery Pack

- The Orion Multigas Detector Replaceable battery pack can be used as a:
 - Full-time battery pack or
 - Backup power source.

- See TABLE 4-3 for batteries approved for use in the Orion alkaline battery pack.

Table 4-3. Batteries Approved for use in the Orion Alkaline Battery Pack			
BATTERY	UL/C-UL	EUROPE	AUSTRALIA
DURACELL MN1500	•	•	•
VARTA 4006	•	•	
Energizer E91	•	•	•

To Replace the Batteries

1. Remove battery pack from the instrument by removing the two screws located in the bottom corners of the battery pack.
2. Gently lift the pack out of its recess and pull it out.
3. Loosen the single screw that holds the plastic battery cover to the battery pack using the supplied hex key.
4. Remove the plastic cover, exposing the replaceable batteries.
5. Remove the depleted batteries.

NOTE: Follow local regulations regarding battery disposal.

6. Install the new batteries, observing the direction of the positive (+) battery terminal. The instrument will not operate if any or all cells are reversed.
7. Replace the plastic battery cover and tighten the screw.
8. Re-install the battery pack on the instrument.

Changing Instrument Settings

- Many of the Orion Multigas Detector options can be set using the two buttons on the front of the instrument.
- If the Orion Multigas Detector was ordered with the optional datalogging, the MSA FiveStar LINK software can be used to set most of the instrument selections, including some that cannot be changed from the instrument's front panel buttons.
- See TABLE 4-4 for available selections and methods for changing those selections.

Table 4-4. Available Instrument Selections and Methods for Changing Selections

OPTION	ORION FRONT-PANEL BUTTONS	FIVESTAR LINK
Viewing alarm set-points		•
Changing alarm set-points	•	•
Changing Auto-Cal values	•	
Setting Date/Time	•	•

Changing Time and Date (Datalog Equipped Instruments Only)

To Change the Time of Day:

1. Push the ON-OFF/PAGE button until the Time page appears.
2. Push and hold the CHANGE/RESET button until the TIME flag flashes.
3. Push the ON-OFF/PAGE button to change the time.
4. Push and hold the CHANGE/RESET button to advance the hour.
5. When the correct hour displays, push the ON-OFF/PAGE button once to advance to the Minutes page.
 - The minutes should be flashing.
6. Press and hold the CHANGE/RESET button to advance the minutes.
7. When the correct minute displays, push the ON-OFF/PAGE button to leave the Time Set mode.

To Change the Date:

1. Push the ON-OFF/PAGE button until the Date page appears.
2. Push and hold the CHANGE/RESET button until the MM/DD/YY flags flash.
3. Push the ON-OFF/PAGE button to change the date.
4. Push and hold the CHANGE/RESET button to advance the month.
5. When the correct month displays, push the ON-OFF/PAGE button once to advance to the Days; Days will flash.
6. Press and hold CHANGE/RESET button to advance the Days.

6. When the correct Day displays, push the ON-OFF/PAGE button once to advance to the Year.
7. Press and hold the CHANGE/RESET button to advance the Year.
8. Once the correct year displays, push the ON-OFF/PAGE button to leave the Date Set mode.

Accessing the Instrument Setup Mode (FIGURES 4-2 and 4-3)

- The Instrument Setup mode allows the user to change internal values such as:
 - Default calibration gas values for autocalibration
 - Operating beep
 - Alarm set-points for exposure, STEL and TWA
 - Calibrating tolerance.

To Access the Instrument Set-up Mode:

1. While turning the instrument ON by using the ON-OFF/PAGE button, push and hold the CHANGE/RESET button.
 - The Change flag flashes.
2. To enter the Set-up mode, push the ON-OFF/PAGE button. Pushing the Change/Reset button returns the instrument to the Measure mode.
 - The Change flag turns ON solid and stays ON as long as the instrument is in the Set-up mode.

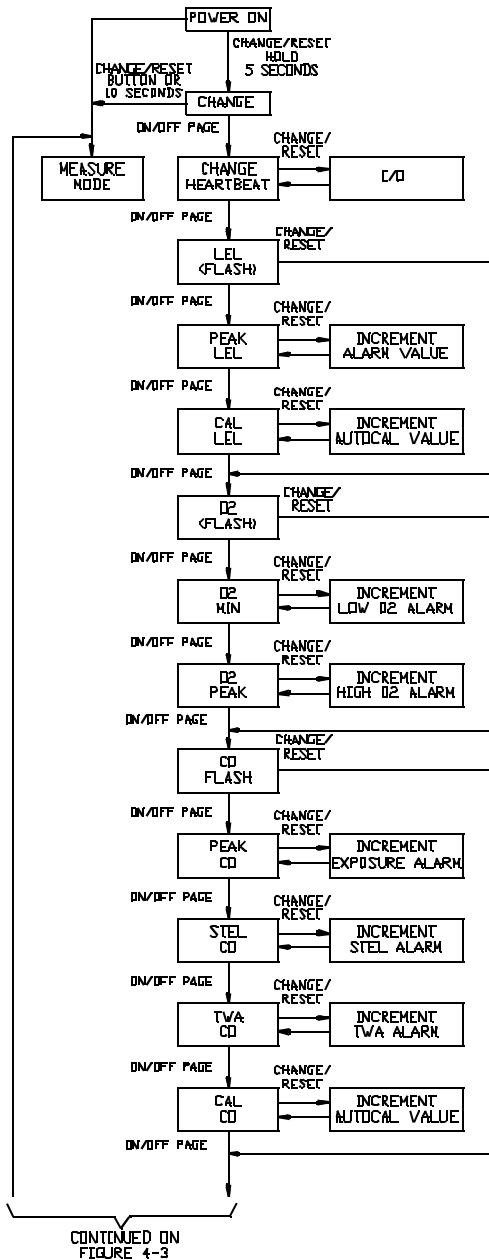

CONTINUED ON
FIGURE 4-3

Figure 4-2. Instrument Setup Mode
(part 1 of 2)

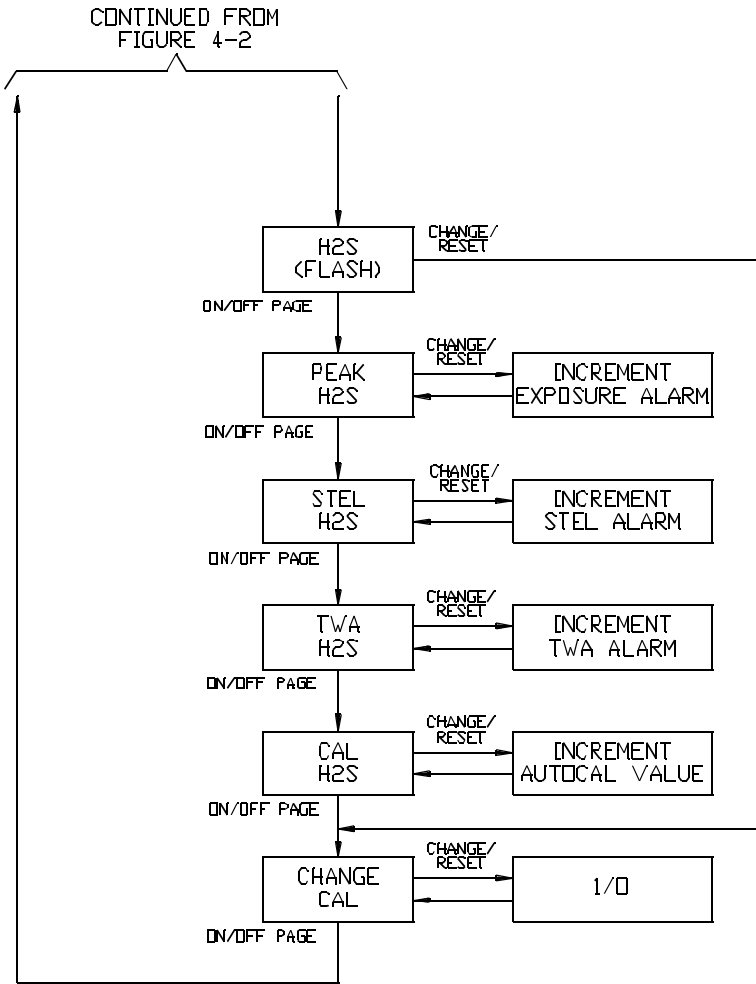

Figure 4-3. Instrument Setup Mode
(part 2 of 2)

When in the Set-up Mode, the Following Options Appear:

OPERATING BEEP

Enabling the Operating Beep causes the instrument to produce an audible beep once every 30 seconds to correspond with the Heartbeat indicator on the screen.

- The Heartbeat indicator is ON solid.
- "1" or "0" appears on the screen.
 1. Use the CHANGE/RESET button to switch between "1" and "0":
 - "1" turns ON the operating beep.
 - "0" turns OFF the operating beep.
 2. Push the ON-OFF/PAGE button to advance to the LEL set-up.

LEL SENSOR SET-UP

The LEL Sensor Set-up allows changes to be made to the LEL exposure alarm (PEAK) and to the Autocalibration value.

WARNING

Incorrectly setting the autocalibration values in the instrument could result in the instrument being incorrectly calibrated. If using calibration gas other than the gas listed in TABLE 5-1, the autocalibration values must be set to match the calibration gas. Failure to do so may result in the instrument not notifying the user of a potentially dangerous atmosphere. Failure to follow this warning can result in serious personal injury or death.

- The LEL banner flashes.
 1. Push the ON-OFF/PAGE button to make changes to the LEL settings.
 2. Push the CHANGE/RESET button to skip forward to the Oxygen Set-up.
 - The LEL Banner turns ON solid.
 - The PEAK flag turns ON.
 3. Push the CHANGE/RESET button to increment the exposure alarm (PEAK) value.
 4. Push the ON-OFF/PAGE button to accept the value.

- The LEL Banner turns ON solid.
 - The CAL flag turns ON.
5. Push the CHANGE/RESET button to increment the autocalibration value.
 6. Push the ON-OFF/PAGE button to accept the value.

OXYGEN SENSOR SET-UP

The Oxygen Sensor Set-up allows changes to be made to the:

- Oxygen sensor high alarm (oxygen enrichment)
 - Oxygen sensor Low alarm (oxygen depletion).
 - The Oxygen banner flashes.
1. Push the ON-OFF/PAGE button to change the oxygen settings.
 2. Push the CHANGE/RESET button to skip forward to the CO Set-up.
 - The Oxygen banner turns ON solid.
 - The MIN (low or deficiency alarm) flag turns ON.
 3. Push the CHANGE/RESET button to increment the MIN alarm value.
 4. Push the ON-OFF/PAGE button to accept the value.
 - The Oxygen banner turns ON solid
 - The PEAK (high or enrichment alarm) flag turns ON.
 5. Push the CHANGE/RESET button to increment the PEAK alarm value.
 6. Push the ON-OFF/PAGE button to accept the value.

CARBON MONOXIDE (CO) SENSOR SET-UP

The CO Sensor Set-up allows changes to be made to the:

- CO sensor exposure alarm (PEAK)
 - STEL alarm
 - TWA alarm and autocalibration value.
 - The CO banner flashes.
1. Push the ON-OFF/PAGE button to make changes to the CO settings.

2. Push the CHANGE/RESET button to skip forward to the H₂S Set-up.
 - The CO banner turns ON solid.
 - The PEAK (exposure alarm) flag turns ON.
3. Push the CHANGE/RESET button to increment the PEAK alarm.
4. Push the ON-OFF/PAGE button to accept the setting.
 - The CO banner turns ON solid
 - The STEL (Short Term Exposure Limit) flag turns ON.
5. Push the CHANGE/RESET button to increment the STEL alarm.
6. Push the ON-OFF/PAGE button to accept the setting.
 - The CO banner turns ON solid.
 - The TWA (Time Weighted Average) flag turns ON.
7. Push the CHANGE/RESET button to increment the TWA alarm.
8. Push the ON-OFF/PAGE button to accept the setting.
 - The CO Banner turns ON solid.
 - The CAL flag turns ON.
9. Push the CHANGE/RESET button to increment the autocalibration value.
10. Push the ON-OFF/PAGE button to accept the value.

HYDROGEN SULFIDE (H₂S) SENSOR SET-UP

The H₂S Sensor Set-up allows changes to be made to the:

- H₂S sensor exposure alarm (PEAK)
 - STEL alarm
 - TWA alarm
 - autocalibration value.
 - The H₂S banner flashes.
1. Push the ON-OFF/PAGE button to make changes to the H₂S settings.
 2. Push the CHANGE/RESET button to skip forward to the Expanded Tolerance Calibration Window Page.
 - The H₂S banner turns ON solid.

- The PEAK (exposure alarm) flag turns ON.
- 3. Push the CHANGE/RESET button to increment the PEAK alarm.
- 4. Push the ON-OFF/PAGE button to accept the setting.
 - The H₂S banner turns ON solid.
 - The STEL (Short Term Exposure Limit) flag turns ON.
- 5. Push the CHANGE/RESET button to increment the STEL alarm.
- 6. Push the ON-OFF/Page button to accept the setting.
 - The H₂S banner turns ON solid.
 - The TWA (Time Weighted Average) flag turns ON.
- 7. Push the CHANGE/RESET button to increment the TWA alarm.
- 8. Push the ON-OFF/PAGE button to accept the value.
 - The H₂S Banner turns ON solid.
 - The CAL flag turns ON.
- 9. Push the CHANGE/RESET button to increment the autocalibration value.
- 10. Push the ON-OFF/PAGE button to accept the value.

EXPANDED TOLERANCE CALIBRATION WINDOW PAGE

This page is used to remove the limitations normally placed on autocalibration limits. Autocalibration will only calibrate a particular sensor if it is within an allowable window around the expected autocalibration value. If the gas applied during autocalibration is not within that window:

- The sensor will not be calibrated.
- The instrument will alarm to indicate that the sensor remains uncalibrated.

Occasionally, it is necessary to remove the limits and allow the instrument to calibrate over a much wider window. For example: the installation of a new sensor may require that the limits be expanded, since the output of the new sensor may be much higher than the old sensor it is replacing. This most often occurs with oxygen and combustible (LEL) sensors.

- The CAL flag turns ON solid.

- "1" or "0" appears on the screen.
 1. Use the CHANGE/RESET button to switch between "1" and "0".
 - "1" selects the normal, limited calibration window.
 - "0" selects the expanded tolerance mode.
 2. Push the ON-OFF/Page button to accept the selection.

NOTE: The expanded tolerance window ("0") will be active for one calibration attempt.

 - The Orion Multigas Detector exits the Set-Up mode and automatically enters the Measure mode.
- NOTE:** The expanded tolerance window can also be accessed from the Calibration Failure screen if a calibration failure occurs using the standard calibration window. See Chapter 5, Calibration, for more information.

Chapter 5

Calibration

Calibrating the Orion Multigas Detector

Each Orion Multigas Detector is equipped with an autocalibration feature to make unit calibration as easy as possible.

The Autocalibration sequence resets instrument zeroes and adjusts sensor calibration for known concentrations of calibration gases.

Table 5-1. Autocalibration and Required Calibration Cylinders

SENSORS	EXPECTED GAS CONCENTRATION	FOUR GAS CYLINDER (P/N 804770, 711058)	THREE GAS CYLINDER (P/N 10010162)
Combustible	58% LEL	•	•
Oxygen	15%	•	•
Carbon Monoxide	300 ppm	•	•
Hydrogen Sulfide	10 ppm	•	

To Calibrate the Orion Multigas Detector (FIGURE 5-1):

1. Turn ON the instrument and verify that battery is sufficiently charged.
2. Push and hold the CHANGE/RESET button until the ZERO flag flashes in the upper portion of the display (FIGURE 5-2).
 - Indicates instrument is in the Calibration mode.
3. Push the ON-OFF/PAGE button to zero the instrument.
 - You must be in fresh air to perform the zero.
 - The ZERO flag stops flashing and remains ON.

NOTE: To skip the zero procedure and move directly to the calibration span procedure, push the CHANGE/RESET button. If no button is pushed for 10 seconds, the instrument returns to the Measure mode.

- Once the zeros are set, CAL flag flashes (FIGURE 5-3).

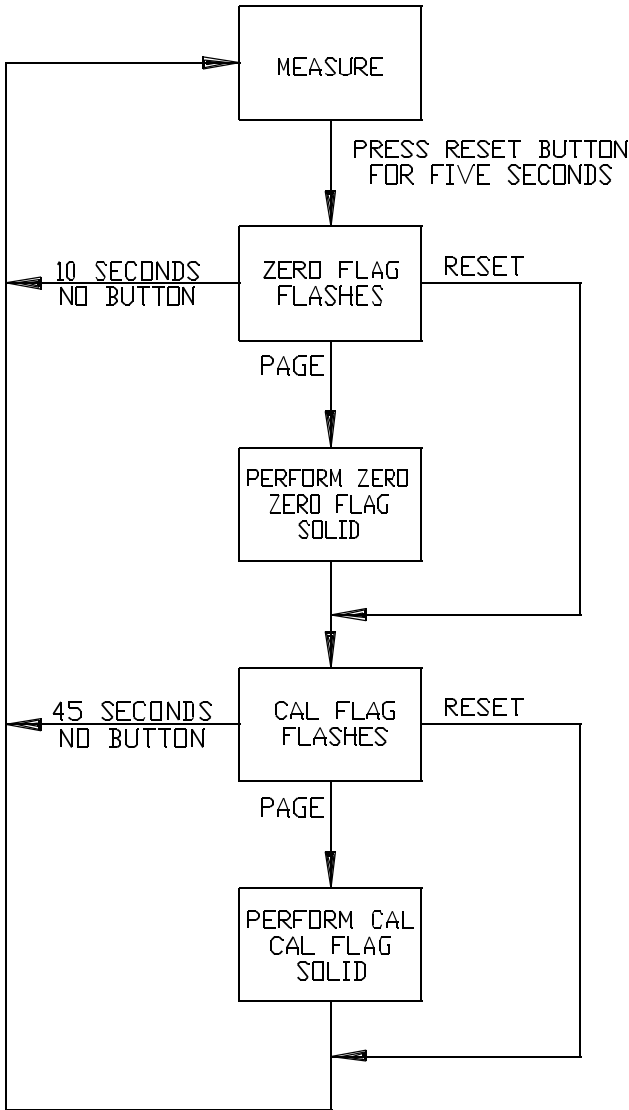

Figure 5-1. Calibration Flow Chart

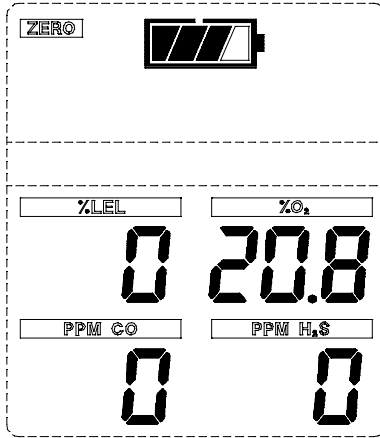

Figure 5-2. Zero Flag

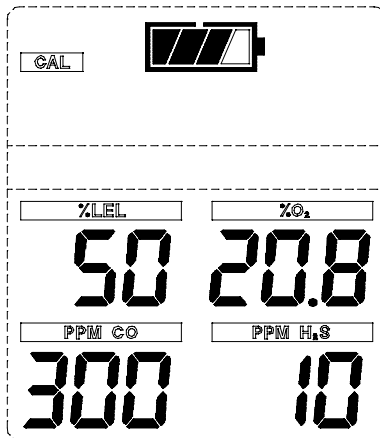
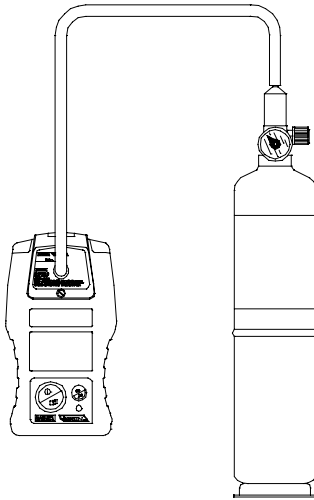

Figure 5-3. CAL Flag

4. Connect the appropriate calibration gas to the instrument.
 5. a. **For Diffusion Instruments** (FIGURE 5-4):
Attach the calibration cap to the instrument.
 - 1) Connect one end of the tubing to the calibration cap.
 - 2) Connect other end of tubing to the cylinder regulator (supplied in the calibration kit).
 - b. **For Pumped Instruments** (FIGURE 5-5):
 - 1) Connect one end of tubing to instrument inlet fitting.
 - 2) Connect other end of tubing to the cylinder regulator (supplied in the calibration kit).
 6. Open the valve on the regulator.
 7. Push the ON-OFF/PAGE button to calibrate (span) the instrument.
 - CAL flag stops flashing and remains ON.
 - Instrument cycles through the gases one-at-a-time for approximately 90 seconds.
 - If autocalibration sequence passes, the instrument returns to the Measure mode.
- NOTE:** To skip calibration and return to the Measure mode, push the CHANGE/RESET button.
If no button is pushed for 10 seconds, the instrument returns to the Measure mode.
8. Remove the calibration cap or tubing from the pump inlet.
 9. Close the valve on the regulator.
- NOTE:** The autocalibration procedure adjusts the span value for any sensor that passes the test; sensors that fail autocalibration are left unchanged.
- NOTE:** Since residual gas may be present, the instrument may briefly go into an exposure alarm after the calibration sequence is completed.

Autocalibration Failure

If the Orion Multigas Detector cannot calibrate one or more sensor(s), the instrument goes into the Autocalibration Failure Page and remains in alarm until the CHANGE/RESET button is pushed. Sensors that could not be calibrated are indicated by dashed lines on the concentration display.



*Figure 5-4. Typical Calibration Setup -
for Diffusion with Cal Cap*

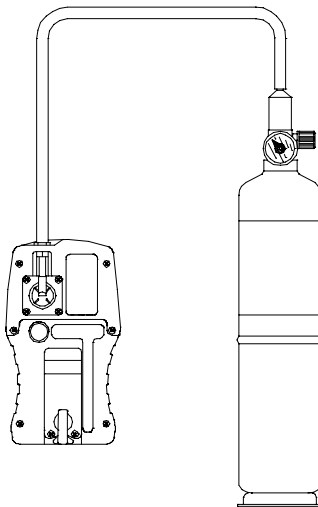

*Figure 5-5. Typical Calibration Setup -
for Pumped Versions*

Accessing the Expanded Tolerance Calibration

Check that:

- all appropriate sensors are installed and in their correct location
- the calibration setup is correct and verify that:
 - all connections are secure
 - the proper gas regulator and cylinder are being used.

If the setup is correct, it may be necessary to calibrate the instrument using the Expanded Tolerance Calibration window.

From the Autocalibration Failure page:

1. Do NOT push the CHANGE/RESET button.
 - The CAL flag continues to display.
2. Do NOT remove the calibration gas; it must continue to flow from the initial calibration attempt.
3. Press and hold the ON-OFF/PAGE button for approximately three seconds.
 - The hourglass displays until the CHANGE flag appears on the display.
4. Release the ON-OFF/PAGE button.
 - The instrument takes approximately 10 seconds to calibrate using the Expanded Tolerance Calibration window.
 - If the calibration is successful, the instrument returns to the Measure page.
 - If the calibration is not successful, the Autocalibration Failure page displays again. The above procedure can be repeated indefinitely but is not likely to yield a successful calibration. Before proceeding, check the following:
 - Cylinder type -
Ensure that the values on the cylinder match the Autocalibration values programmed into the Orion.
 - Cylinder pressure -
Ensure that the cylinder is not empty.
 - Pressure regulator -
Ensure that the pressure regulator has a flow of 0.25 LPM. (See TABLE 8-1 for the correct MSA part-numbered regulators.)

- **Sensors -**
Ensure that sensors are all present and in the correct slots.
Ensure that the sensor has not exceeded its useful life; replace the sensor if necessary.
- **Tubing -** Ensure that tubing is not blocked or kinked.

Chapter 6

Warranty, Maintenance and Troubleshooting

MSA Portable Instrument Warranty

1. Warranty-

ITEM	WARRANTY PERIOD
Chassis and electronics	Lifetime (MSA will support product for five years after production ends)
All sensors, unless otherwise specified	Two years
Pump and drive unit	Two years
Rechargeable batteries	Two years

This warranty does not cover filters, fuses, etc. Certain other accessories not specifically listed here may have different warranty periods. This warranty is valid only if the product is maintained and used in accordance with Seller's instructions and/or recommendations. The Seller shall be released from all obligations under this warranty in the event repairs or modifications are made by persons other than its own or authorized service personnel or if the warranty claim results from physical abuse or misuse of the product. No agent, employee or representative of the Seller has any authority to bind the Seller to any affirmation, representation or warranty concerning this product. Seller makes no warranty concerning components or accessories not manufactured by the Seller, but will pass on to the Purchaser all warranties of manufacturers of such components. **THIS WARRANTY IS IN LIEU OF ALL OTHER WARRANTIES, EXPRESSED, IMPLIED OR STATUTORY, AND IS STRICTLY LIMITED TO THE TERMS HEREOF. SELLER SPECIFICALLY DISCLAIMS ANY WARRANTY OF MERCHANTABILITY OR OF FITNESS FOR A PARTICULAR PURPOSE.**

2. **Exclusive Remedy-** It is expressly agreed that Purchaser's sole and exclusive remedy for breach of the above warranty, for any tortious conduct of Seller, or for any other cause of action, shall be the repair and/or replacement at Seller's option, of any equipment or parts thereof, which after examination by Seller is proven to be defective. Replacement equipment and/or parts will be provided at no cost to Purchaser, F.O.B. Seller's Plant. Failure of Seller to successfully repair any nonconforming product shall not cause the remedy established hereby to fail of its essential purpose.
3. **Exclusion of Consequential Damages-** Purchaser specifically understands and agrees that under no circumstances will seller be liable to purchaser for economic, special, incidental or consequential damages or losses of any kind whatsoever, including but not limited to, loss of anticipated profits and any other loss caused by reason of nonoperation of the goods. This exclusion is applicable to claims for breach of warranty, tortious conduct or any other cause of action against seller.

Cleaning and Periodic Checks

As with all electronic equipment, the Orion Multigas Detector will operate only if it is properly maintained.

WARNING

Repair or alteration of the Orion Multigas Detector, beyond the procedures described in this manual or by anyone other than a person authorized by MSA, could cause the instrument to fail to perform properly. Use only genuine MSA replacement parts when performing any maintenance procedures described in this manual. Substitution of components can seriously impair instrument performance, alter intrinsic safety characteristics or void agency approvals.

FAILURE TO FOLLOW THIS WARNING CAN RESULT IN SERIOUS PERSONAL INJURY OR DEATH.

Cleaning and Routine Care

Periodically clean the Orion Multigas Detector case with a soft damp cloth. On diffusion instruments: clean sensor holes on the instrument front if they are blocked with dirt.

1. Remove the sensor cover plate, sensor membrane, and sensor cover gasket (see Chapter 8, FIGURE 8-1).
2. Clean the sensor plate holes with a paper clip, wire, or similar device. The holes may also be cleaned with oil-free compressed air.
3. Replace sensor membrane with a new one.

WARNING

Do not attempt to clean the sensor cover plate while it is in place; sensor damage may occur. The tops of sensors are very fragile; do not touch or apply pressure to the tops of any sensors. If a sensor is damaged, it can cause the unit to give false readings.

The sensor cover plate contains holes for four sensors. In instruments with less than four sensors, some of the holes are permanently blocked with special sealing membranes. Do not puncture these membranes; erroneous gas readings can result.

Checking The Pump Inlet Filter

Orion Multigas Detectors ordered with the optional internal pump contain a filtering system to protect the pump from particles and water in the sample air. If the filter becomes clogged, the sample flow may be blocked, or an extra load may be placed on the pump; therefore, check the filter regularly.

The frequency of checks should depend on amount of pump usage and concentration of particles allowed to enter the pump. In dirty applications, replace the dust filter every 200 hours.

Replacing the Filters

CAUTION

When replacing external dust and water filters, prevent any dust or dirt around the filter housing from entering the pump housing. Dust or dirt in the pump unit may impede pump operation.

Dust Filter (see FIGURE 8-2 and TABLE 8-2)

1. Remove the four screws (24) from the clear filter housing (23) on the back of the instrument.
2. Remove the fibrous dust filter (21) from the recess on the filter housing.
3. Carefully install the new dust filter in the filter housing recess.
4. Re-install the filter housing.

Water Filter

1. Remove the four screws (24) from the clear filter housing (23) on the back of the instrument.
2. Carefully lift out the O-ring (26) and white plastic filter (20) resting in the filter housing.
3. Carefully install the new water filter in the filter housing recess.

NOTE: When replacing the filter, carefully handle the new filter by the edges only, as it is easily torn. Install the filters in the correct order.

4. Replace the O-ring, being sure to press gently down on top of the water filter.
5. Replace the cover and screws.

Internal "Firewall" Filter (see FIGURES 8-1 and 8-2 and TABLE 8-2)

The pumped version of the Orion Multigas Detector contains an internal "firewall" filter. This filter forms a final barrier against any dust that enters the pump assembly when external filters are replaced. The "firewall" filter is provided as a final safety precaution and should rarely, if ever, require replacement.

1. Turn OFF the power.
2. Remove the battery pack from the instrument by removing the bottom two screws on the back of the case.

3. Remove the pump cover or calibration cap, if installed.
4. Remove the sensor cover and sensors.
5. Remove the four remaining case mounting screws from the back of the case.

CAUTION

When removing the back of the case, be careful not to pull the pump wires from the connector. Use minimum force necessary to disengage this connector to prevent breakage.

6. Remove the pump connector. Observe polarity; the red wire should be toward the center of the circuit board.
7. Disconnect the pump outlet tube; place a small, flat screwdriver at the base of the tube and gently pry the tube away from the barb.
8. Remove the firewall filter and discard.
9. Install the new firewall filter (27) with flow arrow pointing toward the pump and drive inlet. Ensure that the tube from the pump outlet is routed to the inside of the firewall filter.
10. Position the rear case 90 degrees up from the front case; route the pump outlet tube between the pump and the in-line filter and connect it to the barb protruding through the circuit board.
11. Connect the pump cable.
NOTE: Be careful to use proper polarity; the red wire should be toward the center of the circuit board.
12. Replace and secure the back of the case with the four mounting screws.
13. Replace the battery pack and two mounting screws securing the battery pack.
14. Completely recalibrate the Orion Multigas Detector.

WARNING

Verification of calibration response is required; otherwise, the instrument will not perform as required, and persons who rely on this product for their safety could sustain serious personal injury or death.

Probe Filter

- The MSA sampling probe contains a filter to:
 - block dust and dirt
 - block the passage of water.
- If the probe tip is accidentally submerged in water, the filter prevents the water from reaching the internal pump. The filter is not designed to stop other liquids, such as gasoline or alcohols.

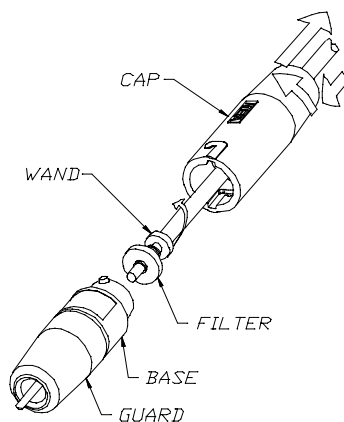

Figure 6-1. Replacing the Probe Filter

To Replace the Probe Filter (FIGURE 6-1):

1. Grasp the probe handle by the base and guard.
2. Push the cap section toward the other two and turn clockwise.
 - The spring pushes the sections apart.
3. Grasp and spin the wand clockwise while pulling to disengage.
4. Remove the water trap filter (P/N 801582) and replace.

Storage

- When not in use, store your Orion Multigas Detector in a safe, dry place between -5° and 40°C (23° and 104°F).
- The Orion Multigas Detector with the NiMH rechargeable battery pack can be stored on charge indefinitely.

⚠ WARNING

After storage, always recheck instrument calibration before use. During storage, sensors may drift or become inoperative and may not provide warnings of dangers to the health and lives of users.

Shipment

1. Remove battery pack before shipment. When returning the Orion Multigas Detector for repairs, disconnect the normally used battery pack from unit, and include it in the container.
2. Pack the Orion Multigas Detector in its original shipping container with suitable padding. If the original container is unavailable, an equivalent container may be substituted. Seal instrument in a plastic bag to protect it from moisture. Use sufficient padding to protect it from the rigors of handling. Damage due to improper packaging or damage in shipment is not covered by the instrument's warranty.

Troubleshooting

The Orion Multigas Detector will operate reliably for years when cared for and maintained properly. If the instrument becomes inoperative, follow the Troubleshooting Guidelines in TABLE 6-1; these represent the most likely causes of a problem. You may return inoperative instruments to MSA for repair.

- **MSA Instrument Division**
Repair and Service Department
1000 Cranberry Woods Drive
Cranberry Township, PA 16066-5207
1-800-MSA-INST

To contact MSA International, please call:

- **1-412-967-3000** or **1-800-MSA-7777**

The instrument displays an error code if it detects a problem during startup or operation. See TABLE 6-1 for a brief description of the error and proper corrective action. When an inoperative component is located by using the guidelines, it may be replaced by using one of the following "Repair Procedures:"

Table 6-1. Troubleshooting Guidelines

PROBLEM	REPLACE			
	BATTERY PACK*	DISPLAY MODULE	SENSOR	MAIN ELECTRONICS MODULE
Does not turn ON	•			•
Does not complete Self-Tests				•
Display segments missing or stuck		•		
"ERROR" message after battery installation				•
"ERROR" message during use				•
Battery pack does not hold charge	•			
Combustible sensor does not calibrate			•	
Oxygen sensor does not calibrate			•	
Toxic sensor does not calibrate			•	
Clock not holding time.				•
* Recharge or replace the cells before replacing battery pack.				
In all of the above cases and for any other problems, you may return the Orion Multigas Detector to MSA for repairs.				

ERROR CODE	DESCRIPTION	CORRECTIVE ACTION
1	Main Board Error	Check/replace main board
2	Display Error	Check/replace main board; check display cable
3	EEPROM Error	Reinitialize the instrument (follow procedure for manual sensor configuration and answer yes to query to reinitialize the EEPROM)
4	Combustible Sensor Error	Check/replace combustible sensor
5	Oxygen Sensor Error	Check/replace oxygen sensor
6	Cannot Write EEPROM	Check/replace main board
7	Battery Type Failure	Replace battery pack
8	Blown Alarm Fuse	Replace battery pack

Repair Procedures

Battery Pack Replacement

Remove the Battery Pack

1. Remove the two battery mounting screws on the back of the instrument.
2. Pull out the battery pack by gripping it at the edge of the battery pack case and pulling it away from the unit.

Replace the Battery Pack

3. Insert the front of the battery pack under the lip on the case and snap the bottom of the battery pack into the case.
4. Install and tighten the battery mounting screws.

Sensor Replacement

1. Verify that the instrument is turned OFF; remove battery pack.
2. If your unit is a pumped version, remove the pump cover by removing the screw with a 1/16" hex key.
3. Remove the sensor cover screws and cover.
4. Gently lift out the sensor to be replaced; properly dispose of sensor.

NOTE: Sensor positions cannot be changed. Each sensor location is identified by a label in the bottom of each sensor well. When replacing a sensor, ensure that the gas type printed on the sensor label matches the sensor identification label in the instrument.

5. If replacement sensor is equipped with a shorting plate, clip or wire attached to its pins, remove plate, clip or wire before inserting the replacement sensor.
6. Carefully align the new sensor contact pins with the sockets on the printed circuit board.
7. Press the new sensor into place.
8. Replace the sensor gasket and sensor cover.

9. Re-install the screws to hold down the sensor cover.

WARNING

Verification of calibration response is required; otherwise, the instrument will not perform as required, and persons relying on this product for their safety could sustain serious personal injury or death.

Main Electronics Board Replacement

CAUTION

Before handling the circuit boards, ensure you are properly grounded; otherwise, static charges from your body could damage the electronics. Such damage is not covered by the warranty. Grounding straps and kits are available from electronics suppliers.

1. Turn OFF the power.
2. Remove the battery pack.
3. Remove the pump cover or calibration cap, if installed.
4. Remove the sensor cover and sensors.
5. Remove the four remaining case mounting screws from the back of the case.

CAUTION

When removing the back of the case, be careful not to pull the pump wires from the connector. Use minimum force necessary to disengage this connector to prevent breakage.

6. Remove the pump connector.
7. Disconnect the pump outlet tube; place a small, flat screwdriver at the base of the tube and gently pry the tube away from the barb.
8. Tilt the circuit board up at a 90 degree angle to gain access to the connectors on the under-side of the circuit board.
9. Remove the display ribbon cable by sliding out the locking tabs on the side of the connector.
10. Remove the membrane switch ribbon cable by sliding out the locking tabs on the side of the connector.

11. Disconnect the back light fiber optics bundle by spreading the two clips which hold the back of the LED onto the circuit board.
12. Connect the new circuit board to the membrane switch ribbon cable; latch down the two tabs located on either side of the ribbon socket.
13. Connect the display ribbon cable; latch down the two tabs located on either side of the ribbon socket.
14. Connect the back light fiber optics bundle; snap the connector over the LED on the circuit board.
15. Position the circuit board into the case, carefully lining up the connector for the IR Link circuit board, if so equipped.
16. If the instrument is equipped with a pump, position the rear case 90 degrees up from the front case; route the pump outlet tube between the pump and the in-line filter and connect it to the barb protruding through the circuit board.
17. If the instrument is equipped with a pump, connect the pump cable.

NOTE: Be careful to use proper polarity; the red wire should be toward the center of the circuit board.

18. Replace and secure the back of the case with the four mounting screws.
19. Replace the battery pack and two mounting screws securing the battery pack.
20. Completely recalibrate the Orion Multigas Detector.

WARNING

Verification of calibration response is required; otherwise, the instrument will not perform as required, and persons who rely on this product for their safety could sustain serious personal injury or death.

Display Assembly Replacement

CAUTION

Before handling the circuit boards, ensure you are properly grounded; otherwise, static charges from your body could damage the electronics. Such damage is not covered by the warranty. Grounding straps and kits are available from electronics suppliers.

1. Turn OFF the power.
2. Remove the battery pack.
3. remove the pump cover or calibration cap, if installed.
4. Remove the sensor cover and sensors.
5. Remove the four remaining case mounting screws from the back of the case.

CAUTION

When removing the back of the case, be careful not to pull the pump wires from the connector. Use minimum force necessary to disengage this connector to prevent breakage.

6. Remove the pump connector.
7. Disconnect the pump outlet tube. Place a small, flat screwdriver at the base of the tube and gently pry the tube away from the barb.
8. Tilt the circuit board up at a 90-degree angle to gain access to the connectors on the under side.
9. Remove the display ribbon cable by sliding out the locking tabs on the side of the connector.
10. Remove the membrane switch ribbon cable by sliding out the locking tabs on the side of the connector.
11. Disconnect the back light fiber optics bundle by spreading the two clips which hold the back of the LED onto the circuit board.
12. Use a sharp X-acto knife to cut the green display mount from the four mounting posts; be careful not to damage the mounting posts.

13. Carefully holding the membrane switch ribbon cable out of the way so as not to damage it, remove the old display assembly.
14. Align the new display assembly over the four mounting posts; gently push the green display mount over the mounting posts until it is fully engaged on the mounting posts.
15. Connect the new circuit board to the membrane switch ribbon cable; latch down the two tabs located on either side of the ribbon socket.
16. Connect the display ribbon cable; latch down the two tabs located on either side of the ribbon socket.
17. Connect the back light fiber optics bundle; snap the connector over the LED on the circuit board.
18. Position the circuit board in the case; be careful to line up the connector for the IR Link circuit board, if so equipped.
19. If equipped with a pump, position the rear case at a 90-degree angle from the front case and connect the pump outlet tube to the barb protruding through the circuit board; route the outlet tube between the pump and the in-line filter.
20. If equipped with a pump, connect the pump cable, positioning the red wire toward the center of the circuit board.
21. Replace the back of the case and install four mounting screws securing the back of the case.
22. Replace the battery pack and the two mounting screws which secure the battery pack.
23. Completely recalibrate the Orion Multigas Detector.

 WARNING

Verification of calibration response is required; otherwise, the instrument will not perform as required, and persons who rely on this product for their safety could sustain serious personal injury or death.

Horn Assembly Replacement

The Horn Assembly must be replaced at an authorized factory service center.

Pump Replacement

⚠ CAUTION

Before handling the circuit boards, ensure you are properly grounded; otherwise, static charges from your body could damage the electronics. Such damage is not covered by the warranty. Grounding straps and kits are available from electronics suppliers.

1. Turn the power OFF.
2. Remove the battery pack.
3. Remove the pump cover or calibration cap, if installed.
4. Remove the sensor cover and sensors.
5. Remove the four remaining case mounting screws from the back of the case.

⚠ CAUTION

When removing the back of the case, be careful not to pull the pump wires from the connector. Use minimum force necessary to disengage this connector to prevent breakage.

6. Remove the pump connector.
7. Disconnect the pump outlet tube. Place a small, flat screwdriver at the base of the tube and gently pry the tube away from the barb.
8. Remove the mounting screw and disc which retains the pump.
9. Remove the pump; gently pry the pump inlet tube from the elbow fitting, be careful not to damage the elbow fitting.
10. Install the new pump; re-install the mounting screw and disc, and attach the pump inlet tube to the elbow fitting.
11. Position the rear case at a 90-degree angle from the front case and connect the pump outlet tube to the barb protruding through the circuit board; route the outlet tube between the pump and the in-line filter.
12. Connect the pump cable.

NOTE: Be careful to use proper polarity; the red wire should be toward the center of the circuit board.

13. Replace the back of the case and the four mounting screws which secure the back of the case.
14. Replace the battery pack and the two mounting screws securing the battery pack.
15. Completely recalibrate the Orion Multigas Detector.

 WARNING

Verification of calibration response is required; otherwise, the instrument will not perform as required, and persons who rely on this product for their safety could sustain serious personal injury or death.

Chapter 7

Performance Specifications

Table 7-1. Certifications		
HAZARDOUS LOCATIONS	US	UL 913 for Class 1, Div. 1, Groups A, B, C and D
	CANADA	CSA C22.2 No. 157 for Class 1, Div. 1, Groups A, B, C and D
	EUROPE	EN 50014/EN 50020/EN 500018 EExiadIIc -20°C to +50°C
	AUSTRALIA	AS/NZS 60079-11 ExiasIIc -20°C to +50°C
AS/NZS 61779-1		
EMC/RFI	US	47 CFR, part 15
	EUROPE	EN 50270 (EN 50081-1/50082-2)
	AUSTRALIA	C-tick emissions (CSPR11)
PERFORMANCE	CANADA	CSA C22.2 No. 152
	EUROPE	IEC 529 IP54 min.
	AUSTRALIA	AS/NZS 61779 -1/61779-4
SAFETY	EUROPE	CE: LVD (low voltage directive), EN61010-1 for chargers and accessories requiring greater than 50 VAC or 75 VDC
ATEX	EUROPE	CE EX II 2G EExiadIIc (T3 Varta Alkaline AA) -20°C to +50°C
		Directive 94/9/CE
		CE: EMC/RFI

Table 7-2. Instrument Specifications

TEMPERATURE RANGE	Normal	0 to 40° C		
	Extended**	-20 to 50° C		
WARM-UP TIME		20 seconds; 25 seconds with pump		
<p>*NOTE 1: Response times reported for diffusion usage: When using a pump module and sample line, add time for the gas sample to be drawn through the sample line. Typical transport times are:</p>				
	5 feet	3 seconds		
	10 feet	7 seconds		
	50 feet	15 seconds		
These should be added to the sensor response times reported in this chapter.				
<p>**NOTE 2: Extended temperature range indicates that gas readings may vary slightly if calibrated at room temperature. For optimal performance, it is recommended that the instrument be calibrated at temperature of use.</p>				
Measurement Methods				
COMBUSTIBLE GAS	Catalytic Sensor			
OXYGEN	Electrochemical Sensor			
TOXIC GASES	Electrochemical Sensors			
Factory-Set Alarm Setpoints				
	HIGH ALARM	LOW ALARM	STEL	TWA
CO	35 PPM	--	400	35
H₂S	10 PPM	--	15	10
LEL	10% LEL	--	--	--
O₂	22.0%	19.5%	--	--

Table 7-3. COMBUSTIBLE GAS - Typical Performance Specifications

RANGE	0 to 100% LEL
RESOLUTION	1% LEL
REPRODUCIBILITY	3% LEL to 50% LEL reading
	5% LEL to full scale or
RESPONSE TIME	90% of final reading in 30 seconds (normal temperature range)*

*See TABLE 7-2, NOTE 1.

Table 7-4. COMBUSTIBLE GAS - Cross Reference Factors for Orion General-Purpose Calibration Using Calibration Cylinder (P/N 478191), (P/N 478192), (P/N 804769), or (P/N 804770) Set to 58% LEL

COMBUSTIBLE GAS	MULTIPLY %LEL READING BY	COMBUSTIBLE GAS	MULTIPLY %LEL READING BY
Acetone	1.1	Methyl Isobutyl ketone	1.1
Acetylene	0.7	Methylcyclohexane	1.1
Acrylonitrile ¹	0.8	Methyl Ethyl Ketone	1.1
Benzene	1.1	Methyl Tertiary Butyl Ether	1.0
Butane	1.0	Mineral Spirits	1.1
1,3 Butadiene	0.9	iso-Octane	1.1
n-Butanol	1.8	n-Pentane	1.0
Carbon Disulfide ¹	2.2	Propane	0.8
Cyclohexane	1.1	Propylene	0.8
2,2 Dimethylbutane	1.2	Styrene ²	1.9
2,3 Dimethylpentane	1.2	Tetrahydrofuran	0.9
Ethane	0.7	Toluene	1.1
Ethyl Acetate	1.2	Vinyl Acetate	0.9
Ethyl Alcohol	0.8	VM&P Naptha	1.6
Ethylene	0.7	O-Xylene	1.2
Formaldehyde ²	0.5	RESPONSE NOTES: 1. The compounds may reduce the sensitivity of the combustible gas sensor by poisoning or inhibiting the catalytic action. 2. These compounds may reduce the sensitivity of the combustible gas sensor by polymerizing on the catalytic surface. 3. For an instrument calibrated on Pentane, multiply the displayed %LEL value by the conversion factor above to get the true %LEL. 4. These conversion factors should be used only if the combustible gas is known. 5. These conversion factors are typical for a Orion Multigas Detector. Individual units may vary by $\pm 25\%$ from these values.	
Gasoline (unleaded)	1.3		
Heptane	1.1		
Hydrogen	0.6		
n-Hexane	1.3		
Isobutane	0.9		
Isobutyl Acetate	1.5		
Isopropyl Alcohol	1.1		
Methane	0.5		
Methanol	0.6		

Table 7-5. OXYGEN - Typical Performance Specifications

RANGE	0 to 25% O ₂	
RESOLUTION	0.1% O ₂	
REPRODUCIBILITY	0.3% O ₂ , for 2 to 25% O ₂	
RESPONSE TIME	90% of final reading	30 seconds (normal temperature range)*
		3 minutes (extended temperature range)
*See TABLE 7-2, NOTE 1.		

Environment and Oxygen Sensor Readings

A number of environmental factors may affect the oxygen sensor readings, including changes in pressure, humidity and temperature. Pressure and humidity changes affect the amount of oxygen actually present in the atmosphere.

Pressure Changes

The Orion oxygen sensor is designed to compensate for ambient pressure changes in the area of instrument operation. If pressure changes rapidly (e.g., stepping through airlock) the oxygen sensor reading may temporarily shift, and possibly cause the detector to go into alarm. While the percentage of oxygen may remain at or near 20.8%, the total amount of oxygen present in the atmosphere available for respiration may become a hazard if the overall pressure is reduced to a significant degree.

Humidity Changes

If humidity changes to any significant degree (e.g., going from a dry, air conditioned environment to outdoor, moisture laden air), oxygen levels can change up to 0.5%. This is due to water vapor in the air displacing oxygen, thus reducing oxygen readings as humidity increases. The oxygen sensor has a special filter to reduce the affects of humidity changes on oxygen readings. This effect will not be noticed immediately, but slowly impacts oxygen readings over several hours.

Temperature Changes

The oxygen sensor has built-in temperature compensation. However, if temperature shifts dramatically, the oxygen sensor reading may shift. Zero the instrument to within 30°C of the temperature-of-use for the least effect.

Table 7-6. CARBON MONOXIDE (appropriate models only) - Typical Performance Specifications

RANGE	999 ppm CO
RESOLUTION	1 ppm CO
REPRODUCIBILITY	± 2 ppm CO or 10% of reading, whichever is greater
RESPONSE TIME	90% of final reading in 30 seconds (normal temperature range)

*See TABLE 7-2, NOTE 1.

Table 7-7. CARBON MONOXIDE - Cross Reference Factors for Orion Calibration Using Calibration Cylinder (P/N 478191) or (P/N 804770)

NOTE: Data is presented as the indicated output in ppm, which would result from the application of 100 ppm of the test gas.

TEST GAS (100 PPM)	EQUIVALENT PPM
Carbon Monoxide (CO)	100 ± 9
Hydrogen Sulfide (H ₂ S)	1 ± 6
Sulfur Dioxide (SO ₂)	0 ± 1
Nitrogen Dioxide (NO ₂)	2 ± 6
Nitric Oxide (NO)	70 ± 10
Chlorine (Cl ₂)	1 ± 8
Ammonia (NH ₃)	2 ± 4
Hydrogen Chloride (HCl)	3 ± 2
Ethylene (C ₂ H ₄)	80 ± 9
Hydrogen Cyanide (HCN)	0 ± 1
Methane (CH ₄)	0 ± 0
Ethanol (EtOH)	4 ± 5
Hydrogen (H ₂)	70 ± 26

Table 7-8. HYDROGEN SULFIDE (appropriate models only) - Typical Performance Specifications

RANGE	200 ppm H ₂ S
RESOLUTION	1 ppm H ₂ S
REPRODUCIBILITY	±2 ppm H ₂ S or 10% of reading, whichever is greater
RESPONSE TIME	90% of final reading in 40 seconds* (normal temperature range)

*See TABLE 7-2, NOTE 1.

Table 7-9. HYDROGEN SULFIDE - Cross Reference Factors for Orion Calibration Using Calibration Cylinder (P/N 804769) or (P/N 804770) Set to 10 ppm H₂S

NOTE: Data is presented as the indicated output in ppm, which would result from the application of 100 ppm of the test gas.

TEST GAS (100 PPM)	EQUIVALENT PPM
Hydrogen Sulfide (H ₂ S)	100 ±10
Ethylene (C ₂ H ₄)	0 ±0
Methane (CH ₄)	0 ±0
Hydrogen (H ₂)	0 ±0
Ammonia (NH ₃)	0 ±0
Chlorine (Cl ₂)	0 ±0
Nitrogen Dioxide (NO ₂)	-20 ±2
Nitric Oxide (NO)	1 ±1
Carbon Monoxide (CO)	0 ±0
Hydrogen Chloride (HCl)	0 ±0
Hydrogen Cyanide (HCN)	1 ±1
Sulfur Dioxide (SO ₂)	10 ±3
Ethanol (EtOH)	0 ±0
Toluene	0 ±0

Chapter 8

Replacement and Accessory Parts

Table 8-1. Accessory Parts List

PART	PART NO.
Calibration Cap	10020550
Probe - 1 ft.	800332
Probe - 3 ft.	800333
Sampling Line - 5 ft.	497332
Sampling Line - 10 ft.	497333
Sampling Line - 15 ft.	497334
Sampling Line - 25 ft.	497335
Replacement Filter, Probe (pkg. of 10)	801582
Aspirator Assembly	10020545
Protective Jacket, Orange Nylon	10020486
Protective Rubber Boot, Black	10022036
Protective Rubber Boot, Red (North American-approved instrument only)	10025665
Leather Carrying Case	10020485
Calibration Kit Model RP with 0.25 lpm Regulator	477149
Calibration Gas - 58% LEL pentane simulant / 15% O ₂	478192
Calibration Gas - 58% LEL pentane simulant / 15% O ₂ ; 300 ppm CO	10010162
Calibration Gas - 58% LEL pentane simulant / 15% O ₂ ; 10 ppm H ₂ S	804769
Calibration Gas - 58% LEL pentane simulant / 15% O ₂ ; 300 ppm CO and 10 ppm H ₂ S	804770
Bump Test Kit	813411
Squirt Gas, 52% LEL Pentane/15% O ₂ /60 ppm CO	814497
Squirt Gas, 52% LEL Pentane/15% O ₂	815308
Squirt Gas, 52% LEL Pentane/15% O ₂ /300 ppm CO/35 ppm H ₂ S	814559
Gas Miser Regulator, Model RP	710288
Regulator, .25 LPM, Model RP	467895
Regulator, Combination, .25 LPM, Model RP	711175
Battery Charger, NiMH, A.C.	10020551
Battery Charger, NiMH, Vehicle	10026502
Battery Pack, NiMH	10020502
Battery Pack, Alkaline	10020577
Belt Clip	10025664
English Text Keypad Overlay	10027170
Icon Keypad Overlay	10022098

Table 8-2. Replacement Parts List

FIGURE 8-1 OR 8-2 ITEM NO.	PART/COMPONENT	PART NO.
1	Pump Cap Assembly, includes screw P/N 10025551 (pumped version only)	10025539
2	Pump Cap Screw (pumped version only)	10025551
3	Case Screws	10022921
4	Sensor Cover (pumped version only)	10022105
	Sensor Cover (diffusion version only)	10026032
5	Sensor Membrane	10022104
6	Sensor Cover Gasket	10022096
7	Oxygen Sensor	10025940
8	Hydrogen Sulfide Sensor	711307
9	Combustible Sensor	10024247
10	Carbon Monoxide Sensor	711306
11	Sensor Gasket	10022331
12	Front Case Assembly (non-saleable)	10026268
13	Pump Cap Assembly, includes gasket P/N 10022102 (pumped version only)	10025539
14	Pump Cap Gasket	10022102
15	Display Assembly	10020548
16	Printed Circuit Board Assembly, Main	10020362
17	LINK Printed Circuit Board Assembly	
18	Case Gasket	10022100
19	Pump and Drive Replacement Kit	10026031
20	Filter Disc	655552
21	Dust filter, package of five	808935
22	Inlet Fitting	497187
23	Filter Cover	811722
24	Filter Cover Screws	10022922
25	Case Rear, Pumped (pumped version only) (non-saleable)	10026300
	Case Rear, Diffusion (diffusion version only) (non-saleable)	10026269
26	Filter Cover O-ring	637009
27	Internal backup filter (not shown)	634261

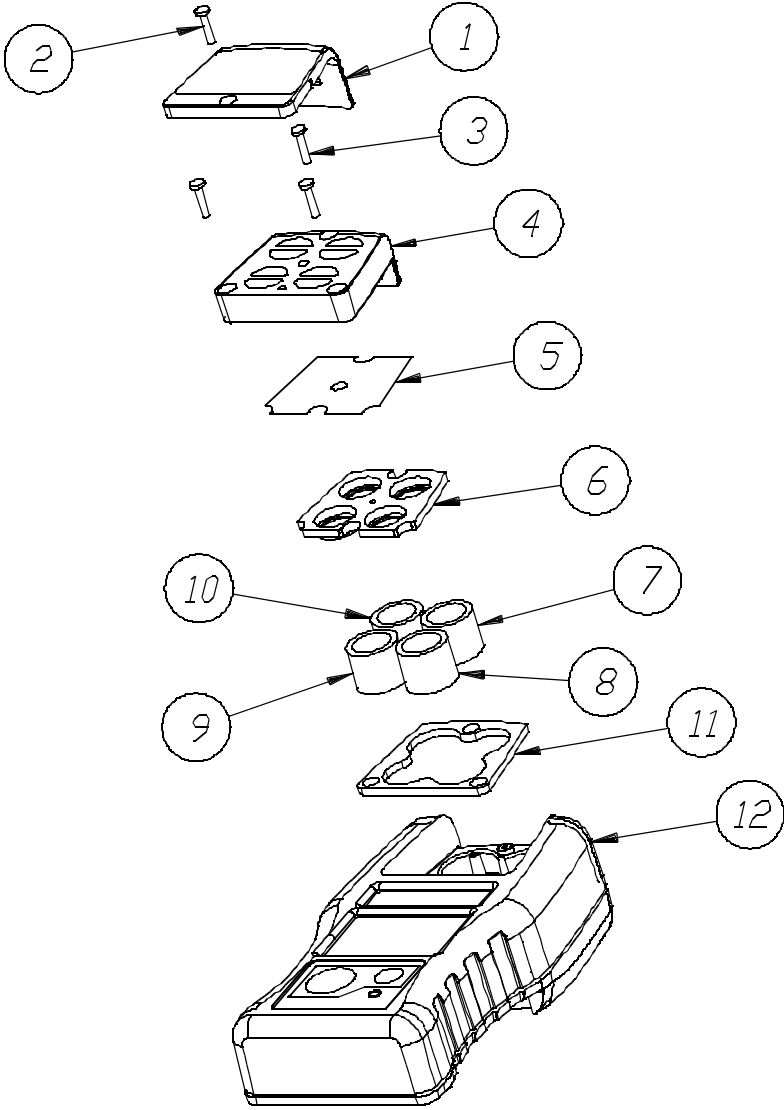

Figure 8-1. Replacement Parts (see Table 8-2)

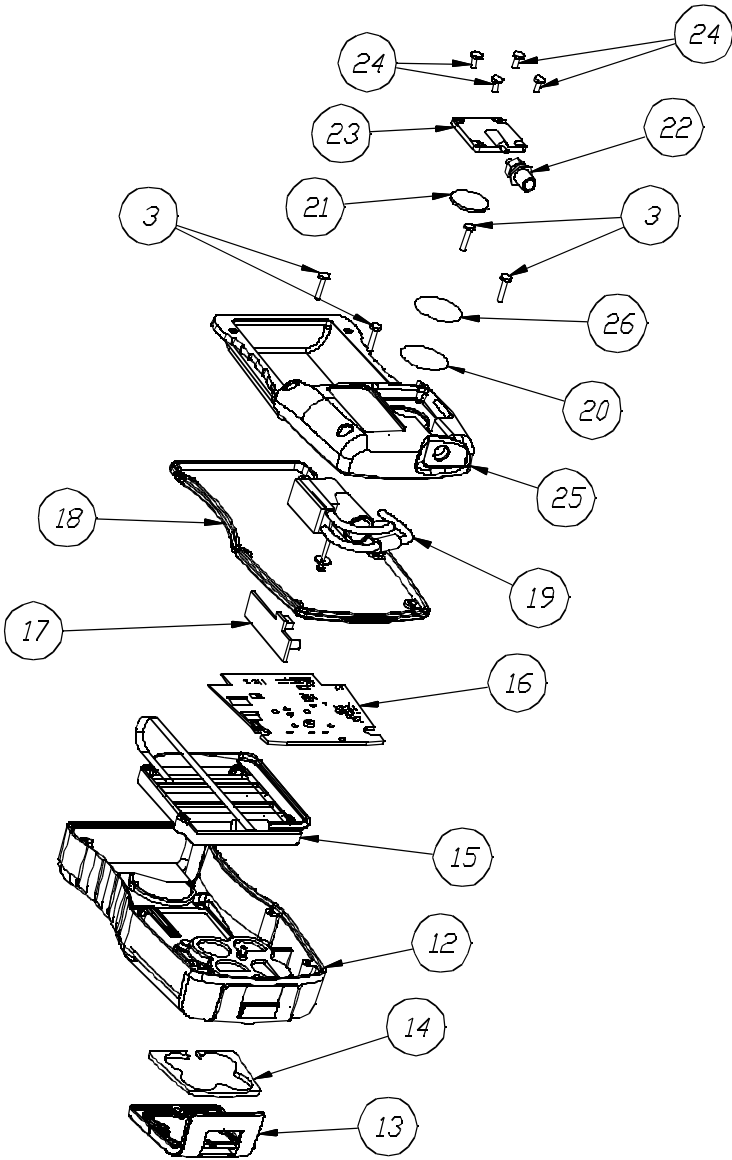

Figure 8-2. Replacement Parts (see Table 8-2)