

MSA Sirius™ MultiGas Detector

Operating Manual



In North America, to contact your nearest stocking location, dial toll-free 1-800-MSA-2222
To contact MSA International, dial 1-412-967-3354 or 1-800-MSA-7777

© MINE SAFETY APPLIANCES COMPANY 2005 - All Rights Reserved

This manual is available on the internet at www.msanet.com

Manufactured by

MSA INSTRUMENT DIVISION

P.O. Box 427, Pittsburgh, Pennsylvania 15230

WARNING

THIS MANUAL MUST BE CAREFULLY READ BY ALL INDIVIDUALS WHO HAVE OR WILL HAVE THE RESPONSIBILITY FOR USING OR SERVICING THE PRODUCT. Like any piece of complex equipment, this instrument will perform as designed only if it is used and serviced in accordance with the manufacturer's instructions. OTHERWISE, IT COULD FAIL TO PERFORM AS DESIGNED AND PERSONS WHO RELY ON THIS PRODUCT FOR THEIR SAFETY COULD SUSTAIN SEVERE PERSONAL INJURY OR DEATH.

The warranties made by Mine Safety Appliances Company with respect to the product are voided if the product is not used and serviced in accordance with the instructions in his manual. Please protect yourself and others by following them. We encourage our customers to write or call regarding this equipment prior to use or for any additional information relative to use or repairs.

Table of Contents

Chapter 1, Instrument Safety and Certifications1-1

▲ WARNING	1-1
Safety Limitations and Precautions	1-2
▲ WARNING	1-2
Date of Instrument Manufacture	1-4
Certifications	1-4
Electronic Interference	1-4

Chapter 2, PID Theory and Definitions2-1

PID Theory	2-1
Figure 2-1. Typical Photoionization Sensor Design .2-1	2-1
Zero Gas	2-2
Span Gas	2-2
Response Factors	2-2
▲ WARNING	2-2
Calculating a Response Factor	2-3
▲ WARNING	2-4

Chapter 3, Using the Sirius Multigas Detector3-1

Figure 3-1. Instrument Features	3-1
Figure 3-2. Understanding the Display	3-2
Turning ON the Sirius Multigas Detector	3-3
Last Cal Date	3-3
Fresh Air Set Up Option	3-4
▲ WARNING	3-4
Battery Life Indicator (FIGURE 3-3)	3-5
Battery Warning	3-5
Battery Shutdown	3-5
Figure 3-3. Battery Indicator	3-5
Sensor Missing Alarm	3-6
▲ CAUTION	3-6
▲ WARNING	3-6

▲ WARNING	3-6
PID Alarms	3-7
PID Bulb -Cal Now	3-7
▲ WARNING	3-7
Verifying Pump Operation	3-8
Figure 3-4a. Pump Alarm on the Display	3-8
Figure 3-4b. Pump Alarm on the Display	3-8
To Clear an Alarm	3-9
Calibration Check	3-9
▲ WARNING	3-9
Measuring Gas Concentrations	3-10
Combustible gases (% LEL) (FIGURE 3-5)	3-10
Figure 3-5a. Instrument in LEL Alarm	3-10
▲ WARNING	3-11
Figure 3-5b. Instrument in LEL Alarm	3-11
Oxygen Measurements (% O2) (FIGURE 3-6)	3-12
Figure 3-6a. Instrument in Oxygen Alarm	3-12
Figure 3-6b. Instrument in Oxygen Alarm	3-12
Toxic Gas and VOC Measurements (FIGURE 3-7)	3-13
▲ WARNING	3-13
Figure 3-7a. Instrument in VOC Gas Alarm	3-13
Confidence Flash	3-14
▲ WARNING	3-14
Figure 3-7b. Instrument in VOC Gas Alarm	3-14
Safe LED	3-15
Operating Beep	3-15
Figure 3-8. Heartbeat	3-15
Viewing Optional Displays (FIGURE 3-9)	3-16
Figure 3-9. Flow Diagram	3-16
Peak Readings (PEAK) (FIGURE 3-10)	3-17
Minimum Readings (MIN) (FIGURE 3-11)	3-17
Figure 3-10. PEAK Readings on the Display	3-17
Figure 3-11. MIN Reading on the Display	3-17
Short Term Exposure Limits (STEL) (FIGURE 3-12)	3-18
To Reset the STEL:	3-18
Figure 3-12. Exposure Page with STEL Alarm	3-18
Time Weighted Average (TWA) (FIGURE 3-13)	3-19
▲ WARNING	3-19
Figure 3-13. Exposure Page with TWA Alarm	3-19

To Reset the TWA:	3-20.
▲ WARNING	3-20
Time and Date Display (FIGURE 3-14)	3-21
PID Setup	3-21
Displaying Current Response Factor	3-21
Figure 3-14 Time Display	3-21
▲ WARNING	3-21
Changing Response Factor	3-22
Selecting a Custom Response Factor	3-22
Figure 3-15. PID RF Page	3-22
Changing PID Bulb Selection	3-23
Figure 3-14. Changing PID Bulb Selection	3-23
▲ WARNING	3-24
Benzene Scrubber Procedure for Sirius PID (only if equipped with 9.8 eV lamp)	3-24
Turning OFF the Sirius Multigas Detector	3-25

Chapter 4, Setting up the Sirius Multigas Detector . . . 4-1

▲ WARNING	4-1
Power Systems	4-1
Table 4-1. Battery Type/Temperature/ Approximate Run Time (Hours)	4-1
Table 4-2. Battery Type/Temperature Class	4-1
Battery Pack Removal and Replacement	4-1
Figure 4-1. Battery Pack Removal	4-2
Figure 4-2. Changing Alkaline Batteries	4-2
Battery Charging (Lithium-Ion Battery Pack Only) ..	4-3
To Charge the Instrument	4-3
▲ CAUTION	4-3
Changing Instrument Settings	4-4
Accessing the Instrument Setup Mode	4-4
Figure 4-3.. Entering the Set-up Mode	4-5
Instrument Alarm Bypass Options	4-6
▲ WARNING	4-8
▲ WARNING	4-9
▲ WARNING	4-9

Chapter 5, Calibration5-1

▲ WARNING5-1
Calibrating the Sirius Multigas Detector5-1
 Table 5-1. Autocalibration and
 Required Calibration Cylinders5-1
 To Calibrate the Sirius Multigas Detector5-2
 Figure 5-1. Calibration Flow Chart5-2
 Figure 5-2a. Zero Flag5-3
 Figure 5-2b. Zero Flag5-3
 Figure 5-3a. CAL Flag5-4
 Figure 5-3b. CAL Flag5-4
Autocalibration Failure5-5

**Chapter 6, Warranty, Maintenance, and
Troubleshooting6-1**

MSA Portable Instrument Warranty6-1
Cleaning and Periodic Checks6-2
 Removing and Cleaning the PID Bulb6-2
 ▲ WARNING6-2
 ▲ WARNING6-2
 Cleaning Steps6-3
 ▲ CAUTION6-3
 ▲ CAUTION6-3
 Figure 6-1. Cleaning the PID Bulb6-4
 ▲ WARNING6-4
 Replacing the Ion Chamber6-5
 ▲ CAUTION6-5
 ▲ WARNING6-5
 Figure 6-2a. Ion Chamber Removal6-6
 ▲ CAUTION6-6
 Figure 6-2b. Ion Chamber Removal6-7
 Figure 6-3a. Ion Chamber Housing Cleaning6-8
 Figure 6-3b. Ion Chamber Cleaning6-8
 Replacing the Filters6-9
 Dust AND WATER Filter6-9
 Figure 6-4. Ion Chamber Installation6-9
 ▲ CAUTION6-9
 ▲ WARNING6-9

Figure 6-5. Filter Installation	6-10
Figure 6-6. Case Oval-shaped O-ring	6-10
Probe Filter	6-11
▲ WARNING	6-11
Figure 6-7. Replacing the Probe Filter	6-11
Storage	6-12
Shipment	6-12
Troubleshooting	6-12
▲ WARNING	6-12
Table 6-1. Troubleshooting Guidelines	6-13
Sensor Replacement	6-13
Figure 6-8. Sensor Locations	6-14
Replacement of the Electronics Boards, the Display Assembly, the Horn Assembly, and the Pump	6-15
▲ WARNING	6-15
▲ WARNING	6-15

Chapter 7, Performance Specifications . . . 7-1

Table 7-1. Certifications (see instrument label to determine applicable approval)	7-1
Table 7-2. Instrument Specifications	7-1
Table 7-3. COMBUSTIBLE GAS - Typical Performance Specifications	7-2
Table 7-4. COMBUSTIBLE GAS - Cross Reference Factors for Sirius General-Purpose Calibration Using Calibration Cylinder (P/N 10045035) Set to 58% LEL Pentane Simulant	7-2
Table 7-5. OXYGEN - Typical Performance Specifications	7-4
Environment and Oxygen Sensor Readings	7-4
Pressure Changes	7-4
Humidity Changes	7-4
Temperature Changes	7-5
Table 7-6. CARBON MONOXIDE (appropriate models only) - Typical Performance Specifications	7-5
Table 7-7. CARBON MONOXIDE - Cross Reference Factors for Sirius Calibration Using Calibration Cylinder (P/N 10045035)	7-6

Table 7-8. HYDROGEN SULFIDE (appropriate models only) - Typical Performance Specifications	7-7
Table 7-9. HYDROGEN SULFIDE - Cross Reference Factors for Sirius Calibration Using Calibration Cylinder (P/N10045035)	7-7
Table 7-10. PID (appropriate models only) - Typical Performance Specifications	7-8
Table 7-11. PID Response Factor Table	7-9
▲ WARNING	7-13
▲ WARNING	7-13
▲ WARNING	7-13
Table 7-12. Known Interference Data for listed VOCs	7-14
▲ WARNING	7-14
▲ WARNING	7-15

Chapter 8, Replacement and Accessory Parts8-1

Table 8-1. Accessory Parts List	8-1
Table 8-2. Replacement Parts List	8-3

Chapter 1, Instrument Safety and Certifications

The Sirius Multigas Detector is for use by trained and qualified personnel. It is designed to be used when performing a hazard assessment to:

- Assess potential worker exposure to combustible and toxic gases and vapors
- Determine the appropriate gas and vapor monitoring needed for a workplace.

The Sirius Multigas Detector can be equipped to detect:

- Combustible gases and certain combustible vapors
- Volatile organic compounds (VOCs)
- Oxygen-deficient or oxygen-rich atmospheres
- Specific toxic gases for which a sensor is installed.

WARNING

- **Read and follow all instructions carefully.**
- **Check calibration before each day's use and adjust if necessary.**
- **Check calibration more frequently if exposed to silicone, silicates, lead-containing compounds, hydrogen sulfide, or high contaminant levels.**
- **Recheck calibration if unit is subjected to physical shock.**
- **Use only to detect gases/vapors for which a sensor is installed.**
- **Do not use to detect combustible dusts or mists.**
- **Make sure adequate oxygen is present.**
- **Do not block pump sample inlet.**
- **Use only Teflon sampling lines for reactive gases such as Cl₂, PH₃, NH₃, HCN, and for semivolatile organic compounds such as gasoline and jet fuels.**
- **Use only MSA-approved sampling lines.**
- **Do not use silicone tubing or sampling lines.**
- **Wait sufficient time for the reading; response times vary, based on gas/vapor and length of sampling line.**

- Have a trained and qualified person interpret instrument readings.
- Account for sensor reproducibility.
- Properly identify the VOC gas being measured before using VOC response factors or setting alarm values (exposures, STEL, TWA).
- Recognize that the VOC Auto-range displays readings in increments of 100 ppb.
- Ensure installed PID bulb corresponds to the PID bulb setting on the instrument display.
- Do not remove battery pack from instrument while in a hazardous atmosphere.
- Do not take spare battery packs into a hazardous atmosphere. Battery packs must be properly attached to the instrument at all times.
- When they are to be discarded, properly dispose of alkaline cells and the Li-Ion battery pack.
- Do not recharge Lithium Ion battery or change Alkaline batteries in a hazardous location.
- Do not alter or modify instrument.

INCORRECT USE CAN CAUSE SERIOUS PERSONAL INJURY OR DEATH.

Safety Limitations and Precautions

⚠ WARNING

It is very important to have an understanding of PID basics when changing your PID settings. Failure to properly identify the VOC gas being measured and/or failure to select the correct Response Factor alarm values (exposure, STEL, TWA) that match your desired Response Factor and/or the correct bulb, will result in erroneous readings that could lead to serious injury or death.

Carefully review the following safety limitations and precautions before placing this instrument in service:

- The Sirius Multigas Detector is designed to:
 - Detect gases and vapors in air only
 - Detect only specified toxic gases for which a sensor is installed.
- Perform the following check before each day's use to verify proper instrument operation:
 - Calibration check (see Calibration Check section). Adjust calibration if the readings are not within the specified limits.

- Check calibration more frequently if the unit is subjected to physical shock or high levels of contaminants. Also, check calibration more frequently if the tested atmosphere contains the following materials, which may desensitize the combustible gas sensor and/or VOC sensor (PID) and reduce its readings:
 - Organic silicones
 - Silicates
 - Lead-containing compounds
 - Hydrogen sulfide exposures over 200 ppm or exposures over 50 ppm for one minute.
- The minimum concentration of a combustible gas in air that can ignite is defined as the Lower Explosive Limit (LEL). A combustible gas reading of "100" (in LEL mode) or "5.00" (in CH₄ mode) indicates the atmosphere is at 100% LEL or 5.00% CH₄ (by volume), respectively, and an explosion hazard exists. In such cases, the instrument LockAlarm feature activates. Move away from contaminated area immediately.
- Do not use the Sirius Multigas Detector to test for combustible or toxic gases in the following atmospheres as this may result in erroneous readings:
 - Oxygen-deficient or oxygen-rich (greater than 21% by volume) atmospheres
 - Reducing atmospheres
 - Furnace stacks
 - Inert environments
 - Atmospheres containing combustible airborne mists/dusts
 - Ambient pressures other than one atmosphere.
- Do not use the Sirius Multigas Detector to test for combustible gases in atmospheres containing vapors from liquids with a high flash point (above 38°C, 100°F) as this may result in erroneously low readings.
- Allow sufficient time for unit to display accurate reading. Response times vary based on the type of sensor being utilized (see Chapter 7, **Performance Specifications**).
- All instrument readings and information must be interpreted by someone trained and qualified in interpreting instrument readings in relation to the specific environment, industrial practice and exposure limitations.
- Replace alkaline batteries in non-hazardous areas only. Use only batteries listed on the approval label.

- Recharge the battery in non-hazardous area only. Use only battery chargers listed in this manual; other chargers may damage the battery pack and the unit. Dispose of batteries in accordance with local health and safety regulations.
- Do not alter this instrument or make any repairs beyond those specified in this manual. Only MSA-authorized personnel may repair this unit; otherwise, damage may result.

Date of Instrument Manufacture

The date of manufacture of your Sirius Multigas Detector is coded into the instrument serial number.

- The last three digits represent the month (the letter) and the year (the two-digit number).
- The letter corresponds to the month starting with A for January, B for February, etc.

Certifications

Tests completed by MSA verify that the Sirius Multigas Detector meets applicable industry and government standards as of the date of manufacture. See TABLE 7-1.

Electronic Interference

- This instrument generates, uses, and can radiate radio frequency energy. Operation of this instrument may cause interference, in which case, the user may be required to correct.
- This device is test equipment and is not subject to FCC technical regulations. However, it has been tested and found to comply with the limits for a Class A digital device specified in Part 15 of the FCC regulations.
- This digital apparatus does not exceed the Class A limits for radio noise emissions from digital apparatus set out in the Radio Interference Regulations of the CRTC.
- There is no guarantee that interference will not occur. If this instrument is determined to cause interference to radio or television reception, try the following corrective measures:
 - Reorient or relocate the receiving antenna
 - Increase separation between the instrument and the radio/TV receiver
 - Consult an experienced radio/TV technician for help.

Chapter 2, PID Theory and Definitions

To support the safe and effective operation of the Sirius Multigas Detector, MSA believes operators should have a working knowledge of how the instrument functions, not just how to make it work. The information presented in this section supplements the hands-on operational instruction provided in the rest of the manual for the PID.

PID Theory

A photoionization detector (PID) uses an ultraviolet lamp to ionize the compound of interest. A current is produced and the concentration of the compound is displayed in parts per million on the instrument meter.

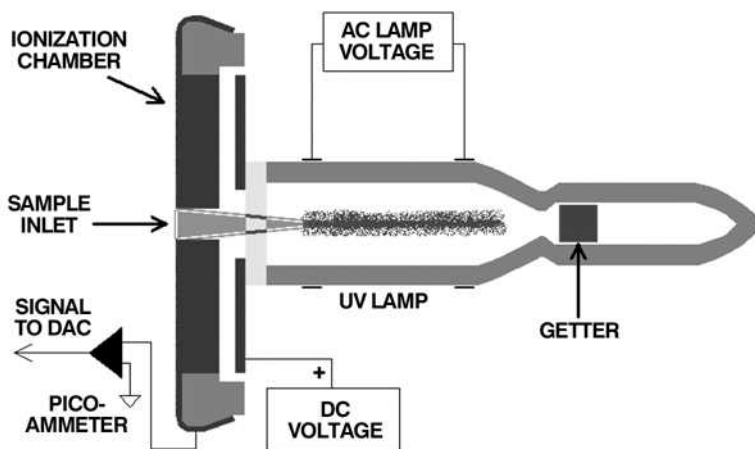

Figure 2-1. Typical Photoionization Sensor Design

Zero Gas

Zero gas is a reference gas used during calibration to zero the instrument. When a zero gas with no hydrocarbon content is introduced to the monitor, the detector will still respond with a small signal. This signal is a result of secondary background processes. During calibration, zero gas is applied to quantify the background ionization current.

For applications in which you are only interested in concentration changes relative to a reference ambient environment, fresh air can be used as the zero gas. When background hydrocarbon vapors are present, MSA recommends using zero gas air or a carbon filter on the inlet to zero the unit (See Chapter 8, TABLE 8-1, **Accessory Parts List**).

Span Gas

Span gas is a reference gas used during calibration to determine the slope (response per unit concentration) of the calibrated response curve.

Span Gas Recommendation: MSA strongly recommends use of an MSA 100 ppm isobutylene cylinder for calibration. See Chapter 5, **Calibration** for calibration instructions.

Response Factors

When a compound is ionized by a photoionization detector, it yields a current. This response is a characteristic property of the specific compound which is influenced by its molecular structure. The slope of the response curve (defined in picoamperes per ppm) is different for different chemicals. To properly report the concentration for a given sample gas, the Sirius Multigas Detector uses response factors. See Chapter 3, **Using the Sirius Multigas Detector - PID Setup**, for instructions on using the pre-programmed list of response factors.

WARNING

It is very important to have an understanding of PID basics when changing your PID settings. Failure to properly identify the VOC gas being measured and/or failure to select the correct Response Factor alarm values (exposure, STEL, TWA) that match your desired Response Factor and/or the correct bulb, will result in erroneous readings that could lead to serious injury or death.

The response factor is defined as the ratio of the detector response for isobutylene to the detector response for the sample gas. Response factors for a wide range of substances have been determined experimentally. These response factors are programmed into the instrument. Note that the calibrated response curve, and all programmed response factors are relative to isobutylene. (Isobutylene has a response factor of one.)

The response factor is a multiplier that compensates for the difference between the response of the sample gas and the response of isobutylene. Whenever the monitor detects a signal, it uses the response factor for that chemical to convert the signal to the correct, displayed concentration of the sample gas (if its identity is known). During calibration, this calculation is performed to define the calibrated response curve. When sampling, the isobutylene equivalent response is then multiplied by the response factor for the specific sample gas to calculate the concentration.

If the response factor is known, you can use a monitor calibrated on isobutylene to calculate the actual concentration of a target gas.

For example:

An operator is using a monitor that has been calibrated on isobutylene. The sample gas is set to isobutylene. While using this instrument to sample for hydrogen sulfide (H₂S), the display reads 100 ppm. Since the response factor for hydrogen sulfide is 3.46, the actual concentration of hydrogen sulfide is:

Actual Hydrogen Sulfide concentration = 3.46 x 100 ppm = 346 ppm.

Calculating a Response Factor

To determine a response factor for a target chemical, perform the following simple procedure:

1. Calibrate the Sirius Detector using isobutylene as the span gas.
2. On the monitor, set the sample gas name to isobutylene.
3. Apply a known concentration of the target chemical to the monitor and note the concentration reported in the display.
4. The response factor for the target chemical relative to isobutylene:

$$RF \text{ target gas} = \frac{\text{Actual known concentration}}{\text{Concentration reported by instrument}}$$

For example:

A monitor is calibrated on isobutylene, and has isobutylene defined as the sample gas. When sampling 106 ppm of benzene in air, the instrument reports a concentration of 200 ppm. In this example, the response factor for benzene relative to isobutylene would be:

$$RF_{\text{benz}} = \frac{106 \text{ ppm known conc. benzene}}{200 \text{ ppm reported}} = 0.53$$

When surveying, if benzene is selected as the sample gas in the Response Factor page, and 0.53 is entered into the monitor as the response factor, the instrument would use this response factor to automatically correct the displayed concentration into PPM benzene.

If a chemical has a response factor between zero and one, the monitor has a higher detector response for this chemical than isobutylene. If the response factor is greater than one, the monitor has a lower detector response for this chemical than isobutylene.

WARNING

It is very important to select the correct bulb setting during PID setup since PID response factors for a target chemical relative to Isobutylene are different depending on what energy PID bulb is installed. See Chapter 3, "Using the Sirius Multigas Detector" for setup instructions. Failure to follow this warning can result in inaccurate readings that could lead to serious injury or death.

Chapter 3, Using the Sirius Multigas Detector

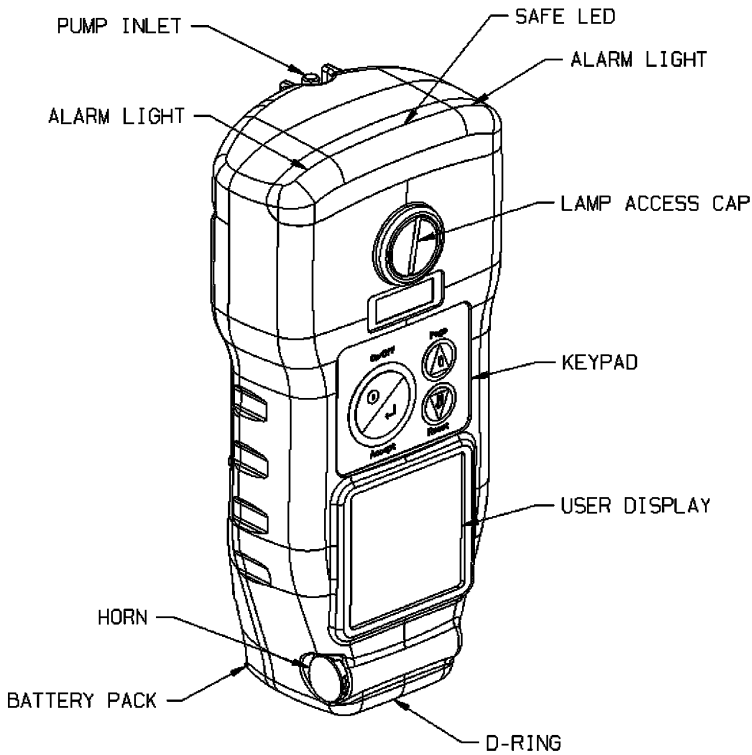

Figure 3-1. Instrument Features

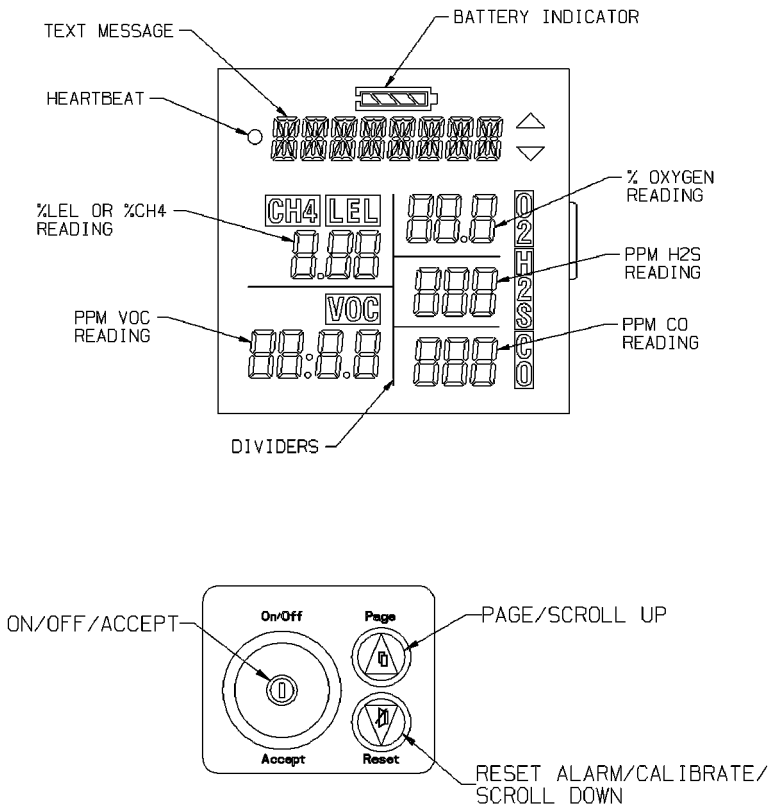

Figure 3-2. Understanding the Display

Turning ON the Sirius Multigas Detector

Press the Power ON button; the instrument displays:

1. A self-test:
 - All segments display
 - Audible alarm sounds
 - Alarm LEDs illuminate
 - Display backlight illuminates
 - Pump activates
 - Software version displays
 - Internal diagnostics.
2. Alarm setpoints:
 - Low
 - High
 - STEL (if activated)
 - TWA (if activated)
3. Calibration gas (expected calibration gas values)
4. Time and date (if data logging option installed)
5. Last CAL date (if data logging option installed)
6. Instrument warm-up period
7. Fresh Air Setup option.

Last Cal Date

The Sirius Multigas Detector is equipped with a “last successful calibration date” feature. The date shown is the last date that all installed sensors were successfully calibrated. "**LAST CAL**" is displayed with this date in the following format:

- **MM/DD/YY**

Fresh Air Set Up Option

(for automatic zero adjustment of the Sirius Multigas Detector sensors)

NOTE: The Fresh Air Setup (FAS) has limits. If a hazardous level of gas is present, the Sirius Multigas Detector ignores the FAS command and goes into alarm.

WARNING

Do not activate the Fresh Air Setup unless you are certain you are in fresh, uncontaminated air; otherwise, inaccurate readings can occur which can falsely indicate that a hazardous atmosphere is safe. If you have any doubts as to the quality of the surrounding air, do not use the Fresh Air Setup feature. Do not use the Fresh Air Setup as a substitute for daily calibration checks. The calibration check is required to verify span accuracy. Failure to follow this warning can result in serious personal injury or death.

Persons responsible for the use of the Sirius Multigas Detector must determine whether or not the Fresh Air Setup option should be used. The user's abilities, training and normal work practices must be considered when making this decision.

1. Turn ON the Sirius Multigas Detector.
 - Once the instrument self check is complete, **ZERO?** flashes for 10 seconds.
2. To perform a Fresh Air Setup, push the ON/OFF button while **ZERO?** is flashing.
3. To immediately skip the FAS, push the RESET/▼ button.
 - If no buttons are pushed, the **ZERO?** automatically stops flashing after the 10 seconds have expired and the FAS is not performed.



Figure 3-3. Battery Indicator

Battery Life Indicator (FIGURE 3-3)

- The battery condition icon continuously displays in the upper portion of the screen, regardless of the selected page.
- As the battery charge dissipates, segments of the battery icon go blank until only the outline of the battery icon remains.

Battery Warning

- A Battery Warning indicates that a nominal 15 minutes of operation remain before instrument batteries are completely depleted.

NOTE: Duration of remaining instrument operation during Battery Warning depends on ambient temperatures.

- When the Sirius Multigas Detector goes into Battery Warning:
 - Battery Life indicator flashes
 - “BATT WRN” flashes every 15 seconds
 - Alarm sounds
 - Lights flash every 15 seconds
 - The Sirius Multigas Detector continues to operate until the instrument is turned OFF or battery shutdown occurs.

Battery Shutdown

When the batteries can no longer operate the instrument, the instrument goes into Battery Shutdown mode:

- **LOW** and **BATTERY** flash on the display

- Alarm sounds and lights flash
- Alarm can be silenced by pressing the RESET/▼ button
- No other pages can be viewed
- After approximately one minute, the instrument automatically turns OFF.

▲ WARNING

When Battery Shutdown condition sounds, stop using the instrument; it can no longer alert you of potential hazards since it does not have enough power to operate properly:

- 1. Leave the area immediately.**
- 2. Turn OFF the instrument if it is ON.**
- 3. Report to the person responsible for maintenance**
- 4. Recharge or replace the battery.**

Failure to follow this procedure could result in serious personal injury or death.

▲ CAUTION

During "Battery Warning" condition, prepare to exit the work area since the instrument could go into "Battery Shutdown" at any time, resulting in loss of sensor function. Depending on the age of the batteries, ambient temperature and other conditions, the instrument "Battery Warning" and "Battery Shutdown" times could be shorter than anticipated.

▲ WARNING

Recharge or replace the battery when the "Battery Warning" or "Battery Shutdown" conditions occur.

Recharging or replacing batteries must be done in a non-hazardous location only.

Sensor Missing Alarm

The Sirius Multigas Detector will enter the Sensor Missing alarm if the instrument detects that an enabled sensor is not properly installed in the instrument. For O₂, CO, and H₂S sensors, the Sensor Missing feature is checked when the instrument is turned ON and when leaving the Setup mode. The combustible Sensor Missing feature is continually monitored. If a sensor is detected as missing, the following occurs:

- **SENSOR** and **MISSING** flash on the display
- The flag above the sensor detected as missing flashes on the display

- Alarm sounds and lights flash
- Alarm can be silenced by pressing the RESET/▼ button
- No other pages can be viewed
- After approximately one minute, the unit automatically turns OFF.

PID Alarms

The Sirius Multigas Detector will enter the Ion Error, PID Error, PID Failed Span Cal, or the PID Comm Error if the instrument detects that the PID is not functioning properly.

The Ion Error, PID Error, and PID Comm features are continually monitored. The PID Failed Span Cal is monitored during calibration only. If one of these errors is detected, the following occurs:

- The error name flashes on the display
- Alarm sounds and lights flash
- Alarm can be silenced by pressing the RESET/▼ button
- No other pages can be viewed
- After approximately one minute, the unit automatically turns OFF.

See Chapter 6, **Troubleshooting** for corrective action guidelines.

PID Bulb -Cal Now

This message may appear in the event that the instrument detects a potential problem with the output of the PID sensor. When this occurs, the best course of action is to clean the PID bulb (see Chapter 5, **Calibration**). This message is not a replacement for daily bump checks.

WARNING

If a Sensor Missing, PID Error, Ion Error, PID Failed Span Cal, or PID Comm condition occurs, stop using the instrument; it can no longer alert you of potential hazards.

- 1. Leave the area immediately.**
- 2. Turn OFF the instrument if it is ON.**
- 3. Report to the person responsible for maintenance**

Failure to follow this procedure could result in serious personal injury or death.

Verifying Pump Operation

1. Turn ON the Sirius Multigas Detector.
 - The pump motor starts fast and then slows down as the instrument adjusts the power to run the pump.
2. Once gas readings are displayed, plug the free end of the sampling line or probe.
 - The pump motor shuts down and an alarm sounds (FIGURE 3-4)
 - PUMP ALARM will flash on the display
 - The readings on the display may change.



Figure 3-4a. Pump Alarm on the Display



Figure 3-4b. Pump Alarm on the Display

3. When the pump inlet, sample line or probe is blocked, the pump alarm must activate. If the alarm does not activate:
 - a. Check the sample line and probe for leaks.
 - b. Once leak is fixed, recheck pump alarm by blocking the flow.
4. Check the pump before each day's use

⚠ WARNING

Perform a blocked flow test before each day's use. Do not use the pump, sample line, or probe unless the pump alarm activates when the flow is blocked. Lack of an alarm is an indication that a sample may not be drawn to the sensors, which could cause inaccurate readings. Failure to follow the above can result in serious personal injury or death.

Never let the end of the sampling line touch or go under any liquid surface. If liquid is sucked into the instrument, readings will be inaccurate and the instrument could be damaged. We recommend the use of an MSA Sample Probe (P/N 10042621, 10042622, 10040589, or equivalent) containing a special membrane filter, permeable to gas but impermeable to water, to prevent such an occurrence.

5. Press the RESET/▼ button to reset the alarm and restart the pump.

During operation, a pump alarm may occur when the:

- Flow system is blocked
- Pump is inoperative
- Sample lines are attached or removed.

To Clear an Alarm

1. Correct any flow blockage.
2. Press the RESET/▼ button.
 - The Pump will now restart.

NOTE: When the instrument is in a gas alarm, the pump alarm may not display until gas alarm is cleared.

Calibration Check

The calibration check is simple and should only take about one minute. Perform this calibration check before each day's use for each installed sensor.

1. Turn ON the Sirius Multigas Detector in clean, fresh air.
2. Verify that readings indicate no gas is present.
3. Attach regulator (supplied with calibration kit) to the cylinder.
4. Connect tubing (supplied with calibration kit) to the regulator.
5. Attach other end of tubing to the instrument.
6. Open the valve on the regulator, if so equipped.
 - The reading on the Sirius Multigas Detector display should be within the limits stated on the calibration cylinder or limits determined by your company.
 - If necessary, change cylinder to introduce other calibration gases.
 - If readings are not within these limits, the Sirius Multigas Detector requires recalibration. See Chapter 5, **Calibration**.

NOTE: The presence of other calibration gases may cause the PID to underrange, indicated by dashes for the displayed VOC reading.

Measuring Gas Concentrations

Combustible Gases (% LEL) (FIGURE 3-5)



Figure 3-5a. Instrument in LEL Alarm



Figure 3-5b. Instrument in LEL Alarm

The Sirius Multigas Detector can be equipped to detect combustible gases in the atmosphere.

- Alarms sound when concentrations reach:
 - Alarm Setpoint or
 - 100% LEL (Lower Explosive Limit), 5% CH₄.
- When the combustible gas indication reaches the Alarm Setpoint:
 - Alarm sounds
 - Alarm lights flash
 - % LEL or CH₄ flag above the concentration flashes.
- To silence the alarm, press the RESET/▼ button.

NOTE: The alarm will stay silent if the alarm condition has cleared.

- When the combustible gas indication reaches 100% LEL or 5% CH₄, the LockAlarm™ circuit locks the combustible gas reading and alarm and:
 - Alarm sounds
 - Alarm lights flash
 - 100 (or 5.00 in CH₄ mode) appears on the display and flashes.
- This alarm cannot be reset with the RESET/▼ button.

▲ WARNING

If the 100% LEL or 5.00% CH₄ (by volume) alarm condition is reached, you may be in a life-threatening situation; there is enough gas in the atmosphere for an explosion to occur. In addition, any rapid up-scale reading followed by a declining or

erratic reading can also be an indication that there is enough gas for an explosion. If either of these indications occur, leave and move away from the contaminated area immediately. Failure to follow this warning can result in serious personal injury or death.

- After moving to a safe, fresh-air environment, reset the alarm by turning OFF the instrument and turning it ON again.

Oxygen Measurements (% O₂) (FIGURE 3-6)



Figure 3-6a. Instrument in Oxygen Alarm



Figure 3-6b. Instrument in Oxygen Alarm

The Sirius Multigas Detector can be equipped to detect the amount of oxygen in the atmosphere.

- Alarms can be set to trigger on two different conditions:
 - Deficiency/too little oxygen (setpoints less than 20.8)
 - Enriched/too much oxygen (setpoints greater than 20.8).
- When the alarm setpoint is reached for either of the above:
 - Alarm sounds
 - Alarm lights flash
 - % O₂ flag next to the concentration flashes.

⚠ WARNING

If the Oxygen alarm condition is reached while using the instrument as a personal or area monitor, leave the area immediately; the ambient condition has reached a preset alarm level. If using the instrument as an inspection device, do not enter the area without proper protection. Failure to follow this warning will cause exposure to a hazardous environment which can result in serious personal injury or death.

Toxic Gas and VOC Measurements (FIGURE 3-7)



Figure 3-7a. Instrument in VOC Gas Alarm



Figure 3-7b. Instrument in VOC Gas Alarm

- The Sirius Multigas Detector can be equipped to detect:
 - Carbon Monoxide (CO) and/or
 - Hydrogen Sulfide (H₂S) and/or
 - Volatile Organic Compounds (VOCs) in the atmosphere.
- When the alarm setpoint is reached for Carbon Monoxide (CO) and/or Hydrogen Sulfide (H₂S) and/or VOC:
 - Alarm Sounds
 - Alarm Lights flash
 - PPM CO or PPM H₂S or VOC flag flashes.

⚠ WARNING

If an alarm condition is reached while using the instrument as a personal or area monitor, leave the area immediately; the ambient condition has reached a preset alarm level. If using the instrument as an inspection device, do not enter the area without proper protection. Failure to follow this warning will cause over-exposure to toxic gases, which can result in serious personal injury or death.

Confidence Flash

In addition to the audible (brief horn sounding) and visual tests (all display segments light and all alarm lights flash) that occur when the instrument turns on, this instrument is equipped with a confidence heartbeat on the display that flashes periodically. This informs the user that the display is functioning normally (see FIGURE 3-8).



Figure 3-8. Heartbeat

Safe LED

The Sirius Multigas Detector is equipped with an optional green "SAFE" LED which flashes every 15 seconds under the following conditions

- The green SAFE LED is enabled
- Instrument is on the normal Measure Gases page
- Combustible reading is 0% LEL or 0%CH₄
- Oxygen (O₂) reading is 20.8%
- Carbon Monoxide (CO) reading is 0 ppm
- Hydrogen Sulfide (H₂S) reading is 0 ppm
- VOC reading is 0 ppm
- No gas alarms are present (low or high)
- Instrument is not in Low Battery warning or alarm
- CO, H₂S, VOC, STEL and TWA readings are 0 ppm.

Operating Beep

The Sirius Multigas Detector is equipped with an optional operating beep. This operating beep activates every 30 seconds by momentarily beeping the horn and flashing the alarm LEDs under the following conditions:

- Operating beep is enabled
- Instrument is on normal Measure Gases page
- Instrument is not in Battery warning
- Instrument is not in Gas alarm.

Viewing Optional Displays (FIGURE 3-9)

The FIGURE 3-9 diagram describes the flow for optional displays.

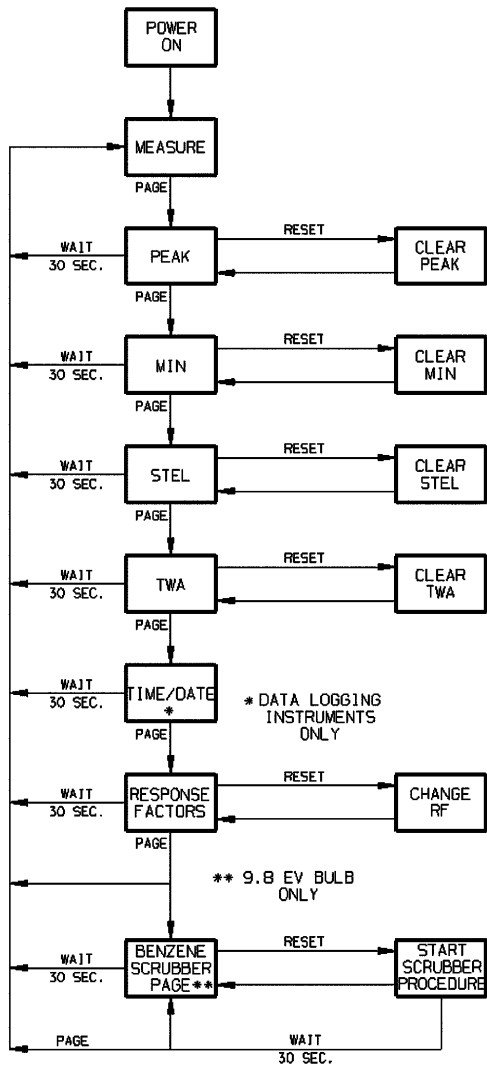

Figure 3-9. Flow Diagram

Press the PAGE/▲ button to move to the various screens.

NOTE: The page will default back to the Measure page within 30 seconds.

Press the PAGE/▲ button to move to:

Peak Readings (PEAK) (FIGURE 3-10)



Figure 3-10. PEAK Readings on the Display

- PEAK appears in the upper portion of the display to show the highest levels of gas recorded by the Sirius Detector since:
 - Turn-ON or
 - Peak readings were reset.
- To Reset the Peak Readings:
 1. Access the Peak page.
 2. Press the RESET/▼ button.

Minimum Readings (MIN) (FIGURE 3-11)



Figure 3-11. MIN Reading on the Display

- This page shows the lowest level of oxygen recorded by the Sirius Multigas Detector since:
 - Turn-ON or
 - MIN reading was reset.
- MIN appears in the upper portion of the display.
- To reset the MIN Reading:
 1. Access the Min page.
 2. Press the RESET/▼ button.

Short Term Exposure Limits (STEL) (FIGURE 3-12)



Figure 3-12. Exposure Page with STEL Alarm

- The STEL flag appear in the upper portion of the display to show the average exposure over a 15-minute period.
- When the amount of gas detected by the Sirius Multigas Detector is greater than the STEL limit:
 - Alarm sounds
 - Alarm lights flash
 - STEL flashes.

To Reset the STEL:

1. Access the STEL page.
2. Press the RESET/▼ button.

The STEL alarm is calculated over a 15-minute exposure. Calculation examples are as follows:

- Assume the Detector has been running for at least 15 minutes:
 - 15-minute exposure of 35 PPM:
$$\frac{(15 \text{ minutes} \times 35 \text{ PPM})}{15 \text{ minutes}} = 35 \text{ PPM}$$
 - 10-minute exposure of 35 PPM
5-minute exposure of 15 PPM:
$$\frac{(10 \text{ minutes} \times 35 \text{ PPM}) + (5 \text{ minutes} \times 15 \text{ PPM})}{15 \text{ minutes}} = 28 \text{ PPM}$$

⚠ WARNING

If the STEL alarm condition is reached while using the instrument as a personal or area monitor, leave the contaminated area immediately; the ambient gas concentration has reached the preset STEL alarm level. Failure to follow this warning will cause over-exposure to toxic gases, which can result in serious personal injury or death.

Time Weighted Average (TWA) (FIGURE 3-13)



Figure 3-13. Exposure Page with TWA Alarm

- The TWA flag will appear in the upper portion of the display to show the average exposure since the instrument was turned ON or the TWA reading was reset.

- When the amount of gas detected by the Sirius Multigas Detector is greater than the eight-hour TWA limit:
 - Alarm Sounds
 - Alarm Lights Flash
 - TWA flashes.

To Reset the TWA:

1. Access the TWA page.
2. Press the RESET/▼ button.

The TWA alarm is calculated over an eight-hour exposure. Calculation examples are as follows:

- 1-hour exposure of 50 PPM:

$$\frac{(1 \text{ hour} \times 50 \text{ PPM}) + (7 \text{ hours} \times 0 \text{ PPM})}{8 \text{ hours}} = 6.25 \text{ PPM}$$

- 4-hour exposure of 50 PPM
4-hour exposure of 100 PPM:

$$\frac{(4 \text{ hours} \times 50 \text{ PPM}) + (4 \text{ hours} \times 100 \text{ PPM})}{8 \text{ hours}} = 75 \text{ PPM}$$

- 12-hour exposure of 100 PPM:

$$\frac{(12 \text{ hours} \times 100 \text{ PPM})}{8 \text{ hours}} = 150 \text{ PPM}$$

NOTE: The accumulated reading is always divided by eight hours.

⚠ WARNING

If the TWA alarm condition is reached while using the instrument as a personal or area monitor, leave the contaminated area immediately; the ambient gas concentration has reached the preset TWA alarm level. Failure to follow this warning will cause over-exposure to toxic gases, which can result in serious personal injury or death.

Time and Date Display (FIGURE 3-14)



Figure 3-14 Time Display

- The time appears on the display to show the current time of day in a 24-hour format.
- The **date** appears on the display with the current date displayed in the following format:
 - MM:DD:YY

PID Setup

⚠ WARNING

It is very important to have an understanding of PID basics when changing your PID settings. Failure to properly identify the VOC gas being measured, and failure to select the correct Response Factor alarm values (exposure, STEL, TWA) that match your desired Response Factor, and/or the correct bulb, will result in erroneous readings that could lead to serious injury or death.

Displaying Current Response Factor

To display and/or change your current VOC response factor, press PAGE/▲ until you see the Response Factor Page (FIGURE 3-15). This shows the eight-character identifier and multiplier for the current gas of interest. A complete list and reference table for the eight-character identifiers of all available gases is shown in TABLE 7-10.

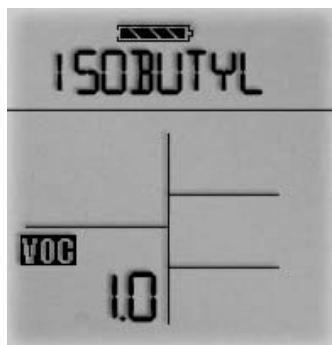

Figure 3-15. PID RF Page

Changing Response Factor

To change your current Response Factor, press RESET/▼ on the Response Factor Page.

- Up and down arrows appear on the display.
- User can now scroll, using the PAGE/▲ and RESET/▼ buttons.
- At any time, user can select the option display by pressing the ON-OFF/ACCEPT button.
- The first five Response Factors in the list are called favorites (these can be set using our MSA FiveStar Link program).
- The user has the option to turn OFF the PID (VOC detection), if desired.
- If the gas of interest isn't in the favorites list, select -MORE- to scroll through the entire list of pre-programmed Response Factors in alphabetical order.

Selecting a Custom Response Factor

If the gas of interest is not in the pre-programmed list, the user can use a Custom Response Factor if the multiplier is known for the gas compared to the Isobutylene calibration gas. To do this:

1. Go to the Response Factor page and press RESET/▼ button.
2. Scroll to and select -CUSTOM-.
3. Enter your desired eight-character identifier and multiplier.

4. Use the RESET/▼ button to scroll through the alphabet or numbers, and use the ON-OFF/ACCEPT button to select the letter and move on to the next letter.

Changing PID Bulb Selection

Several PID bulb options are available for this instrument. The two bulb options currently available are:

- 10.6 eV
- 9.8 eV

Changing to a different type bulb involves two steps:

- physically installing the bulb (see Chapter 6, **Removing and Cleaning the PID Bulb** for instructions on physically removing and installing the bulb)
- then updating the software to use the correct parameters for the new bulb.

To update the software:

1. Go to the Response Factor page; press the RESET/▼ button.
2. Scroll to and select -BULB- (FIGURE 3-14)



Figure 3-14. Changing PID Bulb Selection

3. Select the electron voltage of the desired bulb.
- If instrument is setup for use with a bulb other than the default 10.6 one, current bulb voltage will be displayed at turn ON.

⚠ WARNING

It is very important to have an understanding of PID basics when changing your PID settings. Failure to select the correct Response Factor alarm values (exposure, STEL, TWA) that match your desired Response Factor, and/or the correct bulb, will result in erroneous readings that could lead to serious injury or death.

Benzene Scrubber Procedure for Sirius PID (only if equipped with 9.8 eV lamp)

When used on the Sirius PID with a 9.8 eV lamp, the MSA Benzene scrubber tubes will:

- scrub most other background VOCs from benzene
- allow for a benzene specific reading with an average accuracy of 20% (0-100 ppm).

Conditions of use:

- temperature range of 5°C to 40°C (41°F to 104°F)
 - RH of up to 30g/m³ at 104°F .
1. turn unit ON.
 2. Mount the tube holder with quick-connect fitting on the Sirius instrument.
 3. After edging both tips of the benzene scrubber tube, break the scrubber tube tips with the tube breaker.
 4. Using the page button, go to the 'Benzene scrubber' page.
 5. Press RESET on the benzene scrubber page
 - Pump stops
 - Display shows 'start?' and '15' in the lower part of the display.
 6. Mount the scrubber tube on the quick-connect with tube holder according to the correct flow direction arrow on the tube.
 7. Press ON/OFF within 30 seconds to start the scrubbing process
 - Pump restarts and initiates the scrubber procedure by counting down from 15 to 0.

8. At the end of the countdown, a Benzene reading displays on the instrument VOC channel until:
 - a new benzene scrubber test is performed or
 - the instrument is turned OFF.
9. press RESET and ON/OFF to initiate the next scrubber reading.

NOTE: The Benzene scrubber page alternates between 'benzene' and 'scrubb' for 30 seconds; if no buttons are pressed for 30 seconds, the unit returns to the main measuring page.

Turning OFF the Sirius Multigas Detector

Push and Hold the ON-OFF/ACCEPT button for three seconds.

- Four audible beeps will be heard during the turn-off sequence.

NOTE: Releasing the ON-OFF/ACCEPT button before the three seconds elapse returns the instrument to the Measure page.

Chapter 4, Setting up the Sirius Multigas Detector

Power Systems

- The Sirius Multigas Detector is supplied with a rechargeable Lithium-Ion battery pack or a replaceable cell, four AA alkaline battery pack.

NOTE: For both types of battery packs, always remove the battery pack from the instrument if the instrument is not to be used for 30 days.

- See TABLE 4-1 for nominal run times by battery type. Note that there is a severe reduction in run time for instruments operated at colder temperatures.

Table 4-1.
Battery Type/Temperature/Approximate Run Time (Hours)

BATTERY TYPE	23°C (72°F)	0°C (32°F)	-20°C (-4°F)
Alkaline	6	4	1
Lithium-Ion	11	9	6

Battery Pack Removal and Replacement (FIGURE 4-1)

WARNING

Do not remove the instrument's battery pack in a hazardous area. Do not take battery packs into a hazardous area unless they are properly attached to the Sirius instrument!

To remove the battery pack from the Sirius Multigas Detector:

1. Unscrew the captive screw from the bottom of the battery door.

Table 4-2. Battery Type/Temperature Class

BATTERY	T4 UP TO 50°C	T3 UP TO 50°C
Rechargeable Li ION	●	●
Duracell	●	●
Varta		●
Energizer		●

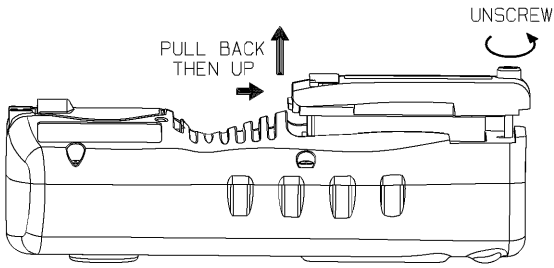

Figure 4-1. Battery Pack Removal

2. Pull the battery pack out of the instrument by gripping the sides of the battery pack door and lifting it up and away from the unit.
3. **For Alkaline battery packs:**
 - a. Pull the battery pack from the clip.

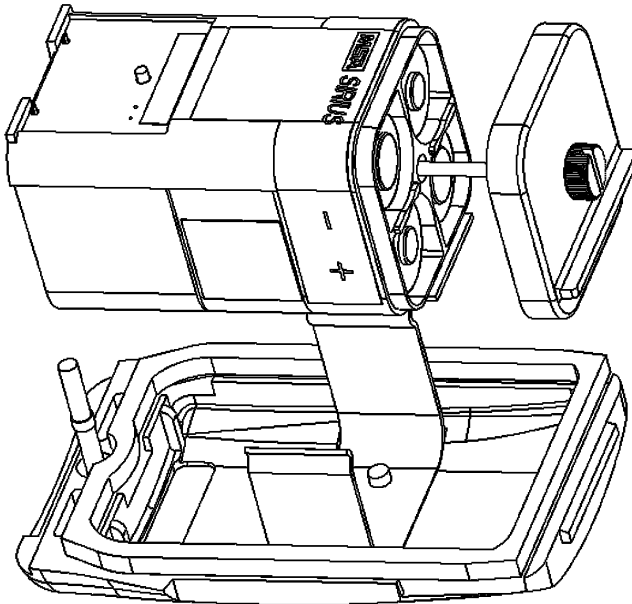

Figure 4-2. Changing Alkaline Batteries

- b. Unscrew the captive thumbscrew and lift the lid.
 - The lid will remain on the thumbscrew.
- c. Replace the batteries, using only batteries listed on the approval label, and replace the lid; tighten the thumbscrew.
- d. Slide the battery pack into the clip and reinstall the door.

Battery Charging (Lithium-Ion Battery Pack Only)

Charge the Sirius Multigas Detector Lithium-Ion battery pack by using the Sirius Charger supplied with the instrument. The Lithium-Ion battery pack can be charged while on or off the instrument.

CAUTION

Use of any charger, other than the Sirius Charger supplied with the instrument, may damage or improperly charge the batteries.

Do not charge in a hazardous area.

- The Sirius Multigas Detector must be turned OFF, or the battery pack may be removed from the instrument, prior to charging.

NOTE: If the instrument is not turned OFF, the charger connection will turn OFF the instrument without warning.

- The charger is capable of charging a completely depleted pack in less than six hours in normal, room-temperature environments.

NOTE: Allow very cold battery packs to stabilize for one hour at room temperature before attempting to charge.

- Minimum and maximum ambient temperature to charge the instrument: 10°C (50°F) to 35°C (95°F). Charging outside of this range may not be successful.
- For best results, charge the instrument at room temperature (23°C)

To Charge the Instrument

- Snap the charger onto the instrument.
- Do not restrict or block the ventilation openings on either side of the charger.
- Charge status is indicated by the LED on the charger.
 - **Red:** Charging in process

- **Green:** Charging complete
- **Yellow:** Failure Mode.
- If the red LED does not light and remain ON when the charger is attached, it is possible:
 - an incomplete electrical connection exists between the charger and the Lithium Ion battery pack contact points OR
 - the temperature of the battery pack is outside of the previously-indicated range.
- During recharge, the red LED turning OFF and and green LED not lighting is an indication of an improper charging process.
 - This is most likely caused by a battery pack temperature being outside of the previously-indicated range.

Restart the charging process with the battery pack in a different temperature environment.

- Failure mode, indicated by the yellow LED, will occur if either:
 - the battery pack has been deeply depleted beyond the point where it will accept a charge
 - an internal charger fault has been detected, which would result in an erroneous charging condition.
- Charger may be left on the instrument when charge is complete.

Changing Instrument Settings

- Many options can be set using the instrument buttons.
- If the Sirius Multigas Detector was ordered with the optional datalogging, the MSA FiveStar LINK software can be used to set most of the instrument selections, including some that cannot be changed from the instrument's front panel buttons.

Accessing the Instrument Setup Mode

- FIGURE 4-3 shows how to enter the Set-up mode.

SIRIUS FLOW DIAGRAM TO ENTER SETUP MODE

TO START SETUP MODE: SIRIUS UNIT MUST BE POWERED OFF

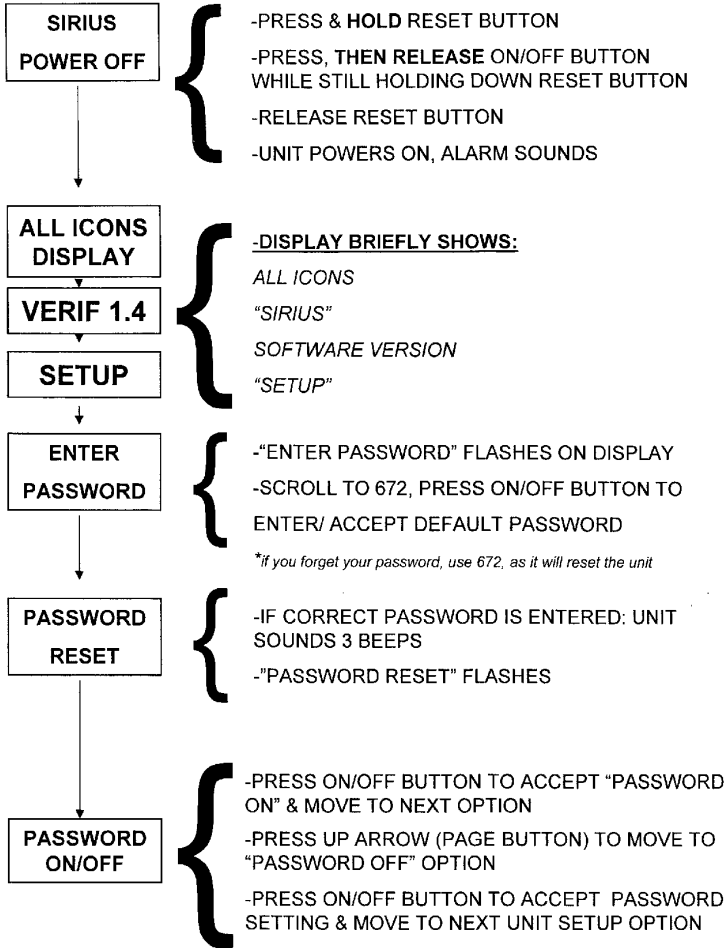

Figure 4-3.. Entering the Set-up Mode

1. Press and hold the RESET/▼ button while turning the instrument ON.
 - **SETUP** displays.

NOTE: In all of the following selections in this Set-up mode:

- Press ON/OFF to enter chosen value/go to the next page.
 - Press the ON/OFF button to store the chosen value.
 - Press RESET/▼ to decrement by one or toggle ON/OFF.
 - Press and hold RESET/▼ to decrement by 10.
 - Press PAGE/▲ to increment by one or toggle ON/OFF.
 - Press and hold PAGE/▲ to increment by 10.
2. Enter password default "672".
 3. Press ON/OFF to enter password.
 - Correct Password: instrument continues/beeps three times.
 - Incorrect Password: instrument enters the Measure mode.
 4. Password ON/OFF (turns the password protection ON or OFF)
 5. New Password Setup (changes the password)

Instrument Alarm Bypass Options

The Sirius Multigas Detector (with software version 1.1 or higher) is equipped with a feature to disable or silence the visual, backlight, and audible options. If any of these options are disabled during instrument startup, the Sirius Detector displays:

- "VISUAL OFF" if the red LEDs are disabled
- "AUDIBLE OFF" if the audible buzzer is disabled
- "BACKLITE OFF" if the backlight is disabled
- "BACKLIGHT TIME".

If the visual or audible options are disabled, "ALARM OFF" flashes on the LCD during Normal Measure mode.

6. Instrument Options Setup
 - Safe LED ON/OFF
 - Operating beep ON/OFF
 - STEL/TWA ON/OFF

- Cal Lockout Enable:
 - To disable calibration, turn this feature ON
 - When ON, calibration is only accessible via the Setup mode and password (if enabled)
- CAL Due Alert
 - To disable CAL Due messages, turn this feature OFF.
 - When ON, the number of days (1 to 180) between calibrations can be set. User will be required to acknowledge an overdue calibration at turn ON.
- Warm Up Info:
 - Turning this selection OFF causes the instrument NOT to display alarm setpoints at power-ON
- Time (if data logging option installed)
- Date (if data logging option installed)

7. LEL/CH₄ Setup

- Sensor ON/OFF (turns the sensor ON or OFF)
- Display Combustible Gas Type?
 - Methane
 - Pentane
 - Hydrogen
 - Propane
- LEL or CH₄ mode (displays % LEL (for any gas) or % CH₄ (for Methane only))
- Low Alarm (sets the low combustible alarm)
- High Alarm (sets the high combustible alarm)
- Cal Gas (sets the expected combustible calibration gas)

8. O₂ Setup

- Sensor ON/OFF (turns the sensor ON or OFF)
- Low Alarm
- High Alarm

9. CO Setup

- Sensor ON/OFF (turns the sensor ON or OFF)

- Low Alarm (sets the low CO alarm)
- High Alarm (sets the high CO alarm)
- STEL Alarm (if enabled) (sets the STEL CO alarm)
- TWA Alarm (if enabled) (sets the TWA CO alarm)
- Cal Gas (sets the expected CO calibration gas)

10.H₂S Setup

- Sensor ON/OFF (sets H₂S sensor ON or OFF)
- Low Alarm (sets the low H₂S alarm)
- High Alarm (sets the high H₂S alarm)
- STEL Alarm (if enabled) (sets the STEL H₂S alarm)
- TWA Alarm (if enabled) (sets the TWA H₂S alarm)
- Cal Gas (sets the expected H₂S calibration gas)

11.VOC Setup

- Sensor ON/OFF (sets VOC sensor ON or OFF)
- Low Alarm (sets the low VOC alarm)
- High Alarm (sets the high VOC alarm)
- STEL Alarm (if enabled) (sets the STEL VOC alarm)
- TWA Alarm (if enabled) (sets the TWA VOC alarm)
- VOC Auto-range (if enabled) (sets the display to read in 100 ppb increments when below 10 ppm)
 - Select ON for PPB
 - This mode allows for improved signal stability at low concentrations and can be used to determine if the low level VOC concentration is increasing or decreasing. Response times are longer (see TABLE 7-10, **PID Performance Specifications**).

WARNING

In VOC Auto-range, the response time will increase by approximately 10 seconds. Failure to wait the appropriate time can result in an incorrect reading.

- Display will read in increments of 100 ppb from 0 to 9900 ppb (9.9 ppm) (100 ppb = 0.1 ppm); then, it switches to ppm readings at readings ≥ 10 ppm.

NOTE: After set-up, the instrument will display:

"Warning - 100 ppb increments - see manual".

Press the ON/OFF button to acknowledge the warning and to continue.

WARNING

The VOC Auto-range displays readings in increments of 100 ppb from 0 to 9900 ppb. Do not rely on the value of the last two digits (00). Failure to correctly interpret the reading could result in VOC over-exposure.

- Display reading will flash between the reading and "ppb" for readings less than 9900 ppb (9.9 ppm).
- Select OFF for PPM
- Response Factor Page (turns the RF Page ON or OFF)
- Response Factor Save (if OFF, instrument always returns to Isobutylene at turn-ON)
- Response Factor Favorites:
 - Select the five favorite VOC gases for quick selection when changing response factors (See Chapter 3, **PID Setup**)
- Response Factor Change (see Chapter 3, **PID Setup**).

NOTE: Alarm values for PID have limits based on sensor performance. The Low alarm, STEL, and TWA cannot be set below 2.0 ppm and High alarm cannot be set below 10 ppm.

WARNING

It is very important to have an understanding of PID basics when changing your PID settings. Failure to properly identify the VOC gas being measured and/or failure to select the correct Response Factor alarm values (exposure, STEL, TWA) that match your desired Response Factor and/or the correct bulb, will result in erroneous readings that could lead to serious injury or death.

Chapter 5, Calibration

Calibrating the Sirius Multigas Detector

Each Sirius Multigas Detector is equipped with an Autocalibration feature to make unit calibration as easy as possible.

The Autocalibration sequence resets instrument zeroes and adjusts sensor calibration for known concentrations of calibration gases.

Table 5-1. Autocalibration and Required Calibration Cylinders

SENSORS	EXPECTED GAS* CONCENTRATION	FOUR-GAS CYLINDER (P/N 10045035)	ISOBUTYLENE (P/N 10028038)
Combustible	58% LEL	●	
Oxygen	15%	●	
Carbon Monoxide	60 ppm	●	
Hydrogen Sulfide	20 ppm	●	
VOC	100 ppm isobutylene		●
*Factory Default			

NOTE:

Refer to Chapter 4, **Setting up the Multigas Detector**, for instructions on changing the Autocalibration expected gas concentrations if calibration gas with concentrations other than those listed above will be used to calibrate the instrument.

⚠ WARNING

The expected gas concentrations must match the gas concentrations listed on the calibration cylinder(s). Failure to follow this warning will cause an incorrect calibration, which can result in serious personal injury or death.

To Calibrate the Sirius Multigas Detector (FIGURE 5-1):

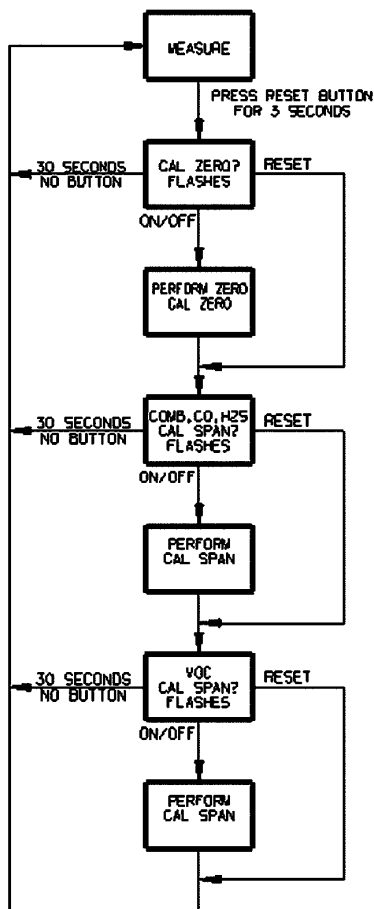

Figure 5-1. Calibration Flow Chart

1. Turn ON the instrument and verify that battery has sufficient life.
2. Wait until the Measure Gases page appears.
3. Push and hold the RESET/▼ button until **CAL ZERO?** flashes on the display (FIGURE 5-2).



Figure 5-2a. Zero Flag



Figure 5-2b. Zero Flag

4. Push the ON-OFF/ACCEPT button to zero the instrument.

- Instrument must be in fresh air to perform the zero.
- **CAL ZERO** flashes.

NOTE: To skip the Zero procedure and move directly to the calibration span procedure, push the RESET/▼ button. If no button is pushed for 30 seconds, the instrument returns to the Measure mode.

- Once the zeros are set, **CAL SPAN?** flashes (FIGURE 5-3).



Figure 5-3a. CAL Flag

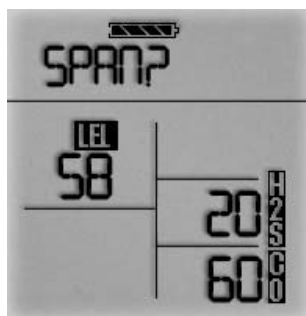

Figure 5-3b. CAL Flag

5. Connect the appropriate calibration gas to the instrument by connecting one end of the tubing to the pump inlet on the instrument and the other end of tubing to the cylinder regulator (supplied in the calibration kit).
6. Open the valve on the regulator, if so equipped.
7. Push the ON-OFF/ACCEPT button to calibrate (span) the instrument.
 - **CAL SPAN** flashes for approximately 90 seconds.
 - If autocalibration sequence passes, the instrument beeps three times and returns to the Measure mode.

NOTE: To skip calibration and return to the Measure mode, push the RESET/▼ button. If no button is pushed for 30 seconds, it will return to the Measure page.

8. Remove the tubing from the instrument.

9. Close the valve on the regulator, if so equipped.
10. Repeat steps 5 through 8 for the PID.

NOTE: The Autocalibration procedure adjusts the span value for any sensor that passes the test; sensors that fail autocalibration are left unchanged. Since residual gas may be present, the instrument may briefly go into an exposure alarm after the calibration sequence is completed.

Autocalibration Failure

If the Sirius Multigas Detector cannot calibrate one or more sensor(s), the instrument goes into the Autocalibration Failure Page and remains in alarm until the RESET button is pushed. Sensors that could not be calibrated are indicated by dashed lines on the concentration display.

- Check the calibration cylinder for:
 - accuracy
 - calibration setpoints
- Replace failed sensor or,
- if a VOC, clean the PID bulb and/or replace the ion chamber.

Chapter 6, Warranty, Maintenance, and Troubleshooting

MSA Portable Instrument Warranty

1. Warranty-

ITEM	WARRANTY PERIOD
Chassis and electronics	Two years
All sensors, unless otherwise specified	Two years
PID, including ion chamber	One year

This warranty does not cover fuses. Certain other accessories not specifically listed here may have different warranty periods. This warranty is valid only if the product is maintained and used in accordance with Seller's instructions and/or recommendations. The Seller shall be released from all obligations under this warranty in the event repairs or modifications are made by persons other than its own or authorized service personnel or if the warranty claim results from physical abuse or misuse of the product. No agent, employee or representative of the Seller has any authority to bind the Seller to any affirmation, representation or warranty concerning this product. Seller makes no warranty concerning components or accessories not manufactured by the Seller, but will pass on to the Purchaser all warranties of manufacturers of such components.

THIS WARRANTY IS IN LIEU OF ALL OTHER WARRANTIES, EXPRESSED, IMPLIED OR STATUTORY, AND IS STRICTLY LIMITED TO THE TERMS HEREOF. SELLER SPECIFICALLY DISCLAIMS ANY WARRANTY OF MERCHANTABILITY OR OF FITNESS FOR A PARTICULAR PURPOSE.

- 2. Exclusive Remedy-** It is expressly agreed that Purchaser's sole and exclusive remedy for breach of the above warranty, for any tortious conduct of Seller, or for any other cause of action, shall be the repair and/or replacement at Seller's option, of any equipment or parts thereof, which after examination by Seller is proven to be defective. Replacement equipment and/or parts will be provided at no cost to Purchaser, F.O.B. Seller's Plant. Failure of Seller to successfully repair any nonconforming product shall not cause the remedy established hereby to fail of its essential purpose.

3. **Exclusion of Consequential Damages-** Purchaser specifically understands and agrees that under no circumstances will seller be liable to purchaser for economic, special, incidental or consequential damages or losses of any kind whatsoever, including but not limited to, loss of anticipated profits and any other loss caused by reason of nonoperation of the goods. This exclusion is applicable to claims for breach of warranty, tortious conduct or any other cause of action against seller.

Cleaning and Periodic Checks

As with all electronic equipment, the Sirius Multigas Detector will operate only if it is properly maintained.

⚠ WARNING

Repair or alteration of the Sirius Multigas Detector, beyond the procedures described in this manual or by anyone other than a person authorized by MSA, could cause the instrument to fail to perform properly. Use only genuine MSA replacement parts when performing any maintenance procedures described in this manual. Substitution of components can seriously impair instrument performance, alter intrinsic safety characteristics or void agency approvals.

FAILURE TO FOLLOW THIS WARNING CAN RESULT IN SERIOUS PERSONAL INJURY OR DEATH.

Removing and Cleaning the PID Bulb

⚠ WARNING

Do not attempt to clean the PID bulb in a hazardous environment. The Sirius Multigas Detector must be turned OFF before cleaning or replacing the bulb and ion chamber. FAILURE TO FOLLOW THIS WARNING CAN RESULT IN SERIOUS PERSONAL INJURY OR DEATH.

Using a bulb that is contaminated with dust, dirt or oily residue can impair the performance of the instrument. Failure to clean the PID bulb can cause inaccurate readings, jeopardizing monitoring functions.

For the best performance, clean the PID bulb when:

- the monitor does not respond acceptably to a calibration check
- the PID Failed Span Cal occurs (to indicate low output)
- the PID Bulb/Cal Now error occurs

- the PID shows increased sensitivity to humidity
- the displayed PID reading is erratic.

If you are operating the monitor in a high temperature, high humidity, or dirty environment, you may need to clean the lamp more frequently to maintain optimal performance.

NOTES:

- Perform this procedure using methanol only.
- After cleaning, if the instrument still fails to calibrate, replace the bulb.
- All cleaning must be done in a clean, non-hazardous environment.

Cleaning Steps

1. Turn OFF the instrument.
2. While in a non-hazardous and non-combustible area, remove the battery pack.
3. Use a coin to gently unscrew the bulb access cap; set the cap on a clean surface.

NOTE: If the alternate tamper-resistant bulb access cap is installed, the special tool provided with the cap must be used.

4. Gently grasp the tapered end of the rubber bulb holder attached to the tip of the bulb and firmly pull the bulb holder straight out until the bulb comes free from the assembly.

⚠ CAUTION

Do not touch the bulb lens with your hands. The oily residue from your fingers will damage the window surface.

NOTE: Inspect the bulb window for scratches. Minor scratches should not affect bulb performance. If severe scratches and chips are present, replace the bulb.

⚠ CAUTION

Be careful not to allow dirt or particulates to fall into the bulb hole in the instrument.

5. Remove the rubber bulb holder from the end of the bulb and set the bulb holder on a clean surface.

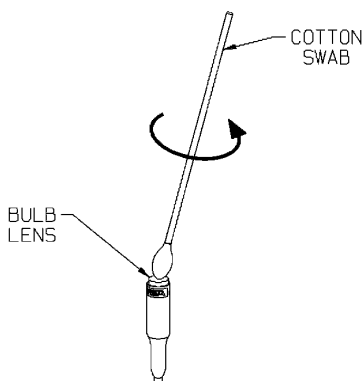

Figure 6-1. Cleaning the PID Bulb

6. Open the Bulb Cleaning Kit (P/N 10049691), consisting of cleaning implements and laboratory-grade methanol.
7. Moisten a clean cotton swab with methanol.
8. Hold the middle of the bulb body securely in your thumb and forefinger.
9. Using light pressure, rub the side of the swab in a circular motion over the surface of the window for 60 seconds.
10. Dispose of the swab.
11. Take a fresh swab and repeat steps 7 through 10.
12. Using a clean, dry swab, use light pressure and move the side of the swab over the window for 30 seconds.
13. Dispose of the swab.
14. Allow the bulb to dry for a minimum of 30 minutes before proceeding.

⚠ WARNING

Methanol can give a delayed, high response on the CO channel. When cleaning the bulb, it is important to ensure that all of the methanol cleaning compound has evaporated from the bulb before re-installation into the instrument.

15. Once the bulb is cleaned, inspect the bulb window for any dust or fibers.

NOTE: The bulb window and entire body of the bulb must be dust- and lint-free before re-assembly into the instrument.

16. Never touch the lens surface with your fingers. If contact occurs, repeat steps 6 through 13.
17. Gently insert the clean bulb, window first into the bulb sleeve of the instrument.

⚠ CAUTION

Do not apply excessive pressure when seating the bulb. Too much pressure may damage the detector and/or the bulb.

18. Push the open end of the rubber bulb holder onto the tip of the bulb. Gently push it on until it is fully seated.
19. Before replacing the bulb access cap, ensure the o-ring that goes around the bulb sleeve is in place. Replace the bulb access cap and tighten with a coin until it completely bottoms (no longer turns).
 - If using the tamper-resistant bulb access cap, the special tool provided with the cap must be used.

⚠ WARNING

Failure to tighten the bulb access cap fully may result in leakage in the flow system, causing inaccurate readings.

20. Turn ON the instrument and check the system for leaks by plugging the inlet with your finger.
 - The pump alarm should sound immediately. See Chapter 3, **Verifying Pump Operation**.
21. In a clean air environment, do a fresh air setup.
22. Allow the instrument to run for at least 15 minutes for the bulb to stabilize.
23. Recalibrate the instrument according to Chapter 5, **Calibration**.

NOTE: If a PID Failed Span Cal still occurs or an acceptable calibration cannot be performed, replace the PID bulb with a new one.

Replacing the Ion Chamber

Replace the ion chamber:

- when Changes in RH (wet to dry and dry to wet) cause erratic VOC readings with no analyte present
- if a PID Failed Span Cal still occurs after bulb replacement.

Use the Ion Chamber Replacement Kit (P/N 10050783).

▲ CAUTION

Remove and re-install the ion chamber in a clean, non-hazardous environment.

1. Turn OFF the instrument and, while in a non-hazardous and non-combustible area, remove the battery pack.
2. Unscrew the captive screw from the clear filter housing on the back of the instrument and remove the filter housing.
3. Gently remove the ion chamber cover assembly (FIGURE 6-2a) from the instrument and set the assembly on a clean, lint-free surface.
4. Using a small, flat-blade screwdriver, gently remove the ion chamber from the cell holder and discard (FIGURE 6-2b).

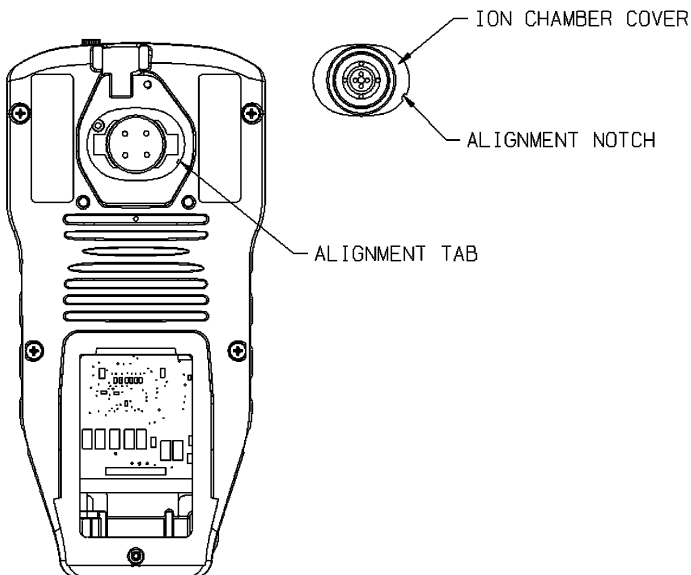

Figure 6-2a. Ion Chamber Removal

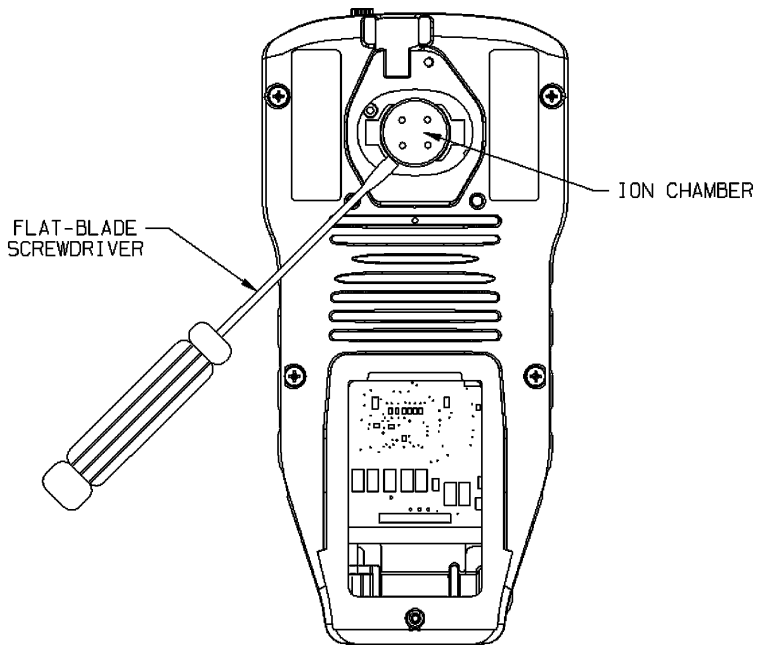

Figure 6-2b. Ion Chamber Removal

5. Using the 2.8-ounce container of 'canned air' found in the replacement kit, blow out any dust or dirt from the cell holder area (FIGURE 6-3a).

NOTE: Hold the cleaner in a vertical position; do not shake. Hold the instrument upright and with two to three short bursts, blow any debris from the cell holder area.

6. Remove the new ion chamber from its package.
7. Use the "canned air" to ensure ion chamber cleanliness.
 - a. Use the extension tube to blow through the inlet holes.
 - b. Blow off any debris from the underside.

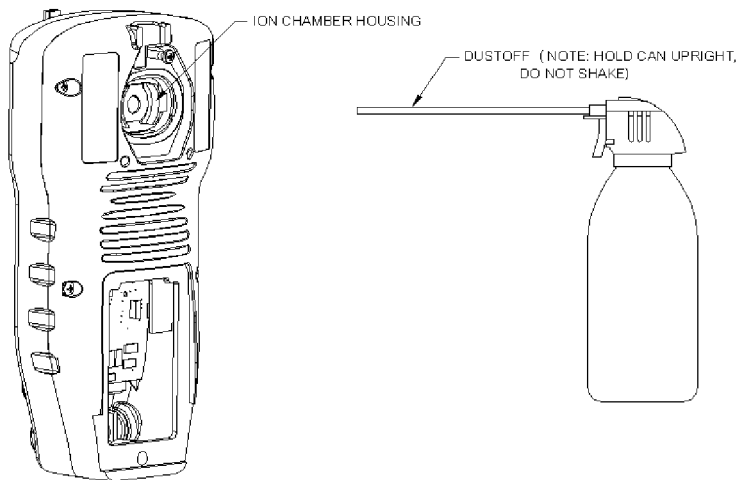

Figure 6-3a. Ion Chamber Housing Cleaning

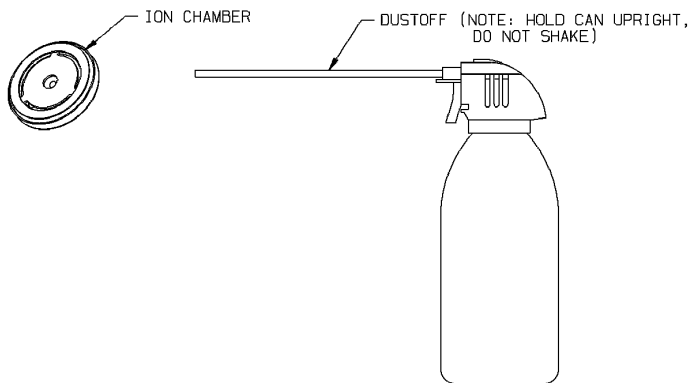

Figure 6-3b. Ion Chamber Cleaning

8. Snap the ion chamber into the cell holder, with the four small, round holes facing up as in FIGURE 6-4.
9. Replace the ion chamber cover, aligning the notch to ensure proper orientation.
10. Check that the o-rings are seated in their proper locations (see **Replacing the Filters**).

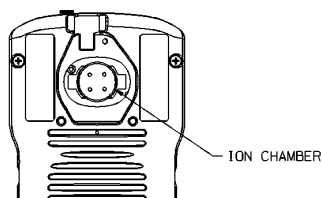

Figure 6-4. Ion Chamber Installation

11. Replace the filter housing and tighten the screw.
12. Place the used ion chamber in the reclosable package and discard.
13. Turn ON the instrument and check the system for leaks by plugging the inlet with a finger.
 - The pump alarm must sound. See Chapter 3, **Verifying Pump Operation**.

⚠ WARNING

Do not use the pump, sample line, or probe unless the pump alarm activates when the flow is blocked. Lack of an alarm is an indication that a sample may not be drawn to the sensors, which could cause inaccurate readings. Failure to follow the above can result in serious personal injury or death.

Replacing the Filters

⚠ CAUTION

When replacing external dust and water filters, prevent any dust or dirt around the filter housing from entering the PID sensor. Dust or dirt entering the PID sensor may impede or degrade PID sensor performance, especially in humid environments. Also, dust or dirt that gets pulled into the pump unit may impede pump operation.

DUST AND WATER FILTER

1. Turn OFF the instrument and, while in a non-hazardous and non-combustible area, remove the battery pack.
2. Unscrew the captive screw from the clear filter housing on the back of the instrument to access the filters.
3. Carefully lift out the O-ring, the water filter, and the fibrous dust filter from the recess on the filter housing.
4. Carefully install the new dust filter in the filter housing recess.

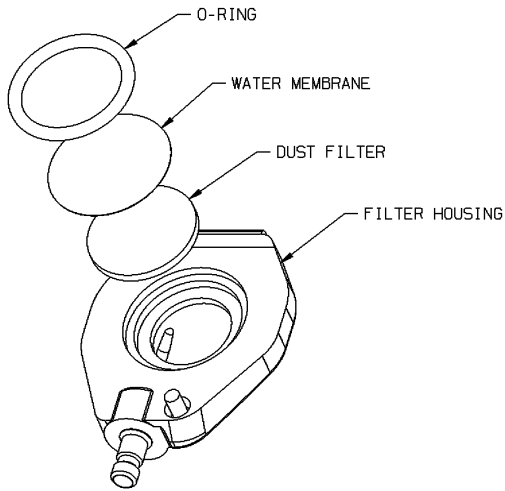

Figure 6-5. Filter Installation

5. Install the new water filter in the filter housing recess.
6. Replace the O-ring, being sure to press gently down on top of the water filter.

NOTE: When replacing the water filter, carefully handle the new filter by the edges only, as it is easily torn. Install the filters in the correct order.

- If the case oval-shaped O-ring comes out inadvertently when changing the filters, replace it in the oval-shaped groove in the back case before replacing the filter housing (FIGURE 6-6).

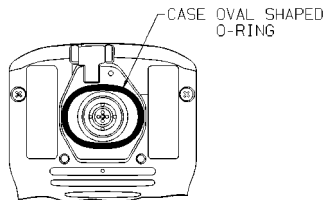

Figure 6-6. Case Oval-shaped O-ring

7. Re-install the filter housing and tighten the screw.
8. Check the system for leaks by plugging the inlet with a finger.
 - A pump alarm must sound. See Chapter 3, **Verifying Pump Operation**.

⚠ WARNING

Do not use the pump, sample line, or probe unless the pump alarm activates when the flow is blocked. Lack of an alarm is an indication that a sample may not be drawn to the sensors, which could cause inaccurate readings. Failure to follow the above can result in serious personal injury or death.

PROBE FILTER

- The MSA sampling probe contains a filter to:
 - block dust and dirt
 - block the passage of water.
- If the probe tip is accidentally submerged in water, the filter prevents the water from reaching the internal pump. The filter is not designed to stop other liquids, such as gasoline or alcohols.

To Replace the Probe Filter (FIGURE 6-7):

1. Grasp the probe handle by the base and guard.
2. Push the cap section toward the other two and turn clockwise.
 - The spring pushes the sections apart.
3. Grasp and spin the wand clockwise while pulling to disengage.

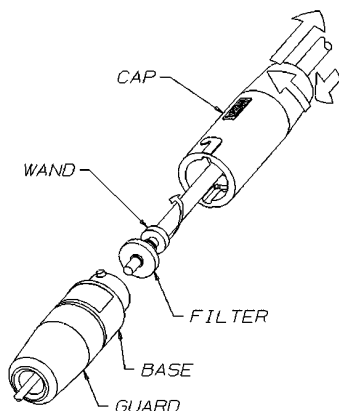

Figure 6-7. Replacing the Probe Filter

Storage

When not in use, store your Sirius Multigas Detector in a safe, dry place between 0° and 40°C (32° and 104°F).

⚠ WARNING

After storage, always recheck instrument calibration before use. During storage, sensors may drift or become inoperative and may not provide warnings of dangers to the health and lives of users.

Shipment

Pack the Sirius Multigas Detector in its original shipping container with suitable padding. If the original container is unavailable, an equivalent container may be substituted. Seal instrument in a plastic bag to protect it from moisture. Use sufficient padding to protect it from the rigors of handling. Damage due to improper packaging or damage in shipment is not covered by the instrument's warranty.

Troubleshooting

The Sirius Multigas Detector will operate reliably for years when cared for and maintained properly. If the instrument becomes inoperative, follow the Troubleshooting Guidelines in TABLE 6-1; these represent the most likely causes of a problem. You may return inoperative instruments to MSA for repair.

- **MSA Instrument Division
Repair and Service Department
1000 Cranberry Woods Drive
Cranberry Township, PA 16066-5207**

⚠ WARNING

Do not use the pump, sample line, or probe unless the pump alarm activates when the flow is blocked. Lack of an alarm is an indication that a sample may not be drawn to the sensors, which could cause inaccurate readings. Failure to follow the above can result in serious personal injury or death

To contact MSA International, please call:

- **1-412-967-3000 or 1-800-MSA-7777**

The instrument displays an error code if it detects a problem during startup or operation. See TABLE 6-1 for a brief description of the error and proper corrective action. When an inoperative component is located by using the guidelines, it may be replaced by using one of the following **Repair Procedures**.

Table 6-1. Troubleshooting Guidelines

PROBLEM	ACTION
Does not turn ON	Recharge (if applicable) or replace battery. See Chapter 4
Battery pack does not hold charge	Replace battery. See Chapter 4
Combustible sensor does not calibrate	Replace sensor. See Chapter 6
Oxygen sensor does not calibrate	Replace sensor. See Chapter 6
Toxic sensor does not calibrate	Replace sensor. See Chapter 6
Ion Error	Check that ion chamber is not installed upside down. Replace/dry chamber or clean with duster (P/N 10051715). See Chapter 6
PID Error	Check that ion chamber is installed. Clean or replace bulb if within normal temperature range. If temperature too cold, allow instrument to stabilize within normal temperature range before turning ON
Failed Span Cal Error (on PID)	Clean or replace bulb. See Chapter 6
PID Comm Error	Send instrument to authorized service center for repair
PID bulb/Cal now	Clean or replace bulb and recalibrate instrument. See Chapter 6
PID sensitivity to humidity	Clean or replace bulb/replace ion chamber. See Chapter 6
Noisy PID reading	Clean/replace bulb or ion chamber. See Chapter 6
CO sensor spurious signal at high temperature	Overexposure to Isobutylene or other interferent gases. Allow sensor to clear for 24 hours or replace CO sensor. See Chapter 7
Pump alarm	Check for leaks/blocks, replace dust and water filters. See Chapters 3 and 6
Sensor missing	Check installation of sensor/replace sensor. See Chapter 6
In all of the above cases and for any other problems, the Sirius Multigas Detector may be returned to MSA for repairs.	

Sensor Replacement

1. Verify the instrument is turned OFF.
2. Remove the battery pack.
3. Remove the four case mounting screws from the back of the case.
4. Remove the back case.

5. Gently lift out and properly discard the sensor to be replaced.
 - Use a flat-blade screwdriver to pry the CO and/or H₂S sensors from their holders.
6. For the combustible and/or O₂ sensor, carefully align the new sensor pins with the appropriate sockets on the (lower) printed circuit board. Press gently into position.
 - If a combustible and/or an O₂ sensor is not to be installed, ensure that the appropriate opening in the sensor gasket is sealed with a sensor cover label (tape disc) (P/N 710487).

NOTE: If a Long Term O₂ sensor is being installed, remove and discard circuit board connected to its pins before installation.

7. For the CO and/or H₂S sensors, carefully press them into their appropriate socket.
 - The CO sensor has a filter disc attached to it. Be careful not to damage the filter disk during handling and installation. Be sure the filter disk is facing upward when installed.
 - The H₂S sensor is marked "H₂S" on its top side; ensure that the "H₂S" mark and gas inlet hole face upward when installed.
 - If a CO and/or an H₂S sensor is not to be installed, ensure that an "inactive sensor plug" (P/N 10046292) is installed properly in its place.

NOTE: The CO and H₂S sensor positions must not be swapped. Verify that they are in the proper holder as indicated on the (upper) printed circuit board.

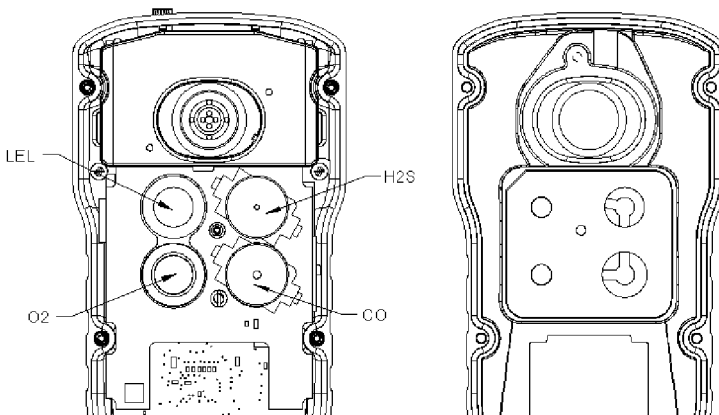

Figure 6-8. Sensor Locations

8. Re-install the back case.
9. Tighten the four captive case screws.
10. Re-install the battery pack.
11. Turn ON the instrument and allow the new sensor(s) to equilibrate with the environment temperature for approximately five minutes.
12. Check the system for leaks by plugging the inlet with a clean finger.
 - A pump alarm must sound. See Chapter 3, **Verifying Pump Operation**.

⚠ WARNING

Do not use the pump, sample line, or probe unless the pump alarm activates when the flow is blocked. Lack of an alarm is an indication that a sample may not be drawn to the sensors, which could cause inaccurate readings. Failure to follow the above can result in serious personal injury or death.

⚠ WARNING

Verification of calibration response is required; otherwise, the instrument will not perform as required, and the persons relying on this product for their safety could sustain serious personal injury or death.

Replacement of the Electronics Boards, the Display Assembly, the Horn Assembly, and the Pump

These parts must be replaced at an authorized factory service center.

Chapter 7, Performance Specifications

**Table 7-1. Certifications
(see instrument label to determine applicable approval)**

HAZARDOUS LOCATIONS	US (NON-MINING)	UL913 for Class I, Div. 1, Groups A, B, C and D, T3/T4*, Tamb=-20°C to +50°C
	CANADA	CSA C22.2, No. 157 for Class I, Div. 1, Groups A, B, C and D, T3/T4, Tamb=-20°C to +50°C
	EUROPE	EEx ia dIIC, T3/T4*, Tamb=-20°C to +50°C
PERFORMANCE	CANADA	CSA C22.2, No. 152 for Methane
	EUROPE	IEC60529
	EUROPE	*EN61779-1, EN61779-4 (Methane & Pentane)
	EUROPE	EN50271 (Software & Digital Technologies)
	EUROPE	EN50104 (Oxygen)
APPLICABLE EUROPEAN DIRECTIVES	ATEX 94/9/EC	II 2G EEx & d IIC, T3/T4*, Tamb=-20°C to +50°C
	EMC 89/336/EEC	EN50270 (EN50081-1, EN50082-2)
		* Li ION & Duracell: T4; Varta & Energizer: T3

Table 7-2. Instrument Specifications

TEMPERATURE RANGE	NORMAL	0 to 40°C
	EXTENDED	-20 TO 0°C, 40 to 50°C
INGRESS PROTECTION RATING (IP)		IP54
MEASUREMENT METHOD	COMBUSTIBLE GAS	Catalytic Sensor
	OXYGEN	Electrochemical Sensor
	TOXIC GASES	Electrochemical Sensors
	VOC	Photoionization Detector

FACTORY-SET ALARM SETPOINTS	LOW ALARM	HIGH ALARM	STEL	TWA
CO	35 PPM	100 PPM	400	35
H₂S	10 PPM	15 PPM	15	10
LEL	10%	20%	--	--
O₂	19.5%	23.0%	--	--
VOC	50	100	25	10

***NOTE:** Extended temperature range indicates gas readings may vary slightly if calibrated at room temperature. For optimal performance, calibrate instrument at temperature of use.

**Table 7-3.
COMBUSTIBLE GAS - Typical Performance Specifications**

REPRODUCIBILITY**

TEMPERATURE RANGE	GAS CONCENTRATION RANGE	REPRODUCIBILITY
-20°C up to 0°C (Extended)	0% up to and including 50% LEL	±5% LEL ²
	0.00% up to and including 2.50% CH ₄	±0.25% CH ₄ ²
	Above 50% and up to and including 100% LEL	±8% LEL ²
	Above 2.50% and up to and including 5.00% CH ₄	±0.40% CH ₄ ²
0°C to 40°C (Normal)	0% up to and including 50% LEL	±3% LEL ¹
	0.00% up to and including 2.50% CH ₄	±0.15% CH ₄ ¹
	Above 50% and up to and including 100% LEL	±5% LEL ¹
	Above 2.50% and up to and including 5.00% CH ₄	±0.25% CH ₄ ¹
Above 40°C and up to and including 50°C Extended	0% up to and including 50% LEL	±5% LEL ²
	0.00% up to and including 2.50% CH ₄	±0.25% CH ₄ ²
	Above 50% and up to and including 100% LEL	±8% LEL ²
	Above 2.50% and up to and including 5.00% CH ₄	±0.40% CH ₄ ²

Footnotes:

1. The Canadian Standards Association (CSA) has verified methane reproducibility in the normal temperature range per CSA Standard C22.2 No. 152.
2. CSA has verified methane reproducibility in the extended temperature ranges per the manufacturer's specifications. CSA has not verified methane reproducibility in the extended temperature ranges per CSA Standard C22.2 No. 152, because the extended temperature ranges are outside the scope of CSA Standard C22.2 No. 152.

Table 7-4.
COMBUSTIBLE GAS - Cross Reference Factors
for Sirius General-Purpose Calibration Using Calibration Cylinder
(P/N 10045035) Set to 58% LEL Pentane Simulant

COMBUSTIBLE GAS	MULTIPLY %LEL READING BY
Acetone	1.1
Acetylene	0.7
Acrylonitrile ¹	0.8
Benzene	1.1
Butane	1.0
1,3 Butadiene	0.9
n-Butanol	1.8
Carbon Disulfide ¹	2.2
Cyclohexane	1.1
2,2 Dimethylbutane	1.2
2,3 Dimethylpentane	1.2
Ethane	0.7
Ethyl Acetate	1.2
Ethyl Alcohol	0.8
Ethylene	0.7
Formaldehyde ²	0.5
Gasoline	1.3
Heptane	1.4
Hydrogen	0.6
n-Hexane	1.3
Isobutane	0.9
Isobutyl Acetate	1.5
Isopropyl Alcohol	1.1
Methane	0.6
Methanol	0.6
Methyl Isobutyl ketone	1.1
Methylcyclohexane	1.1
Methyl Ethyl Ketone	1.1
Methyl Tertiary Butyl Ether	1.0
Mineral Spirits	1.1
iso-Octane	1.1
n-Pentane	1.0
Propane	0.8
Propylene	0.8
Styrene ²	1.9

Tetrahydrofuran	0.9
Toluene	1.2
COMBUSTIBLE GAS	MULTIPLY % LEL READING BY
Vinyl Acetate	0.9
VM&P Naptha	1.6
O-Xylene	1.2

RESPONSE NOTES:

1. The compounds may reduce the sensitivity of the combustible gas sensor by poisoning or inhibiting the catalytic action.
2. These compounds may reduce the sensitivity of the combustible gas sensor by polymerizing on the catalytic surface.
3. For an instrument calibrated on Pentane, multiply the displayed %LEL value by the conversion factor above to get the true %LEL.
4. These conversion factors should be used only if the combustible gas is known.
5. These conversion factors are typical for a Sirius Multigas Detector. Individual units may vary by $\pm 25\%$ from these values

Table 7-5. OXYGEN - Typical Performance Specifications

RANGE	0 to 25% O ₂	
RESOLUTION	0.1% O ₂	
REPRODUCIBILITY**	0.7% O ₂ , for 0 to 25% O ₂	
RESPONSE TIME	90% of final reading	30 seconds with sample line and probe (normal temperature range*)
		3 minutes with sample line and probe (extended temperature range*)
	*See TABLE 7-2 NOTE	
	**See TABLE 7-10 NOTE	

Environment and Oxygen Sensor Readings

A number of environmental factors may affect the oxygen sensor readings, including changes in pressure, humidity and temperature. Pressure and humidity changes affect the amount of oxygen actually present in the atmosphere.

Pressure Changes

If pressure changes rapidly (e.g., stepping through airlock) the oxygen

sensor reading may temporarily shift, and possibly cause the detector to go into alarm. While the percentage of oxygen may remain at or near 20.8%, the total amount of oxygen present in the atmosphere available for respiration may become a hazard if the overall pressure is reduced to a significant degree.

Humidity Changes

If humidity changes to any significant degree (e.g., going from a dry, air conditioned environment to outdoor, moisture laden air), oxygen levels can change up to 0.5%. This is due to water vapor in the air displacing oxygen, thus reducing oxygen readings as humidity increases. The oxygen sensor has a special filter to reduce the affects of humidity changes on oxygen readings. This effect will not be noticed immediately, but slowly impacts oxygen readings over several hours.

Temperature Changes

The oxygen sensor has built-in temperature compensation. However, if temperature shifts dramatically, the oxygen sensor reading may shift. Zero the instrument at a temperature within 30°C of the temperature-of-use for the least effect.

Table 7-6.
CARBON MONOXIDE (appropriate models only) -
Typical Performance Specifications

RANGE	500 ppm CO
RESOLUTION	1 ppm CO, for 5 to 500 ppm CO
REPRODUCIBILITY**	±5 ppm CO or 10% of reading, whichever is greater 0 to 150 ppm CO, ±15% >150 ppm CO (normal temperature range*)
	±10 ppm CO or 20% of reading, whichever is greater (extended temperature range*)
RESPONSE TIME	90% of final reading in 50 seconds with sample line and probe (normal temperature range*)
	*See TABLE 7-2 NOTE
	**See TABLE 7-10 NOTE

Table 7-7. CARBON MONOXIDE - Cross Reference Factors for Sirius Calibration Using Calibration Cylinder (P/N 10045035)

NOTE: Data is presented as the indicated output in ppm, which would result from the application of 100 ppm of the test gas.

TEST GAS (100 PPM)	EQUIVALENT PPM
Carbon Monoxide (CO)	100 ±9
Hydrogen Sulfide (H ₂ S)	4 ±4
TEST GAS (100 PPM)	EQUIVALENT PPM
Sulfur Dioxide (SO ₂)	0 ±1
Nitrogen Dioxide (NO ₂)	2 ±6
Nitric Oxide (NO)	70 ±10
Chlorine (Cl ₂)	1 ±8
Ammonia (NH ₃)	2 ±4
Hydrogen Chloride (HCl)	3 ±2
Ethylene (C ₂ H ₄)	76 ±9
Hydrogen Cyanide (HCN)	0 ±1
Methane (CH ₄)	0 ±0
Ethanol (EtOH)	0
Hydrogen (H ₂)	70 +26

The carbon monoxide channel in the Sirius instrument is equipped with internal and external filters. The purpose of these filters is to protect the CO sensor from acid gases (H₂S, SO₂, etc.) and from the hydrocarbons that the instrument is intended to measure, including the calibration gas, isobutylene. In normal use, an interferent signal for calibration or bump checking the instrument should not be observed on the CO channel. However, exposure to large amounts of certain hydrocarbons (either long exposure times or high concentrations) can overwhelm the filter and appear as signals on the CO channel. In normal operation, after the hydrocarbon exposure is ended, the filter is designed to outgas absorbed hydrocarbons at a rate that will not cause a signal on the CO channel. However, if the unit is exposed to high temperature (≥40°C), this desorption rate increases and spurious signals may be observed on the CO channel due to gassing of previously absorbed hydrocarbons. If this occurs, it may be necessary to replace the CO sensor.

**Table 7-8. HYDROGEN SULFIDE (appropriate models only)
- Typical Performance Specifications**

RANGE	200 ppm H ₂ S
RESOLUTION	1 ppm H ₂ S, for 3 to 200 ppm H ₂ S
REPRODUCIBILITY**	±2 ppm H ₂ S or 10% of reading, whichever is greater 0 to 100 ppm H ₂ S, ±15% > 100 ppm H ₂ S (normal temperature range*)
	+5 ppm H ₂ S or 20% of reading, whichever is greater (extended temperature range*)
RESPONSE TIME	90% of final reading in 50 seconds* with sample line and probe (normal temperature range)
	*See TABLE 7-2 NOTE
	**See TABLE 7-10 NOTE

**Table 7-9. HYDROGEN SULFIDE - Cross Reference Factors
for Sirius Calibration Using Calibration Cylinder (P/N10045035)**

NOTE: Data is presented as the indicated output in ppm, which would result from the application of 100 ppm of the test gas

TEST GAS (100 PPM)	EQUIVALENT PPM
Hydrogen Sulfide (H ₂ S)	100 ±10
Ethylene (C ₂ H ₄)	0 ±0
Methane (CH ₄)	0 ±0
Hydrogen (H ₂)	0 ±0
TEST GAS (100 PPM)	EQUIVALENT PPM
Ammonia (NH ₃)	0 ±0
Chlorine (Cl ₂)	0 ±0
Nitrogen Dioxide (NO ₂)	-20 ±2
Nitric Oxide (NO)	1 ±1
Carbon Monoxide (CO)	4 ±4
Hydrogen Chloride (HCl)	0 ±0
Hydrogen Cyanide (HCN)	1 ±1
Sulfur Dioxide (SO ₂)	10 ±3
Ethanol (EtOH)	0 ±0
Toluene	0 ±0

**Table 7-10. PID (appropriate models only) -
Typical Performance Specifications**

RANGE	0 to 2000 ppm
DISPLAY	
RESOLUTION	0.1 ppm (100 ppb) from 0 to 2000 ppm; 1 ppm from 200 to 2000 ppm
REPRODUCIBILITY**	± 2 ppm (± 2000 ppb) or $\pm 10\%$, whichever is greater (normal temperature range*)
RESPONSE TIME	90% of final reading in 20 seconds (normal mode) 90% of final reading in 30 seconds (VOC ppb autorange)
* See TABLE 7-2	
** Assumes proper calibration and constant ambient conditions. Represents the range of possible variation between the displayed value and the actual concentration in a properly-calibrated instrument.	

Table 7-11. PID Response Factor Table

Analyte Name	CAS no. ¹	Chemical Formula	Sirius Displayed Name	IP, eV	Response Factors			Chemical Name
					9.8 eV lamp	10.6 eV lamp	11.7 eV lamp	
1,2,3-trimethylbenzene	526-73-8	C ₉ H ₁₂	123MEBNZ	8.42	0.53	0.58	Benzene, 1,2,3-trimethyl-	
1,2,4-trimethylbenzene	95-63-6	C ₉ H ₁₂	124MEBNZ	8.27	0.51	0.48	Benzene, 1,2,4-trimethyl-	
1,2-dibromomethane	106-93-4	C ₂ H ₂ Br ₂	12BRETHN	10.35	N/A ²	12.20	Ethane, 1,2-dibromo-	
1,2-dichlorobenzene	95-50-1	C ₆ H ₄ Cl ₂	12CLBNZ	9.06	0.57	0.43	Benzene, 1,2-dichloro-	
1,3,5-trimethylbenzene	108-67-8	C ₉ H ₁₂	135MEBNZ	8.40	0.43	0.37	Benzene, 1,3,5-trimethyl-	
1,4-butanediol	110-63-4	C ₄ H ₁₀ O ₂	BUTNDIOL	10.70	N/A	N/A	1,4-Butanediol	
1,4-dioxane	123-91-1	C ₄ H ₈ O ₂	DIOXANE	9.19	1.35	1.06	1,4-Dioxane	
1-butanol	71-36-3	C ₄ H ₁₀ O	BUTANOL	9.99	N/A	2.30	1-Butanol	
1-methoxy-2-propanol	107-98-2	C ₄ H ₁₀ O ₂	MEOXPROP	9.54	1.89	0.89	Propan-2-ol, 1-methoxy-	
1-propanol	71-23-8	C ₃ H ₈ O	PROPANOL	10.22	N/A	4.74	1-Propanol	
2-butanone	78-93-3	C ₄ H ₈ O	BUTANONE	9.52	0.76	0.70	2-Butanone	
2-methoxyethanol	109-86-4	C ₃ H ₈ O ₂	MEOXETHO	10.13	N/A	1.45	Ethanol, 2-methoxy-	
2-pentanone	107-87-9	C ₅ H ₁₀ O	2PENTANO	9.38	0.80	0.68	2-Pentanone	
2-picoline	109-06-8	C ₈ H ₉ N	2PICOLIN	9.40	0.59	0.41	Pyridine, 2-methyl-	
2-propanol	67-63-0	C ₃ H ₈ O	IPROPNOL	10.17	N/A	2.72	Isopropyl alcohol	
3-picoline	108-99-6	C ₈ H ₉ N	3PICOLIN	9.00	0.42	0.45	Pyridine, 3-methyl-	
4-hydroxy-4-methyl-2-pentanone	123-42-2	C ₆ H ₁₂ O ₂	PYRATON	9.50	0.42	0.36	4-Hydroxy-4-methylpentan-2-one	
acetaldehyde	75-07-0	C ₂ H ₄ O	ETHANAL	10.23	N/A	4.57	Acetaldehyde	
acetone	67-64-1	C ₃ H ₆ O	ACETONE	9.70	0.96	1.12	Acetone	
acetophenone	98-86-2	C ₈ H ₈ O	ETANONE	9.28	1.36	0.78	Acetophenone	
acrolein	107-02-8	C ₃ H ₄ O	ACROLEIN	10.11	N/A	3.82	2-Propenal	
acrylic acid	79-10-7	C ₃ H ₄ O ₂	ACRLCADC	10.60	N/A	7.63	2-Propenoic acid	
allyl alcohol	107-18-6	C ₃ H ₆ O	PROPENOL	9.67	6.04	1.81	2-Propen-1-ol	
ammonia	7664-41-7	NH ₃	AMMONIA	10.07	N/A	2.51	Ammonia	
amyl acetate	628-63-7	C ₇ H ₁₄ O ₂	AMYLACET	?	5.32	1.65	Acetic acid, pentyl ester	
arsine	7784-42-1	AsH ₃	ARSINE	10.18	N/A	2.71	Arsenic trihydride	
benzene	71-43-2	C ₆ H ₆	BENZENE	9.24	0.56	0.53	Benzene	
bromomethane	74-83-9	CH ₃ Br	BRMETHAN	10.54	N/A	1.40	Methyl bromide	
butadiene	106-99-0	C ₄ H ₆	BUTADIEN	9.07	0.65	0.63	1,3-Butadiene	
butoxyethanol	111-76-2	C ₈ H ₁₈ O ₂	BTOXETHO	8.68	1.46	0.80	2-n-Butoxy-1-ethanol	

Table 7-11. PID Response Factor Table (continued)

Analyte Name	CAS no. ¹	Chemical Formula	Sirius Displayed Name	IP, eV	Response Factors			Chemical Name
					9.8 eV lamp	10.6 eV lamp	11.7 eV lamp	
butyl acetate	123-86-4	C ₆ H ₁₂ O ₂	BTYLACET	10.00	N/A	2.22	Acetic acid, butyl ester	
carbon tetrachloride	56-23-5	CCl ₄	CARBONT	11.47	N/A	N/A	Carbon tetrachloride	
chlorine	7782-50-5	Cl ₂	CHLORINE	11.51	N/A	N/A	Chlorine	
chlorobenzene	108-90-7	C ₆ H ₅ Cl	CLBNZE	9.07	0.34	0.36	Benzene, chloro-	
cumene	98-82-8	C ₉ H ₁₂	CUMENE	8.73	0.54	0.54	Benzene, (1-methylethyl)-	
cyclohexane	110-82-7	C ₆ H ₁₂	CYCHEXAN	9.88	2.88	1.17	Cyclohexane	
cyclohexanone	108-94-1	C ₆ H ₁₀ O	CYCHEXON	9.16	0.26	0.27	Cyclohexanone	
decane	124-18-5	C ₁₀ H ₂₂	DECANE	9.65	2.67	0.87	Decane	
dichloroethane	107-06-2	C ₂ H ₄ Cl ₂	DICLETHAN	11.07	N/A	N/A	Ethane, 1,2-dichloro-	
Diesel #2	68476-34-6	mixture	DIESEL2		1.46	0.80		
Diesel #4, Marine Diesel	77650-28-3	mixture	DIESEL4		1.46	0.80		
Diesel Oil, Diesel Fuel	68334-30-5	mixture	DIESEL		1.46	0.80		
diethylamine	109-89-7	C ₄ H ₁₁ N	DIETAMNE	8.01	0.30	0.31	Ethanamine, N-ethyl-	
dimethoxymethane	109-87-5	C ₃ H ₈ O ₂	DIMEOXME	10.00	N/A	1.63	Methane, dimethoxy-	
dimethylacetamide	127-19-5	C ₄ H ₉ NO	DMA	8.81	0.63	0.47	Acetamide, N,N-dimethyl-	
dimethylformamide	68-12-2	C ₃ H ₇ NO	DMF	9.13	0.60	0.46	Formamide, N,N-dimethyl-	
epichlorohydrin	106-89-8	C ₃ H ₅ ClO	ECL2HYDN	10.64	N/A	N/A	Oxirane, (chloromethyl)-	
ethanol	64-17-5	C ₂ H ₆ O	ETHANOL	10.48	N/A	9.25	Ethanol	
ethyl acetate	141-78-6	C ₄ H ₈ O ₂	ETACET	10.01	N/A	2.85	Ethyl acetate	
ethyl acetoacetate	141-97-9	C ₈ H ₁₆ O ₃	EEA	?	1.02	0.66	Butanoic acid, 3-oxo-, ethyl ester	
ethylbenzene	100-41-4	C ₈ H ₁₀	ETBNZE	8.77	0.46	0.43	Ethylbenzene	
ethylene	74-85-1	C ₂ H ₄	ETHYLENE	10.51	N/A	6.30	Ethylene	
ethylene glycol	107-21-1	C ₂ H ₆ O ₂	ETGLYCOL	10.50	N/A	N/A	1,2-Ethanediol	
ethylene oxide	75-21-8	C ₂ H ₄ O	ETOXIDE	10.56	N/A	34.3	Ethylene oxide	
Fuel Oil #2	68476-30-2	mixture	FUELOIL2		1.46	0.80		
γ-butyrolactone	96-48-0	C ₄ H ₆ O ₂	GBUTRLCN	10.26	N/A	3.78	γ-Butyrolactone	
gasoline (unleaded)	8006-61-9	mixture	GASOLINE		2.27	2.01		
heptane	142-92-5	C ₇ H ₁₆	HEPTANE	9.93	N/A	2.01	Heptane	
hexane	110-54-3	C ₆ H ₁₄	HEXANE	10.13	N/A	2.88	Hexane	
hydrazine	302-01-2	H ₄ N ₂	HYDRAZINE	8.10	7.78	3.23	Hydrazine	

Table 7-11. PID Response Factor Table (continued)

Analyte Name	CAS no. 1	Chemical Formula	Sirius Displayed Name	IP, eV	Response Factors			Chemical Name
					9.8 eV lamp	10.6 eV lamp	11.7 eV lamp	
isoamyl acetate	123-92-2	C ₇ H ₁₄ O ₂	IAMYACET	9.90	N/A	1.65	1-Butanol, 3-methyl-, acetate	
isobutanol	78-83-1	C ₄ H ₁₀ O	IBUTANOL	10.22	N/A	5.24	1-P-Propanol, 2-methyl-	
isobutylene	115-11-7	C ₄ H ₈	ISOBUTYL	9.02	1.00	1.00	1-P-Propene, 2-methyl-	
isooctane	540-84-1	C ₈ H ₁₈	IOCTANE	9.89	2.75	0.91	Pentane, 2,2,4-trimethyl-	
isophorone	78-59-1	C ₉ H ₁₈ O	IPHORNE	9.07	0.21	0.20	2-Cyclohexen-1-one, 3,5,5-trimethyl-	
isopropylamine	75-31-0	C ₃ H ₉ N	2PROPAME	8.60	0.61	0.51	2-P-Propanamine	
isopropyl ether	108-20-3	C ₆ H ₁₄ O	IPROETHR	9.20	0.72	0.62	Diisopropyl ether	
Jet A(A1)	8008-20-6	mixture	JETA(A1)		1.04	0.36		
JP 4, jet B	8008-20-6	mixture	JP4		1.57	1.03		
JP 5	8008-20-6	mixture	JP5		1.04	0.36		
JP 8	8008-20-6	mixture	JP8		1.04	0.36		
methyl oxide	141-79-7	C ₂ H ₄ O	MSTYLOXD	9.10	0.48	0.40	3-P-Penten-2-one, 4-methyl-	
m-xylene	108-38-3	C ₈ H ₁₀	MXYLENE	8.55	0.80	0.80	Benzene, 1,3-dimethyl-	
methanol	67-56-1	CH ₄ O	MEOH	10.84	N/A	N/A	Methyl alcohol	
methyl acetate	79-20-9	C ₄ H ₈ O ₂	MEACET	10.25	N/A	5.47	Acetic acid, methyl ester	
methyl acetoacetate	105-45-3	C ₆ H ₈ O ₃	MEACACET	9.82	1.23	0.87	Butanoic acid, 3-oxo-, methyl ester	
methyl acrylate	96-33-3	C ₅ H ₈ O ₂	MEACRYLT	10.70	N/A	3.09	2-P-Propenoic acid, methyl ester	
methyl benzoate	93-59-3	C ₈ H ₈ O ₂	MEBNZOTE	9.32	6.50	1.88	Benzoic acid, methyl ester	
methylbenzyl alcohol	589-18-4	C ₉ H ₁₀ O	MEBNZOL	?	1.49	0.81	Benzenemethanol, 4-methyl-	
methyl ethyl ketone	78-93-3	C ₆ H ₁₀ O	MEK	9.52	0.76	0.65	2-Butanone	
methyl isobutyl ketone	108-10-1	C ₈ H ₁₆ O	MIBK	9.30	0.76	0.65	Methyl isobutyl ketone	
methyl methacrylate	80-62-6	C ₅ H ₈ O ₂	MEMEACRY	10.06	N/A	0.94	2-P-Propenoic acid, 2-methyl-, methyl ester	
methyl tert-butylether	1634-04-4	C ₈ H ₁₈ O	MTBE	9.41	0.84	0.74	Propane, 2-methoxy-2-methyl-	
methylene chloride	75-09-2	CH ₂ Cl ₂	METYLCL2	11.33	N/A	N/A	Methylene chloride	
monomethylamine	74-89-5	CH ₅ N	MEAMINE	8.90	0.85	0.76	Methylamine	
n-methylpyrrolidone	872-50-4	C ₅ H ₉ NO	MEPRYLDN	9.17	1.22	0.58	2-Pyrrolidinone, 1-methyl-	
octane	111-65-9	C ₈ H ₁₈	OCTANE	9.80	11.7	1.61	Octane	
o-xylene	95-47-6	C ₈ H ₁₀	OXYLENE	8.56	0.51	0.46	Benzene, 1,2-dimethyl-	
p-xylene	106-42-3	C ₈ H ₁₀	PXYLENE	8.44	0.41	0.50	Benzene, 1,4-dimethyl-	
phenol	108-95-2	C ₆ H ₆ O	PHENOL	8.49	N/A	N/A	Phenol	

Table 7-11. PID Response Factor Table (continued)

Analyte Name	CAS no. ¹	Chemical Formula	Sirius Displayed Name	IP, eV	Response Factors			Chemical Name
					9.8 eV lamp	10.6 eV lamp	11.7 eV lamp	
phenylethyl alcohol	60-12-8	C ₈ H ₁₀ O	BNZETOH	10.00	N/A	N/A	Benzeneethanol	
phosphine	7803-51-2	PH ₃	PHOSPHIN	9.87	N/A	2.64	Phosphine	
propylene	115-07-1	C ₃ H ₆	PROPENE	9.73	1.25	1.06	Propene	
propylene oxide	75-56-9	C ₃ H ₆ O	PROPLYOX	10.22	N/A	4.84	Propylene oxide	
pyridine	110-86-1	C ₅ H ₅ N	PYRIDINE	9.26	0.60	0.53	Pyridine	
quinoline	91-22-5	C ₉ H ₇ N	QUINOLINE	8.63	14.2	0.47	Quinoline	
styrene	100-42-5	C ₈ H ₈	STYRENE	8.46	0.40	0.32	Styrene	
tert-butyl alcohol	75-65-0	C ₄ H ₁₀ O	TBUOH	9.90	23.7	2.27	Ethanol, 1,1-dimethyl-	
tert-butylamine	75-64-9	C ₄ H ₁₁ N	TBUAMINE	8.50	0.42	0.41	2-Propanamine, 2-methyl-	
tert-butylmercaptan	75-66-1	C ₄ H ₁₀ S	TBUMRCAP	9.03	0.45	0.36	2-Propanethiol, 2-methyl-	
tetrachloroethylene	127-18-4	C ₂ Cl ₄	(CL)4ET	9.33	0.64	0.49	Tetrachloroethylene	
tetrahydrofuran	109-99-9	C ₄ H ₈ O	THF	9.40	1.66	1.47	Furan, tetrahydro-	
thiophene	110-02-1	C ₄ H ₄ S	THIOLE	8.86	0.41	0.52	Thiophene	
toluene	108-88-3	C ₇ H ₈	TOLUENE	8.83	0.62	0.56	Toluene	
trans-dichloroethene	156-60-5	C ₂ H ₂ Cl ₂	CL2ETHN	9.64	0.42	0.37	Ethene, 1,2-dichloro-, (E)-	
trichloroethylene	79-01-6	C ₂ HCl ₃	(CL)3ETL	9.46	0.44	0.36	Trichloroethylene	
turpentine - pure gum spirits	8006-64-2	mixture	TURPS		0.12	0.17		
vinyl acetate	108-05-4	C ₄ H ₆ O ₂	VNYLACET	9.20	1.36	0.94	Acetic acid ethenyl ester	
vinyl chloride	75-01-4	C ₂ H ₃ Cl	VNL.YCLDE	9.99	N/A	1.47	Ethene, chloro-	
vinylcyclohexane	695-12-5	C ₈ H ₁₄	VYLCYHEX	9.51	0.73	1.38	Cyclohexane, ethenyl-	

¹ CAS no. or Chemical Abstracts Service No. - An internationally recognized unique identifier of chemical compounds. The CAS no. is listed on Material Safety Data Sheets (MSDS).

² N/A - Not applicable: This lamp cannot be used to detect this analyte because the ionization energy of the compound is greater than the energy of the lamp or the kinetics of the ionization process or follow-on reactions of the ions prevent detection.

⚠ WARNING

VOC Response factors apply in the 0-500 ppm range. The values in this table were obtained using dry bottled gases at 25°C. The response factors may change at higher concentrations, different temperature and humidity conditions, or with cleanliness of lamp. For increased accuracy at different ambient conditions or concentrations, determine a custom response factor and enter it via the Response Factor page; see Chapter 3, **Selecting a Custom Response Factor**. These response factors are specific to the energy of the lamp designated in the table. They are not valid for instruments using PID bulbs at any other energy. Using these response factors with a lamp at any other energy may critically compromise the instrument's ability to detect organic compounds which can result in serious personal injury or death.

⚠ WARNING

Use of Sirius PID for detection of extremely toxic gases:
The system resolution limit of the Sirius PID in normal mode (with a new, clean lamp) is approximately 0.1 ppm isobutylene equivalent. Users must be aware of exposure limit guidelines, such as TLV, for the target analyte. Do not use the Sirius PID Detector if the exposure limit for the target analyte is below 0.1 ppm. Failure to follow this warning can cause over-exposure, which can result in serious personal injury or death.

For any analyte, its exposure limit guideline can be recalculated in terms of equivalent ppm isobutylene by dividing the exposure limit guideline by the appropriate response factor.

Example: For butadiene (CAS 106-99-0), the recommended threshold limit value (as TWA) is 1 ppm. Its response factor (10.6 eV lamp) is 0.69. The TLV for butadiene, in terms of equivalent ppm isobutylene is:

$$\text{ppm} \div 0.69 = 1.4 \text{ ppm isobutylene equivalent.}$$

⚠ WARNING

The Sirius PID Detector has a reproducibility of ± 2 ppm (± 2000 ppb) or 10%, whichever is greater (see TABLE 7-10). The user must account for this potential variation between the displayed value and the actual concentration when setting alarms and interpreting readings. Failure to comply with this warning can cause over-exposure and result in serious personal injury or death.

Gases with very high response Factors (RF):

The Sirius PID is a very versatile solution for monitoring many different gases and vapors. In addition to the pre-programmed list provided in the Sirius instrument, users can determine response factors for many other compounds (see Section 7). The maximum response factor value that will be accepted by the Sirius instrument is 39.99. Following the procedure in Section 7, if a response factor of greater than 39.99 is experimentally determined, the user must use the next higher energy lamp (9.6, 10.6, or 11.7 eV) to monitor that compound. If a response factor of greater than 39.99 is experimentally determined when using the 11.7 eV lamp, the compound of interest has an ionization potential too high to be detected reliably using the Sirius instrument.

▲ WARNING

Use the correct bulb when determining the response factor. Failure to apply the appropriate response factors can result in inaccurate readings, and serious injury or death can occur.

Contact MSA Customer Service at 1-800-MSA-2222 with any question regarding the above information.

These additional response factors were determined by MSA Chemists using the Sirius Multigas Detector. The listing consists of response factors for several common industrial chemicals that are not preprogrammed into the instrument. Using your IBM compatible PC with the Data Logging Software and Data Docking Module, you can add a response factor from this list to the monitor's internal gas table. Consult the Data Logging Software User's Manual for specific instruction.

MSA is continually developing new Response Factors; contact MSA if your compound of interest is not listed.

Table 7-12. Known Interference Data for listed VOCs

CHEMICAL	CONCENTRATION	SENSOR CHANNEL			
		LEL	O2	H2S	CO
ethylene oxide	2297 ppm				43 (5)
arsine	186 ppm			176 (5)	
phosphine	303 ppm			172 (5)	
propylene	151.6 ppm				19 (5)
ethylene	101 ppm				76 (5)
methanol	994 ppm				*

⚠ WARNING

***Methanol can give a delayed, high response on the CO channel. When cleaning the bulb, it is important to ensure that all of the methanol cleaning compound has evaporated from the bulb before re-installation into the instrument.**

Chapter 8, Replacement and Accessory Parts

Table 8-1. Accessory Parts List

PART	PART NO.
Probe - 1 ft.	10042621
Probe - 3 ft.	10042622
Sampling Line - 10 ft.	10040665
Sampling Line - 25 ft.	10040664
Sampling Line - 10 ft. Teflon, straight	10049058
Sampling Line - 25 ft. Teflon	10049057
Replacement Filter, Probe (pkg. of 10)	801582
Protective Jacket, Orange Nylon	10050122
Protective Rubber Boot, Black	10050123
Protective Rubber Boot, Red (North American-approved instrument only)	10050124
Calibration Kit Model RP with 0.25 lpm Regulator	10050984
Calibration Gas - 58% LEL pentane simulant / 15% O ₂	478192
Calibration Gas - 58% LEL pentane simulant / 15% O ₂ ; 20 ppm H ₂ S	10048788
Calibration Gas - 58% LEL pentane simulant / 15% O ₂ ; 60 ppm CO and 20 ppm H ₂ S	10045035
Calibration Gas, 100 ppm Isobutylene	494450
Zero Gas Air	801050
Bump Test Kit	10050857
Squirt Gas, 52% LEL Pentane/15% O ₂ /60 ppm CO	814497
Squirt Gas, 52% LEL Pentane/15% O ₂	815308
Squirt Gas, 52% LEL Pentane/15% O ₂ / 300 ppm CO/35 ppm H ₂ S	814559
Squirt Gas, Isobutylene	815704
Gas Miser Regulator, Model RP	710288
Regulator, .25 LPM, Model RP	478359
Regulator, Combination, .25 LPM, Model RP	711175
Calibration Kit, Multiflow Demand	10050985
Calibration Kit, Combination, .25 LPM	10050986
Battery Charger Assembly (less power adapter)	10050223
Battery Charger, Power Adapter, A.C., North America	10047342
Battery Charger, Power Adapter, Vehicle	10049410
Battery Charger Power Adapter, AC, Global	10047343
Battery Pack, Li-Ion, UL/CSA Version	10050347
Battery Pack, Li-Ion, ATEX Version	10052296
Protective Plug, Li-Ion Pack	10051681
Aerosol Duster	10051715

Zero Air Filter Cartridge	10054078
FiveStar Link and Jeteye	710946
FiveStar Link Software	710988
Battery Pack, Alkaline (less door), UL/CSA version	10049098
Oxygen Sensor, Long Term storage	10049807
Tamper-resistant Cap Removal Tool	10051979
Battery Pack, Alkaline (less door), ATEX version	10064569
Charger with Power Supply, ATEX version	10068655
Charger Stand, ATEX version	10066628
Global Power Supply	10065716

Table 8-2. Replacement Parts List

PART	PART NO.
Screw Replacement Kit	10051537
Oxygen Sensor	10049806
Hydrogen Sulfide Sensor	10049805
Combustible Sensor	10049808
Carbon Monoxide Sensor	10049804
Case Gasket	10049894
Water Membrane, package of five	10051250
Dust filter, package of five	808935
Inlet Filter Assembly	10050843
Case Rear Assembly with Sensor Gasket	10051978
Filter Cover O-ring	10049892
Ion Chamber	10049768
PID Bulb 9.8 eV	10052298
PID Bulb 10.6 eV	10049692
PID Bulb Cleaning Kit	10049691
Lamp Access Cap	10050841
Lamp Access Cap, Tamper Resistant	10050750
Lamp Access Cap O-Ring	10050855
Battery Door Assembly, Alkaline, North American	10049411
Battery Door Assembly, ATEX Version	10051981
Rubber Bulb Holder	10050842
Alkaline "Module" Door and Pack UL/CSA Version	10049412
Alkaline "Module" Door and Pack ATEX Version	10051980
Inactive Sensor Plug	10046292
Sensor Cover Label	710487
Horn, Protective Insert	10046042