

Specification

| | |
|--|--|
| Type: | Operating temperature range: |
| CEL-284/2: Calibrator to IEC 942 Class 1L, CEL-282: Calibrator to IEC 942 Class 2L, Both calibrators meet ANSI S1.40-1984. | CEL-284/2: +5 to +35°C ±0.3 dB, Both calibrators: -10 to +50°C ±0.5 dB. |
| Calibration reference condition: | Effect of humidity: |
| 20°C, 101.3 kPa, and 65%RH. | CEL-284/2: ±0.3 dB in the range 30 to 90%RH referred to 65%RH, in the absence of condensation, CEL-282: ±0.5 dB in the range 30 to 90%RH referred to 65%RH, in the absence of condensation. |
| Calibration level: (at reference conditions) | Battery: |
| CEL-284/2: 114.0 dB ±0.3 dB, CEL-282: 114.0 dB ±0.5 dB. | 1 x 9 V (PP3; IEC 6F22; IEC 6LR61). Alkaline manganese is recommended and gives a battery life better than 24 hours. |
| Calibration frequency: | Dimensions: (earlier versions) |
| 1 kHz ±5 Hz. | 45 x 68 x 125 mm (1.8 x 2.7 x 4.9 in). Weight: (including battery) 230 g (0.51 lb). |
| Stabilising time: | Dimensions: (later versions with 2/ serial no.) |
| 5 s. | 45 x 71 x 128 mm (1.8 x 2.8 x 5.0 in). Weight: (including battery) 250 g (0.55 lb). |
| Harmonic Distortion: | |
| Less than 0.5%. | |
| Output voltage: (CEL-284/2 only) | |
| 100 mV RMS ±1 mV at 1 kHz. | |

Manufacturers Servicing & Warranty Arrangements

In order to ensure its rigid conformity with the requirements of the specification, this instrument is thoroughly inspected and calibrated prior to dispatch from the factory. All technical information for an individual instrument is filed under the instrument serial number. Therefore, the serial number should be quoted in any correspondence concerning the instrument.

The manufacturers undertake to rectify any defect in the instrument that is directly attributable to faulty design or assembly, and which becomes apparent during the warranty period. In order to take advantage of this warranty, the instrument must be returned, carriage paid, to the manufacturer's factory or accredited agent, where necessary repairs will be carried out. Normally the warranty period runs for 12 months from the date of receipt of goods, with exceptions on certain specialised components supplied by other manufacturers which are warranted for shorter periods.

Some of the specialised components used in this instrument may be subject to longer guarantees by their actual manufacturers, and in all such cases, the benefit of these undertakings will be passed on to the user. However, CASELLA CEL's liability is limited to items of their own manufacture, and they do not accept liability for any loss resulting from the operation or interpretation of the results from this equipment.

A comprehensive Instrument Calibration Maintenance Agreement (ICMA) scheme is available to extend the initial warranty period of this instrument. At the end of the first warranty period, it is recommended that the equipment be returned to the Service and Re-calibration Department at Bedford, where it will be

inspected and entered into the ICMA scheme as required. The warranty will then be extended for the period stated on the individual schedule. Please contact your local CASELLA CEL agent for full details of this service.

In addition, CEL Instruments Ltd. has an UKAS accredited laboratory No. 0237 which is able to perform certain acoustic calibrations with traceability to U.K. National Standards, details on request.

In the event of a malfunction developing during the warranty period, the instrument should be carefully packed and returned either to CASELLA CEL's local agent, or in the case of domestic sales, to the CASELLA CEL Service Department at Bedford. Please include the following information:

Instrument Type(s), Serial Number(s) and Firmware version number(s),
Customer name and address,
Contact name and phone number,
Details of any PC and software involved, including version number(s),
Reason for returning the equipment with a detailed description of the fault,
List of any error messages that may have been displayed.

The necessary adjustments or repairs will be carried out, and the instrument returned as soon as possible.

After the warranty has expired (except on approved accounts) service work is undertaken against quotations, and all packing and transit costs are charged extra.

CEL-284/2 ACOUSTICAL CALIBRATOR CLASS 1L

CEL-282 ACOUSTICAL CALIBRATOR CLASS 2L

Instructions

060050
Issue: 4
August 1999

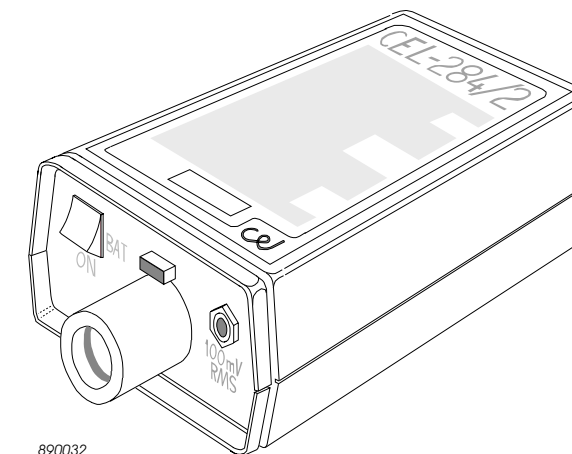

INTRODUCTION

The CEL-284/2 and CEL-282 Acoustical Calibrators are an accurate and easily used means of calibrating microphones and sound level meters in the laboratory and in field.

The CEL-284/2 has been designed to satisfy the requirements of IEC 942 Class 1L, while the CEL-282 satisfies the Class 2L standard. In addition, both instruments meet the requirements of ANSI S1.40-1984.

These calibrators are intended for use with industry standard "half-inch" microphones, and may also be used to calibrate smaller microphones by means of suitable Microphone Couplers. A CEL-4725 Coupler suitable for "quarter-inch" microphones is supplied with the calibrator.

Both calibrators produce a highly stable sine wave excitation, with less than 0.5% harmonic distortion, in an acoustic cavity. The transducers

used are pre-aged and matched to the driving circuits, so that the long term stability of the system is assured.

The nominal free field (equivalent) calibration level is 114.0 dB (101.3 kPa) at a frequency of 1 kHz and temperature of 20°C. Half-inch microphones can be calibrated directly, while smaller sizes such as CEL 9 mm mounted (on early CEL-272, D-1423D and CEL-281 Dosemeters) and quarter-inch can be calibrated when connected via a suitable microphone coupler.

In addition, the CEL-284/2 provides a 100 mV RMS signal at 1 kHz via a 3.5 mm socket so that vibration measuring systems may be calibrated.



CEL and DAWE instrumentation is designed, manufactured, and serviced by:
CASELLA CEL, Regent House, Wolseley, Kempston, Bedford, MK42 7JY, United Kingdom.
Phone: (44) 1234 844100 Fax: (44) 1234 841490, e-mail: celsales@casella.co.uk

17 Old Nashua Road #15, Amherst, NH 03031, U.S.A.
Phone: (1) 603 672 0031 Fax: (1) 603 672 8053 e-mail: cel_sales@compuserve.com

SCHEDULE OF PARTS

A complete “CEL-284/2 Acoustical Calibrator” consists of the following items.

| | | | |
|----------------|---------------------------|----------------|---------------------------|
| CEL-284/2 | Calibrator (Class 1L), | CEL-282 | Calibrator (Class 2L), |
| CEL-4725 | Microphone Coupler (¼”), | CEL-4725 | Microphone Coupler (¼”), |
| 016003 (1 off) | Battery, (IEC type 6F22), | 016003 (1 off) | Battery, (IEC type 6F22), |
| 060050 | Handbook. | 060050 | Handbook. |

PREPARATION FOR USE

Make the instrument ready for use by installing a single 9 V battery. Zinc carbon (IEC 6F22) and nickel cadmium (rechargeable) batteries are suitable.

However, for the most reliable operation with longest battery life, a manganese alkaline battery is recommended.

Check the battery condition by switching the instrument on, and ensuring that the indicator lamp is lit for only about one second. If the indicator remains lit or does not light at all, replace the battery.

The instrument is now ready for service. (If the calibrator is to be out of service for long periods, remove the battery.)

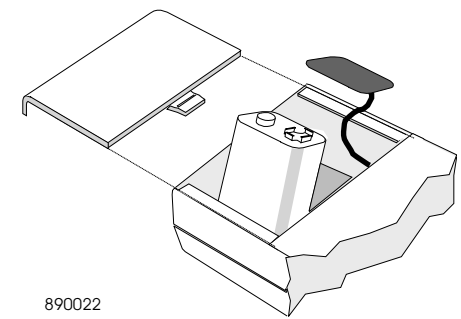

890022

Caution

Make sure the instrument is switched OFF while a battery is being connected.

The battery compartment is exposed by sliding open the cover on the rear of the instrument.

Fix the battery terminals firmly to the battery lead connectors and ensure correct polarity. Replace the cover after loading and clip it securely in place.

OPERATION
Field Accuracy Check (Acoustic Calibration)

Perform a field accuracy check (acoustic calibration) with the CEL-284/2 or CEL-282 immediately before and after measurements are made with a sound level meter or sound measuring system as follows.

A very small amount of silicone grease may be used to lubricate the seals; however, do not allow grease to enter the vent holes in the microphone.

Caution

Make sure the microphone, calibrator and coupler (when used) are correctly aligned, as microphone damage can be caused by the firm pressure required to overcome the resistance of the “O” ring seals in both calibrator and coupler.

1. With a quarter-inch microphone, first insert the microphone into the cavity of the CEL-4725 Coupler (supplied with the calibrator), ensuring that it makes contact with the shoulder in the cavity.
2. With a CEL 9 mm mounted microphone, first insert the microphone into the cavity of a CEL-6050 Coupler (supplied with the

measuring instrument), ensuring that it makes contact with the shoulder in the cavity.

3. Insert the coupler (complete with microphone) into the calibrator cavity, again making sure that it makes contact with the shoulder.

To aid removal, the coupler flange is designed NOT TO fit flush against the calibrator rim.

4. With a half-inch microphone, insert the microphone directly into the calibrator cavity, ensuring that it makes contact with the shoulder in the cavity.

5. Switch the measuring instrument ON.

6. Select a suitable measuring range and frequency weighting for the calibration; refer to the relevant handbook.

7. Switch the calibrator ON to obtain a nominal 114.0 dB at 1 kHz (at standard temperature and pressure - STP: 20°C:101.3 kPa:65%RH).

8. Wait 20 s for both calibrator and measuring instrument reading to stabilise.

The display should indicate the level shown for a particular microphone or instrument in the table. Refer to the graph for any correction that may be applied to this level.

9. If necessary, adjust the calibration control of the measuring instrument until it gives the indication required by the table and graph.

| Microphone Type | Nominal SLM Calibration Level dB | Microphone Correction Factor ¹ dB | | |
|-------------------------------|----------------------------------|--|--------------------|-------------------|
| ½" Types | | | | |
| CEL-186/2F | 114.0 | | +0.2 | |
| CEL-186/2RP | 113.8 | | NA | |
| CEL-186/3F | 114.0 | | +0.2 | |
| CEL-192/1F | 114.2 | | +0.4 | |
| CEL-192/2F | 114.0 | | +0.2 | |
| CEL-192/2R | 113.8 | | NA | |
| CEL-192/3F | 114.0 | | +0.2 | |
| CEL-250/MK 250 | 114.0 | | +0.2 | |
| CEL-292 | 113.7 | | -0.1 | |
| B & K 4133 | 113.8 | | 0 | |
| ¼" Types² | | | | |
| | Post 1/1/96 | Pre 1/1/96 | Post 1/1/96 | Pre 1/1/96 |
| On Preamp. | | | | |
| CEL-485 | 113.6 | | -0.2 | |
| CEL-230 | 113.6 | 114.0 | -0.2 | +0.2 |
| RFT MK 301 | 114.0 | 114.0 | +0.2 | +0.2 |
| On SLM | | | | |
| CEL-231/D-1405E | 113.6 | | -0.2 | |
| CEL-254/D-1422C | 113.6 | 114.0 | -0.2 | +0.2 |
| CEL-269/D-1421D | 113.6 | 114.0 | -0.2 | +0.2 |
| On Dosimeter | | | | |
| CEL-6685 | 113.6 | | -0.2 | |
| CEL-425 | 113.6 | | -0.2 | |
| CEL-272/D-1423D | 113.6 | | -0.2 | |
| CEL-281 | 113.6 | | -0.2 | |
| 9 mm Types³ | | | | Pre 1/1/96 |
| On dosimeter | | | | |
| CEL-272/D-1423D | | 114.0 | | +0.2 |
| CEL-281 | | 114.0 | | +0.2 |

¹Add this factor to the pressure level only when such a level is given on an appropriate calibration certificate.
²Use CEL-4725 Coupler.
³Use CEL-6050 Coupler.

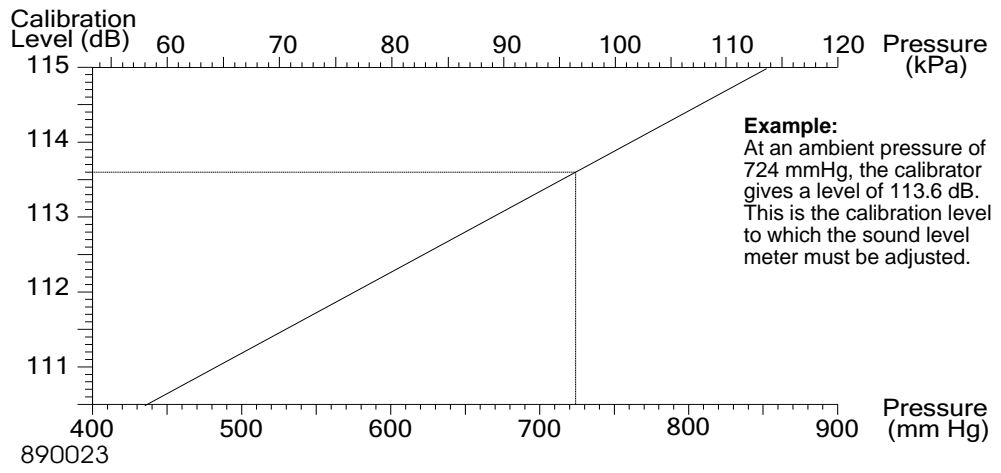

10. After use, switch the calibrator OFF, and remove it and any coupler from the microphone.

Variations in atmospheric pressure both at altitude and at sea level will also have an effect on the acoustic calibration level, and follow the curve shown in the graph. It is recommended that a barometer be used to measure air pressure during calibration, to determine whether the indicated calibration level needs to be corrected.

Accelerometer Calibration (CEL-284/2 only)

Caution

DO NOT attempt to perform simultaneous acoustic and electrical calibrations as the acoustic level changes when a plug is inserted into the 100 mV outlet.

Immediately before and after taking measurements, calibrate a vibration measurement system using the electrical method and employing the CEL-284/2 as follows.

1. Remove the accelerometer lead from the measurement system and replace it with a C5681/1 Cable that has a 3.5 mm sub-miniature jack-plug using ring as signal, and tip and sleeve as ground.
2. Insert the 3.5 mm sub-miniature plug at the free end into the socket on the calibrator.

3. Switch the vibration measurement system ON.
4. Select a suitable measuring range for the calibration, refer to the relevant handbook.
5. Wait for the measuring system to stabilise.
6. Switch the calibrator on to obtain 100 mV at 1 kHz and wait 5 s for it to stabilise.
7. Check that the measuring system indicates the level required by the relevant handbook.
8. If necessary, adjust the calibration or level control on the measuring system until it gives the correct indication.
9. Switch the calibrator off, and disconnect it after use.

CE Compliance

The CEL-282/4 and CEL-282 Acoustical Calibrators comply with the EMC Directive 89/336/EEC of the European Union. They have been tested according to the standard delivery schedule and comply with the following standards.

commercial, light industry and industrial environments.

EN 50081-1: 1992 & EN 50081-2: 1993 Generic emission standards for residential,

EN 50082-1: 1992 & EN 50082-2: 1995 Generic immunity standards (for both RF fields and electrostatic discharge) for residential, commercial, light industry and industrial environments.

| CEL and Dawe Equivalent Identities | | | | | | |
|------------------------------------|---------------------|---------------------|----------------------------|---------------------|-------------------------|-------------------------------|
| Instrument | Class 1L Calibrator | Class 2L Calibrator | Digital Sound Survey Meter | Digital Impulse SLM | Digital Integrating SLM | Personal Sound Exposure Meter |
| CEL Identity | CEL-284/2 | CEL-282 | CEL-231 | CEL-254 | CEL-269 | CEL-272 |
| Dawe Identity | D-1418D | D-1411E | D-1405E | D-1422C | D-1421D | D-1423D |